



**Hewlett Packard**  
Enterprise

# **HPE ProLiant DL380 Gen9 Server**

## User Guide

### Abstract

This document is for the person who installs, administers, and troubleshoots servers and storage systems. Hewlett Packard Enterprise assumes you are qualified in the servicing of computer equipment and trained in recognizing hazards in products with hazardous energy levels.

Part Number: 768830-006  
June 2016  
Edition: 6

© Copyright 2014, 2016 Hewlett Packard Enterprise Development LP

The information contained herein is subject to change without notice. The only warranties for Hewlett Packard Enterprise products and services are set forth in the express warranty statements accompanying such products and services. Nothing herein should be construed as constituting an additional warranty. Hewlett Packard Enterprise shall not be liable for technical or editorial errors or omissions contained herein.

Links to third-party websites take you outside the Hewlett Packard Enterprise website. Hewlett Packard Enterprise has no control over and is not responsible for information outside the Hewlett Packard Enterprise website.

Microsoft® and Windows® are either registered trademarks or trademarks of Microsoft Corporation in the United States and/or other countries.

Linux® is the registered trademark of Linus Torvalds in the U.S. and other countries.

Red Hat® is a registered trademark of Red Hat, Inc. in the United States and other countries.

Java is a registered trademark of Oracle and/or its affiliates.

SD and microSD are trademarks or registered trademarks of SD-3C in the United States, other countries or both.

VMware is a registered trademark or trademark of VMware, Inc. in the United States and/or other jurisdictions.

Intel® and Xeon® are trademarks of Intel Corporation in the U.S. and other countries.

# Contents

Component identification .....	7
Front panel components.....	7
Front panel LEDs and buttons.....	9
UID button functionality .....	10
Power fault LEDs.....	11
Access the optional HPE Systems Insight Display.....	11
Systems Insight Display LEDs .....	12
Systems Insight Display LED combinations .....	13
Rear panel components .....	14
Rear panel LEDs .....	14
Flex slot battery backup module LEDs and buttons .....	15
Non-hot-plug PCI riser board slot definitions.....	16
System board components.....	17
System maintenance switch .....	18
NMI functionality .....	18
DIMM slot locations .....	19
SAS and SATA device numbers .....	19
Hot-plug drive LED definitions.....	22
NVMe SSD components .....	23
Hot-plug fans .....	23
Operations .....	26
Powering up the server .....	26
Power down the server.....	26
Extend the server from the rack .....	26
Remove the server from the rack.....	27
Remove the access panel.....	27
Install the access panel.....	28
Access the product rear panel.....	28
Opening the cable management arm .....	28
Remove the fan cage .....	29
Remove the hot-plug fan .....	30
Remove the PCI riser cage .....	30
Install the PCI riser cage .....	31
Secure the full-length expansion board retainer.....	32
Remove the air baffle .....	32
Install the air baffle .....	33
Setup .....	35
Optional services.....	35
Optimum environment.....	35
Space and airflow requirements .....	35
Temperature requirements .....	36
Power requirements .....	36
Electrical grounding requirements .....	37
Connecting a DC power cable to a DC power source .....	37
Rack warnings.....	38
Identifying the contents of the server shipping carton .....	38
Installing hardware options.....	39
Installing the server into the rack.....	39
Installing the operating system.....	40
Powering on and selecting boot options in UEFI Boot Mode .....	41
Powering on and selecting boot options.....	41
Registering the server .....	42

Hardware options installation.....	43
Hewlett Packard Enterprise product QuickSpecs.....	43
Introduction.....	43
Hot-plug drive guidelines.....	43
Drive options.....	43
Removing the hard drive blank.....	44
Installing a hot-plug SAS or SATA drive.....	44
Removing a hot-plug SAS or SATA hard drive.....	45
Installing the NVMe drives.....	45
Express Bay drive cage.....	46
Installing the airflow labels.....	47
Installing the Express Bay drive cage.....	48
Redundant hot-plug power supply option.....	55
High-performance fan option.....	56
Processor and fan option.....	58
Memory options.....	63
Memory-processor compatibility information.....	63
SmartMemory.....	65
Memory subsystem architecture.....	65
DIMM ranks.....	66
DIMM identification.....	66
Memory configurations.....	67
General DIMM slot population guidelines.....	68
Identifying the processor type.....	69
Installing a DIMM.....	69
Universal media bay option.....	70
2-slot PCI riser cage option.....	73
3-slot PCI riser cage option.....	75
GPU enablement kit.....	77
Eight-bay SFF front drive cage option for bay 1.....	82
Eight-bay SFF front drive cage option for bay 2.....	86
Three-bay LFF rear drive cage option.....	89
Two-bay SFF front drive cage option.....	94
Two-bay SFF rear drive cage option.....	98
Systems Insight Display power switch module option.....	105
Location Discovery Services rear option.....	107
Smart Storage Battery.....	109
FlexibleLOM option.....	110
Expansion board options.....	112
Removing an expansion slot blank.....	112
Installing an expansion board.....	113
HPE H240 Smart HBA/P440, P840 Flexible Smart Array Controller.....	114
HPE P440ar/P840ar Flexible Smart Array Controller.....	116
12G SAS Expander Card.....	118
Rear serial port option.....	125
M.2 SSD Enablement Board option.....	126
Installing an SSD module on the M.2 SSD Enablement Board.....	126
Installing an M.2 SSD enablement board.....	127
Dual 8Gb microSD Enterprise Midline USB device.....	129
750 W Flex Slot Hot Plug Battery Backup Module.....	129
Flex slot battery backup module configuration load support.....	129
Installing the FSBBU.....	130
HP Trusted Platform Module option.....	131
Installing the Trusted Platform Module board.....	132
Retaining the recovery key/password.....	133
Enabling the Trusted Platform Module.....	134
Cabling.....	135
Cabling overview.....	135
Two-bay SFF drive cage option cabling.....	135
Three-bay LFF rear drive cage cabling.....	139

Eight-bay SFF front drive cage cabling .....	141
Express Bay Enablement Option cabling options .....	146
8SFF drive cage installed in bay 1 .....	147
8SFF drive cage installed in bay 1 and 2SFF drives in the rear of the server .....	148
Drive bay 1 is empty .....	149
8SFF drive cage installed in bay 1 and 2 SFF drives in the front of the server .....	150
Host Bus Adapter and Controller cabling .....	150
HPE H240 Smart Host Bus Adapter/Smart Array P440 Controller cabling .....	151
HPE Smart Array P840 Controller cabling.....	154
HPE Smart Array P440ar Controller cabling .....	155
HPE Smart Array P840ar Controller cabling .....	159
Universal media bay cabling .....	164
150W PCIe power cable option.....	167
M.2 SSD Enablement Board option cabling .....	167
<b>Software and configuration utilities .....</b>	<b>169</b>
Server mode.....	169
Product QuickSpecs.....	169
HPE iLO .....	169
Active Health System .....	170
iLO RESTful API support.....	170
Integrated Management Log .....	171
HPE Insight Remote Support .....	171
Intelligent Provisioning .....	172
HPE Insight Diagnostics.....	172
HPE Insight Diagnostics survey functionality .....	172
Erase Utility .....	173
Scripting Toolkit for Windows and Linux .....	173
Service Pack for ProLiant.....	173
HP Smart Update Manager .....	174
HPE UEFI System Utilities .....	174
Using UEFI System Utilities.....	174
Flexible boot control .....	175
Restoring and customizing configuration settings .....	175
Secure Boot configuration .....	175
Embedded UEFI shell.....	176
Embedded Diagnostics option.....	176
iLO RESTful API support for UEFI .....	176
Re-entering the server serial number and product ID .....	176
Utilities and features.....	177
HPE Smart Storage Administrator.....	177
Automatic Server Recovery.....	177
USB support .....	177
Redundant ROM support.....	178
Keeping the system current.....	179
Access to Hewlett Packard Enterprise Support Materials .....	179
Updating firmware or System ROM.....	179
Drivers .....	180
Software and firmware.....	180
Operating System Version Support.....	181
Version control.....	181
Operating systems and virtualization software support for ProLiant servers.....	181
HPE Technology Service Portfolio .....	181
Change control and proactive notification .....	182
<b>Troubleshooting .....</b>	<b>183</b>
Troubleshooting resources.....	183
<b>Battery replacement.....</b>	<b>184</b>
<b>Warranty and regulatory information.....</b>	<b>185</b>
Warranty information .....	185

Regulatory information .....	185
Safety and regulatory compliance .....	185
Belarus Kazakhstan Russia marking .....	185
Turkey RoHS material content declaration .....	186
Ukraine RoHS material content declaration .....	186
Specifications .....	187
Environmental specifications .....	187
Mechanical specifications .....	187
Power supply specifications .....	188
HPE 500W Flex Slot Platinum Hot-plug Power Supply .....	189
HPE 800W Flex Slot Platinum Hot-plug Power Supply .....	189
HPE 800W Flex Slot Titanium Plus Hot-plug Power Supply .....	190
HPE 800W Flex Slot Universal Hot-plug Power Supply .....	190
HPE 800W Flex Slot -48VDC Hot-plug Power Supply .....	191
HPE 1400W Flex Slot Platinum Plus Hot-plug Power Supply .....	192
HPE 750W Flex Slot Hot-plug Battery Backup Module .....	192
Hot-plug power supply calculations .....	192
Support and other resources .....	193
Accessing Hewlett Packard Enterprise Support .....	193
Information to collect .....	193
Accessing updates .....	193
Websites .....	193
Customer Self Repair .....	194
Remote support .....	201
Acronyms and abbreviations .....	202
Documentation feedback .....	206
Index .....	207

# Component identification

## Front panel components

- SFF model (8-drive)

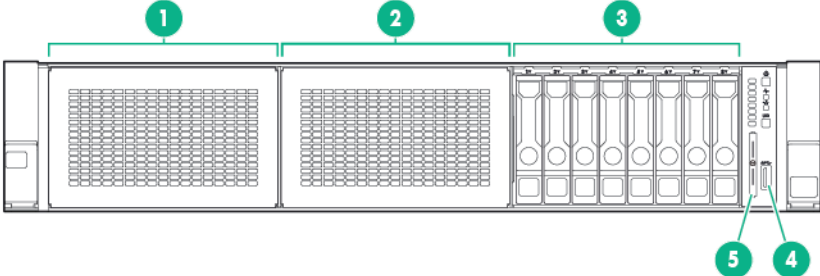

Item	Description
1	Bay 1 (optional drives or universal media bay)
2	Bay 2 (optional drives)
3	Fixed drive bays
4	Front USB 3.0 connector
5	Serial label pull tab

- SFF model (24-drive)



Item	Description
1	Bay 1
2	Bay 2
3	Bay 3, fixed drive bay
4	Front USB 3.0 connector
5	Serial label pull tab

- LFF model (12-drive)

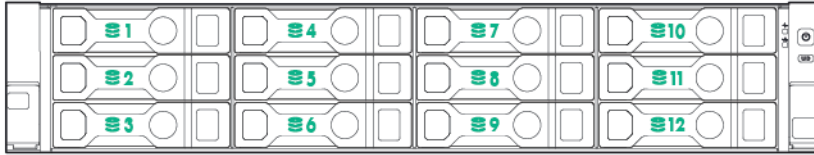

Item	Description
------	-------------

1-12	Drive bays
------	------------

- LFF model (4-drive)

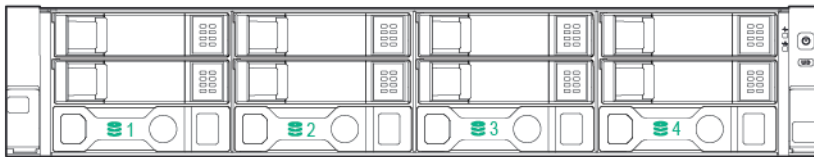

Item	Description
------	-------------

1-4	Drive bays
-----	------------



# Front panel LEDs and buttons

- SFF front panel LEDs and button

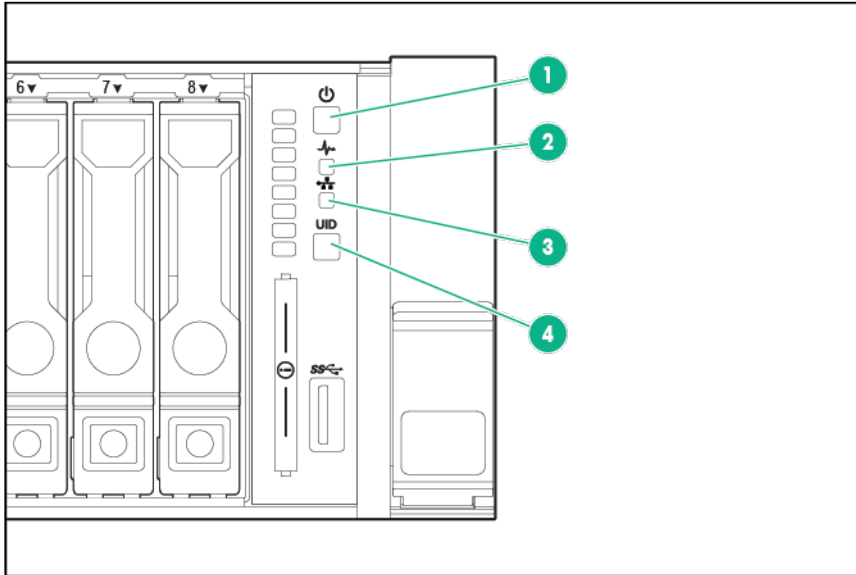

Item	Description	Status
1	Power On/Standby button and system power LED*	Solid green = System on Flashing green (1 Hz/cycle per sec) = Performing power on sequence Solid amber = System in standby Off = No power present**
2	Health LED*	Solid green = Normal Flashing green (1 Hz/cycle per sec) = iLO is rebooting Flashing amber = System degraded Flashing red (1 Hz/cycle per sec) = System critical†
3	NIC status LED*	Solid green = Link to network Flashing green (1 Hz/cycle per sec) = Network active Off = No network activity
4	UID button/LED*	Solid blue = Activated Flashing blue: <ul style="list-style-type: none"> <li>• 1 Hz/cycle per sec = Remote management or firmware upgrade in progress</li> <li>• 4 Hz/cycle per sec = iLO manual reboot sequence initiated</li> <li>• 8 Hz/cycle per sec = iLO manual reboot sequence in progress</li> </ul> Off = Deactivated

\*When all four LEDs described in this table flash simultaneously, a power fault has occurred. For more information, see "Power fault LEDs (on page 11)."

\*\*Facility power is not present, power cord is not attached, no power supplies are installed, power supply failure has occurred, or the power button cable is disconnected.

†If the health LED indicates a degraded or critical state, review the system IML or use iLO to review the system health status.

- LFF LEDs and button

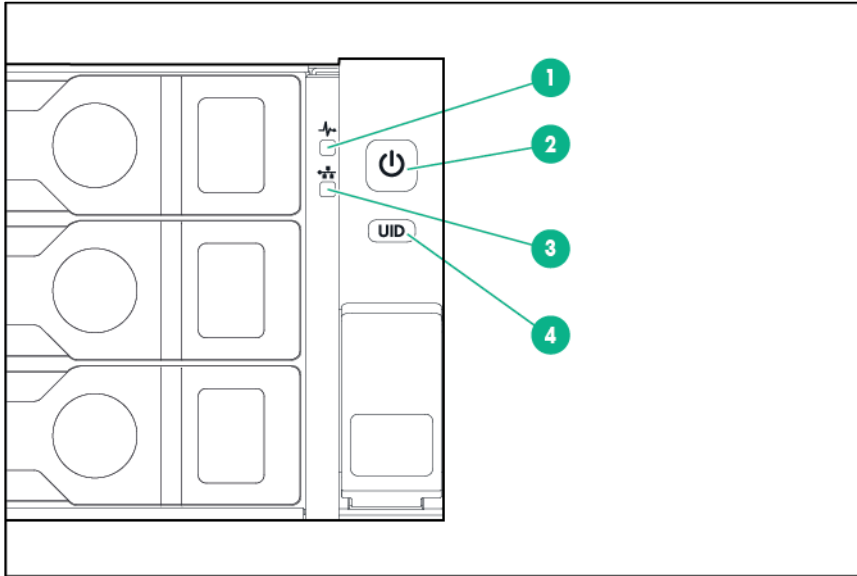

Item	Description	Status
1	Health LED*	Solid green = Normal Flashing green (1 Hz/cycle per sec) = iLO is rebooting Flashing amber = System degraded Flashing red (1 Hz/cycle per sec) = System critical**
2	Power On/Standby button and system power LED*	Solid green = System on Flashing green (1 Hz/cycle per sec) = Performing power on sequence Solid amber = System in standby Off = No power present†
3	NIC status LED*	Solid green = Link to network Flashing green (1 Hz/cycle per sec) = Network active Off = No network activity
4	UID button/LED*	Solid blue = Activated Flashing blue: <ul style="list-style-type: none"> <li>• 1 Hz/cycle per sec = Remote management or firmware upgrade in progress</li> <li>• 4 Hz/cycle per sec = iLO manual reboot sequence initiated</li> <li>• 8 Hz/cycle per sec = iLO manual reboot sequence in progress</li> </ul> Off = Deactivated

\*When all four LEDs described in this table flash simultaneously, a power fault has occurred. For more information, see "Power fault LEDs (on page 11)."

\*\*If the health LED indicates a degraded or critical state, review the system IML or use iLO to review the system health status.

†Facility power is not present, power cord is not attached, no power supplies are installed, power supply failure has occurred, or the power button cable is disconnected.

## UID button functionality

The UID button can be used to display the HPE ProLiant Pre-boot Health Summary when the server will not power on. For more information, see the *HPE iLO 4 User Guide* on the Hewlett Packard Enterprise website (<http://www.hpe.com/info/ilo/docs>).

# Power fault LEDs

The following table provides a list of power fault LEDs, and the subsystems that are affected. Not all power faults are used by all servers.

Subsystem	LED behavior
System board	1 flash
Processor	2 flashes
Memory	3 flashes
Riser board PCIe slots	4 flashes
FlexibleLOM	5 flashes
Removable HPE Flexible Smart Array controller/Smart SAS HBA controller	6 flashes
System board PCIe slots	7 flashes
Power backplane or storage backplane	8 flashes
Power supply	9 flashes

# Access the optional HPE Systems Insight Display

To access a pop-out HPE Systems Insight Display on models with this option installed:

1. Press and release the panel.
2. After the display fully ejects, rotate the display to view the LEDs.

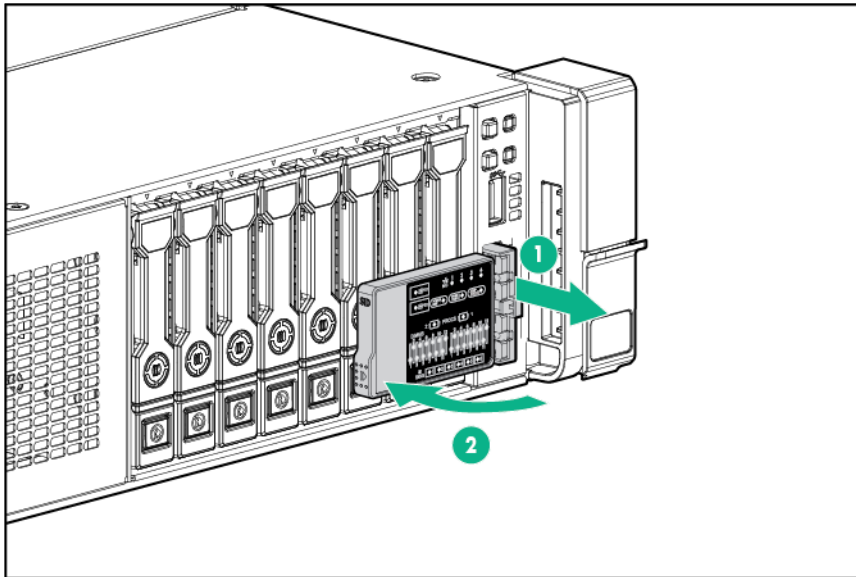

# Systems Insight Display LEDs

The Systems Insight Display LEDs represent the system board layout. The display enables diagnosis with the access panel installed.

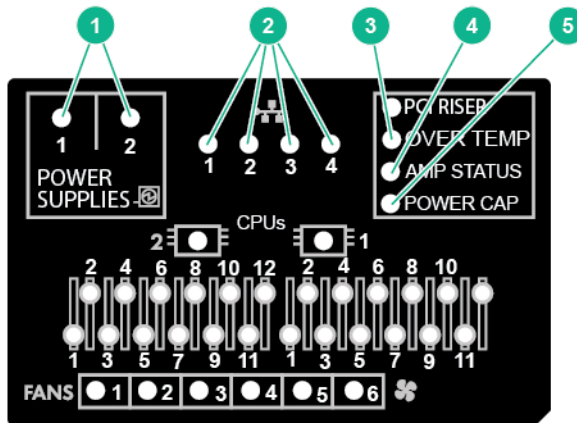

Item	Description	Status
1	Power supplies	Off = Normal Solid amber = Power subsystem degraded, power supply failure, or input power lost.
2	NIC link/activity	Off = No link to network. If the power is off, view the rear panel RJ-45 LEDs for status (" <a href="#">Rear panel LEDs</a> " on page 14). Flashing green = Network link and activity Solid green = Network link
3	Over temp	Off = Normal Solid amber = High system temperature detected
4	AMP status	Off = AMP modes disabled Solid green = AMP mode enabled Solid amber = Failover Flashing amber = Invalid configuration
5	Power cap	Off = System is in standby, or no cap is set. Solid green = Power cap applied
—	All other LEDs	Off = Normal Amber = Failure For more information on the activation of these LEDs, see "Systems Insight Display LED combinations (on page 13)."

# Systems Insight Display LED combinations

When the health LED on the front panel illuminates either amber or red, the server is experiencing a health event. Combinations of illuminated Systems Insight Display LEDs, the system power LED, and the health LED indicate system status.

Systems Insight Display LED and color	Health LED	System power LED	Status
Processor (amber)	Red	Amber	One or more of the following conditions may exist: <ul style="list-style-type: none"> <li>Processor in socket X has failed.</li> <li>Processor X is not installed in the socket.</li> <li>Processor X is unsupported.</li> <li>ROM detects a failed processor during POST.</li> </ul>
Processor (amber)	Amber	Green	Processor in socket X is in a pre-failure condition.
DIMM (amber)	Red	Green	One or more DIMMs have failed.
DIMM (amber)	Amber	Green	DIMM in slot X is in a pre-failure condition.
Over temp (amber)	Amber	Green	The Health Driver has detected a cautionary temperature level.
Over temp (amber)	Red	Amber	The server has detected a hardware critical temperature level.
PCI riser (amber)	Red	Green	The PCI riser cage is not seated properly.
Fan (amber)	Amber	Green	One fan has failed or has been removed.
Fan (amber)	Red	Green	Two or more fans have failed or been removed.
Power supply (amber)	Red	Amber	One or more of the following conditions may exist: <ul style="list-style-type: none"> <li>Only one power supply is installed and that power supply is in standby.</li> <li>Power supply fault</li> <li>System board fault</li> </ul>
Power supply (amber)	Amber	Green	One or more of the following conditions may exist: <ul style="list-style-type: none"> <li>Redundant power supply is installed and only one power supply is functional.</li> <li>AC power cord is not plugged into redundant power supply.</li> <li>Redundant power supply fault</li> <li>Power supply mismatch at POST or power supply mismatch through hot-plug addition</li> </ul>
Power cap (off)	—	Amber	Standby
Power cap (green)	—	Flashing green	Waiting for power
Power cap (green)	—	Green	Power is available.
Power cap (flashing amber)	—	Amber	Power is not available.



**IMPORTANT:** If more than one DIMM slot LED is illuminated, further troubleshooting is required. Test each bank of DIMMs by removing all other DIMMs. Isolate the failed DIMM by replacing each DIMM in a bank with a known working DIMM.

# Rear panel components

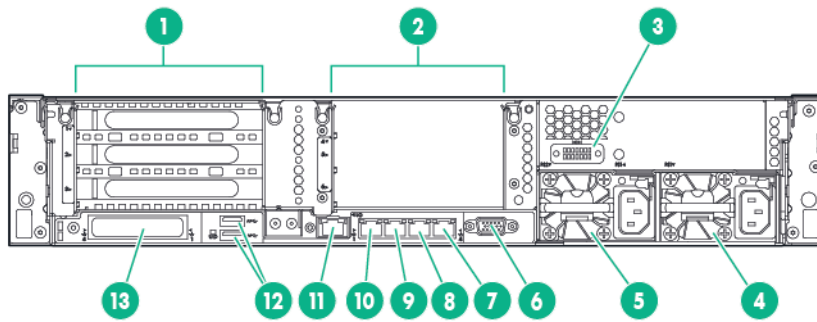

Item	Description
1	PCIe slots 1–3 (top to bottom)
2	Optional PCIe slots 4–6 (top to bottom)*
3	Optional serial port
4	Power supply 1 (PS1)
5	Power supply 2 (PS2)
6	Video connector
7	1Gb RJ-45 port 4
8	1Gb RJ-45 port 3
9	1Gb RJ-45 port 2
10	1Gb RJ-45 port 1
11	iLO connector
12	USB 3.0 connectors
13	FlexibleLOM option

\*Requires second processor

# Rear panel LEDs

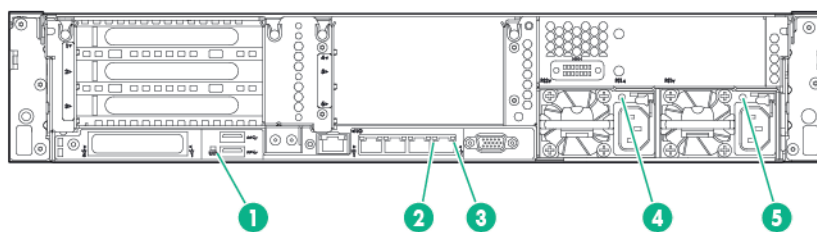

Item	Description	Status
1	UID LED	Off = Deactivated Solid blue = Activated Flashing blue = System being managed remotely
2	NIC link LED	Off = No network link Green = Network link
3	NIC activity LED	Off = No network activity

Item	Description	Status
		Solid green = Link to network Flashing green = Network activity
4	Power supply 2 LED	Off = System is off or power supply has failed. Solid green = Normal
5	Power supply 1 LED	Off = System is off or power supply has failed. Solid green = Normal

## Flex slot battery backup module LEDs and buttons

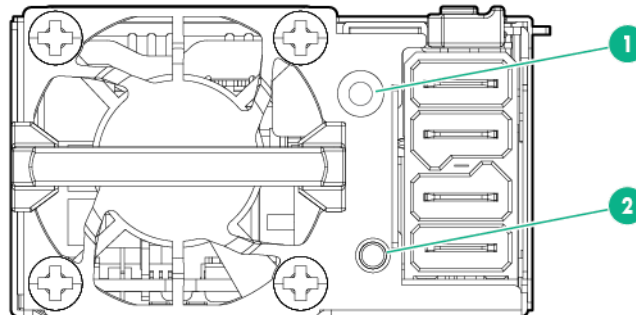

Item	Description
1	FSBBU module LED
2	Battery check button

When the battery check button is pressed, the LED indicates the state of the battery. The number of times that the LED flashes indicates the state of charge.

# of LED flashes	State of charge (%)
0	< 5
1	<= 30
2	31 – 69
3	>= 70

The state of the LED indicates the FSBBU operating mode.

LED	Mode/State
Off	<ul style="list-style-type: none"> <li>Ship/storage mode</li> <li>Cycle power operating</li> </ul>
Flashing amber	<ul style="list-style-type: none"> <li>Battery diagnostic</li> <li>Active mode</li> </ul>
Solid amber	Online mode and charger is ON
Flashing green	Discharge mode <ul style="list-style-type: none"> <li>RSOC—70-100% frequency=0.5Hz; duty=0.5</li> <li>RSOC—31-69% frequency=1Hz; duty=0.5</li> <li>RSOC—0-30% frequency=1.5Hz; duty=0.5</li> </ul>
Solid green	<ul style="list-style-type: none"> <li>Online mode and charger is OFF</li> <li>Battery is fully charged</li> </ul>

LED	Mode/State
Flashing red	Auxiliary path A/B protection
Solid red	FSBBU fault or other protections

For more information about the FSBBU module, see "750 W Flex Slot Hot Plug Battery Backup Module (on page 129)."

## Non-hot-plug PCI riser board slot definitions

- Primary riser cage connector, connected to processor 1 or the Southbridge

	PCIe 3-slot riser cage*	Optional PCIe 2-slot x16 riser cage
1 - FL/FH	PCIe3 x16 (8,4,2,1)	—
2 - HL/FH	PCIe3 x16 (8,4,2,1)	PCIe3 x16 (16,8,4,2,1)
3 - HL/FH	PCIe3 x8 (8,4,2,1)	PCIe3 x8 (8,4,2,1)

- Secondary riser cage connector, connected to processor 2 (processor 2 must be installed)

	PCIe 3-slot riser cage*
4 - FL/FH	PCIe3 x16 (16,8,4,2,1)
5 - HL/FH	PCIe3 x16 (16,8,4,2,1)
6 - HL/FH	PCIe3 x8 (8,4,2,1)

\*The server ships with one PCIe3 riser cage installed in the primary riser cage connector.

Notes:

- "Primary" denotes the riser cage is installed in the primary riser connector.
- "Secondary" denotes the riser cage is installed in the secondary riser connector.
- Installing the riser cages listed in the table above in either the primary or secondary riser connectors determines the form factor of the PCI expansion boards supported by those riser cages.
- FL/FH denotes full-length, full-height. HL/FH denotes half-length, full-height.

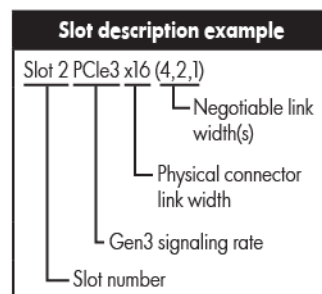



# System board components

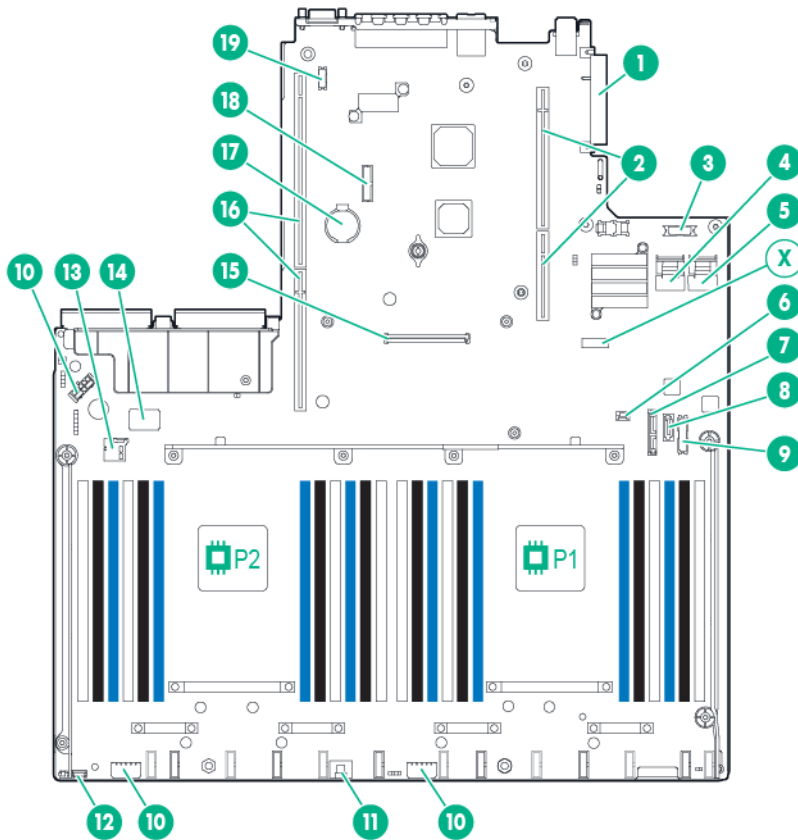

Item	Description
1	FlexibleLOM connector
2	Primary (processor 1) PCI riser connector
3	Optical front VGA/USB 2.0 connector
4	x4 SATA port 1
5	x4 SATA port 2
6	Backplane presence detect connector
7	Optical/SATA port 5
8	SATA port 4
9	Front power/USB 3.0 connector
10	Drive backplane power connector
11	HPE Smart Storage Battery connector
12	Optional Location Discovery Services connector
13	Micro SD card slot
14	Dual internal USB 3.0 connector
15	Smart Array/HBA connector
16	Secondary processor (processor 2) PCI riser connector
17	System battery
18	TPM connector
19	Optional serial port connector
X	System maintenance switch

# System maintenance switch

Position	Default	Function
S1	Off	Off = iLO security is enabled. On = iLO security is disabled.
S2	Off	Off = System configuration can be changed. On = System configuration is locked.
S3	Off	Reserved
S4	Off	Reserved
S5	Off	Off = Power-on password is enabled. On = Power-on password is disabled.
S6	Off	Off = No function On = ROM reads system configuration as invalid.
S7	Off	Off = Set default boot mode to UEFI. On = Set default boot mode to legacy.
S8	—	Reserved
S9	—	Reserved
S10	—	Reserved
S11	—	Reserved
S12	—	Reserved

To access the redundant ROM, set S1, S5, and S6 to On.

When system maintenance switch S6 is set to the On position, the system is prepared to erase all system configuration settings from both CMOS and NVRAM.



**IMPORTANT:** Before using the S7 switch to change to Legacy BIOS Boot Mode, be sure the HPE Dynamic Smart Array B140i Controller is disabled. Do not use the B140i controller when the server is in Legacy BIOS Boot Mode.

## NMI functionality

An NMI crash dump enables administrators to create crash dump files when a system is hung and not responding to traditional debug mechanisms.

Crash dump log analysis is an essential part of diagnosing reliability problems, such as hangs in operating systems, device drivers, and applications. Many crashes freeze a system, and the only available action for administrators is to cycle the system power. Resetting the system erases any information that could support problem analysis, but the NMI feature preserves that information by performing a memory dump before a hard reset.

To force the OS to invoke the NMI handler and generate a crash dump log, the administrator can use the iLO Virtual NMI feature.

For more information, see the Hewlett Packard Enterprise website (<http://www.hpe.com/support/NMI-CrashDump>).

# DIMM slot locations

DIMM slots are numbered sequentially (1 through 12) for each processor. The supported AMP modes use the letter assignments for population guidelines.

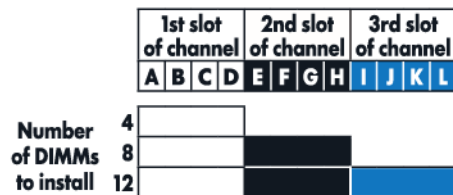
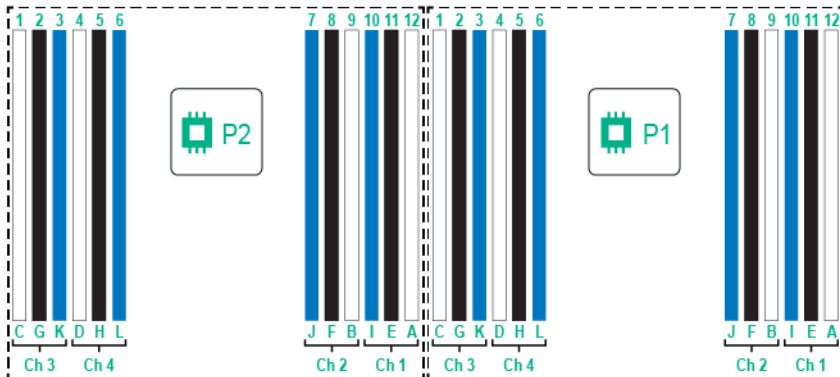

# SAS and SATA device numbers

- 8SFF device bay numbering

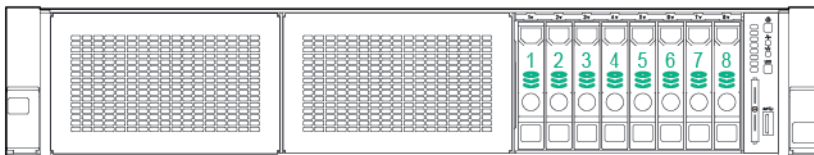

- Optional 16SFF device bay numbering

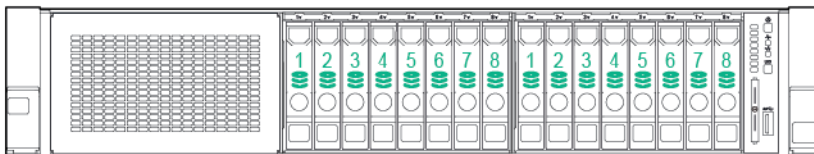

- Optional 16SFF device bay numbering with SAS expander solution used

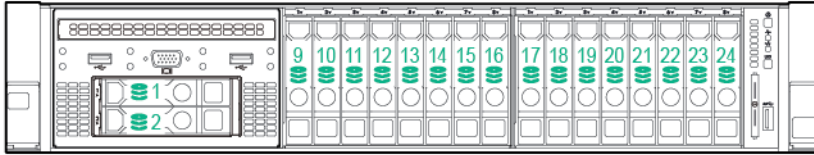

- Optional 24SFF device bay numbering

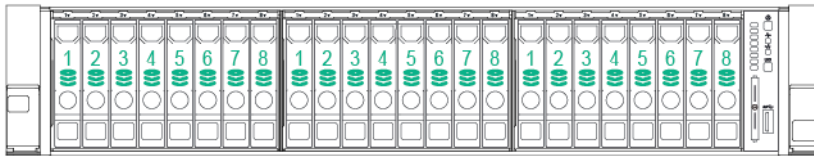

- Optional 24SFF device bay numbering with SAS expander solution used

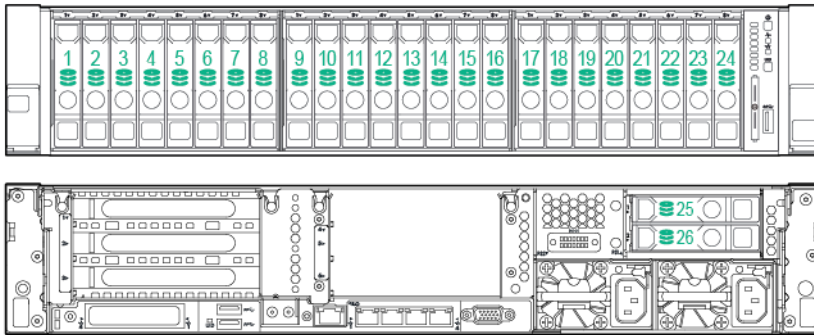

- 6SFF Express Bay Enablement Option device numbering with 8SFF drive cage installed in bay 1

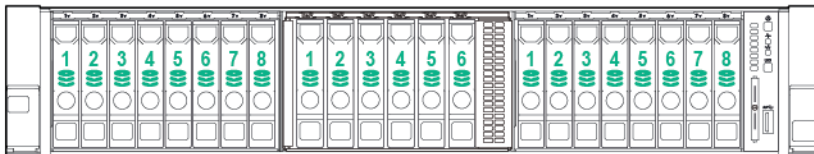

- 6SFF Express Bay Enablement Option device numbering with 2SFF drive cage installed in universal media bay 1

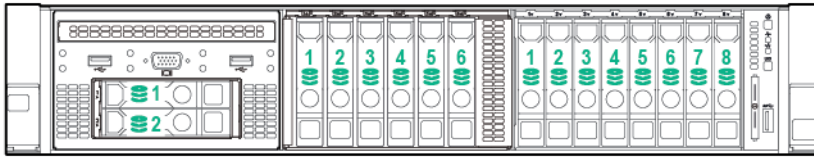

- 6SFF Express Bay Enablement Option device numbering with 2SFF drives installed at the rear of the server

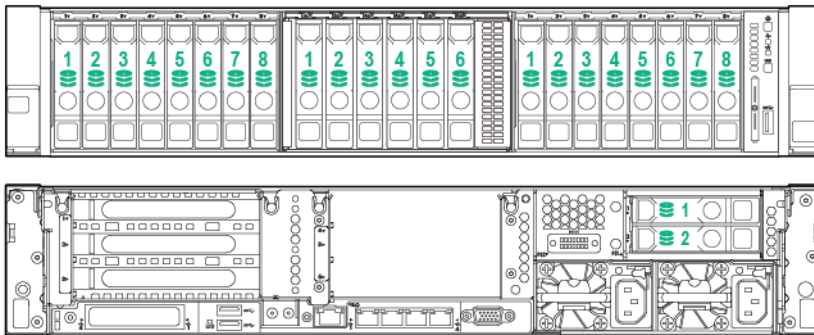

- 12LFF device bay numbering

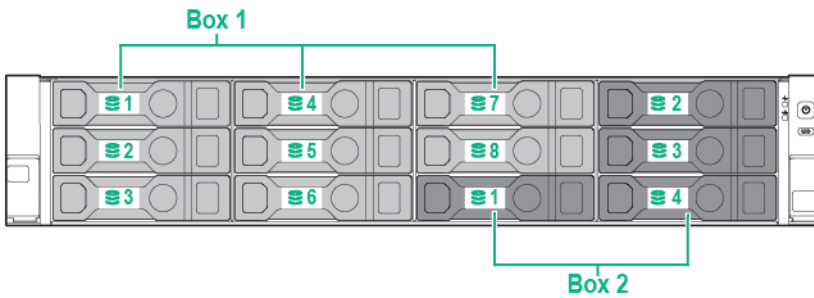

- 12LFF device bay numbering with 2-bay rear SAS expander solution used

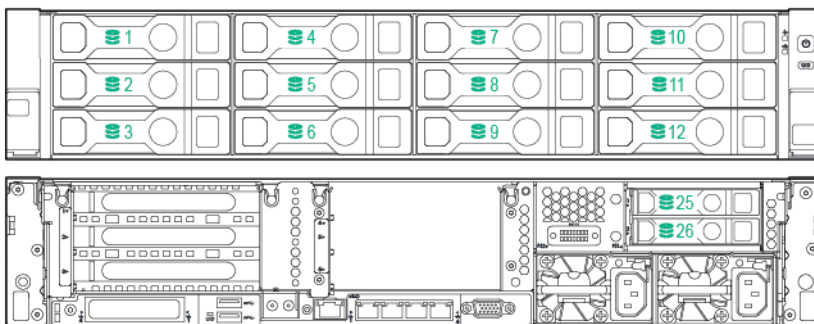

- 12LFF device bay numbering with 3-bay rear SAS expander solution used

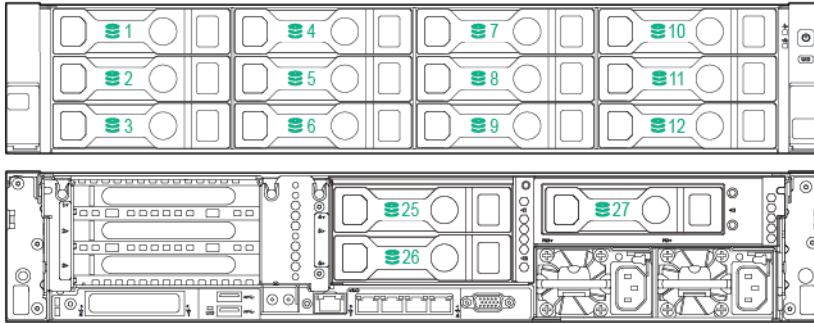

- 4LFF device bay numbering

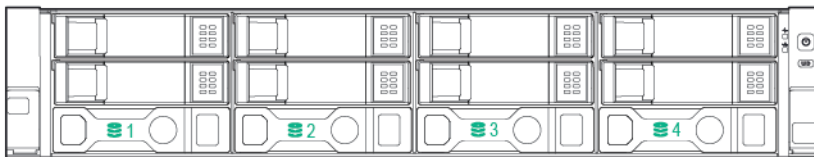

## Hot-plug drive LED definitions

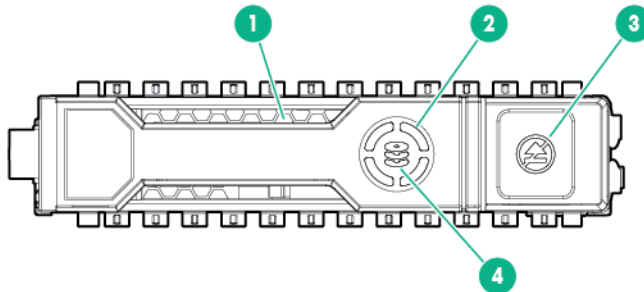

Item	LED	Status	Definition
1	Locate	Solid blue	The drive is being identified by a host application.
		Flashing blue	The drive carrier firmware is being updated or requires an update.
2	Activity ring	Rotating green	Drive activity
		Off	No drive activity
3	Do not remove	Solid white	Do not remove the drive. Removing the drive causes one or more of the logical drives to fail.
		Off	Removing the drive does not cause a logical drive to fail.
4	Drive status	Solid green	The drive is a member of one or more logical drives.

Item	LED	Status	Definition
		Flashing green	The drive is rebuilding or performing a RAID migration, strip size migration, capacity expansion, or logical drive extension, or is erasing.
		Flashing amber/green	The drive is a member of one or more logical drives and predicts the drive will fail.
		Flashing amber	The drive is not configured and predicts the drive will fail.
		Solid amber	The drive has failed.
		Off	The drive is not configured by a RAID controller.

## NVMe SSD components

The NVMe SSD is a PCIe bus device. A device attached to a PCIe bus cannot be removed without allowing the device and bus to complete and cease the signal/traffic flow.

- △ **CAUTION:** Do not remove an NVMe SSD from the drive bay while the Do Not Remove button LED is flashing. The Do Not Remove button LED flashes to indicate the device is still in use. Removal of the NVMe SSD before the device has completed and ceased signal/traffic flow can cause loss of data.

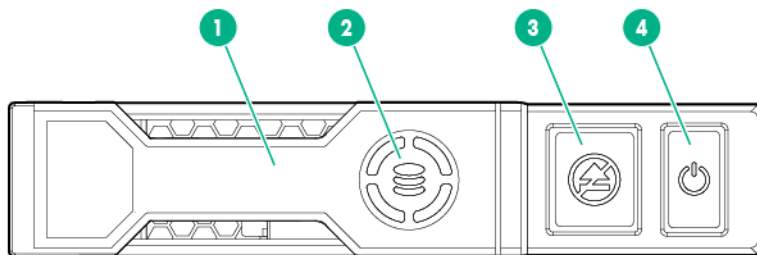

Item	Description
1	Release lever
2	Activity ring
3	Do Not Remove button
4	Power button

## Hot-plug fans

- △ **CAUTION:** To avoid damage to server components, fan blanks must be installed in fan bays 1 and 2 in a single-processor configuration.

- △ **CAUTION:** To avoid damage to the equipment, do not operate the server for extended periods of time if the server does not have the optimal number of fans installed. Although the server might boot, Hewlett Packard Enterprise does not recommend operating the server without the required fans installed and operating.

Valid fan configurations are listed in the following table.

Configuration	Fan bay 1	Fan bay 2	Fan bay 3	Fan bay 4	Fan bay 5	Fan bay 6
1 processor	Fan blank	Fan blank	Fan	Fan	Fan	Fan
1 processor, 24 SFF or 12 LFF configuration with high-performance fans	Fan	Fan	Fan	Fan	Fan	Fan
2 processors	Fan	Fan	Fan	Fan	Fan	Fan

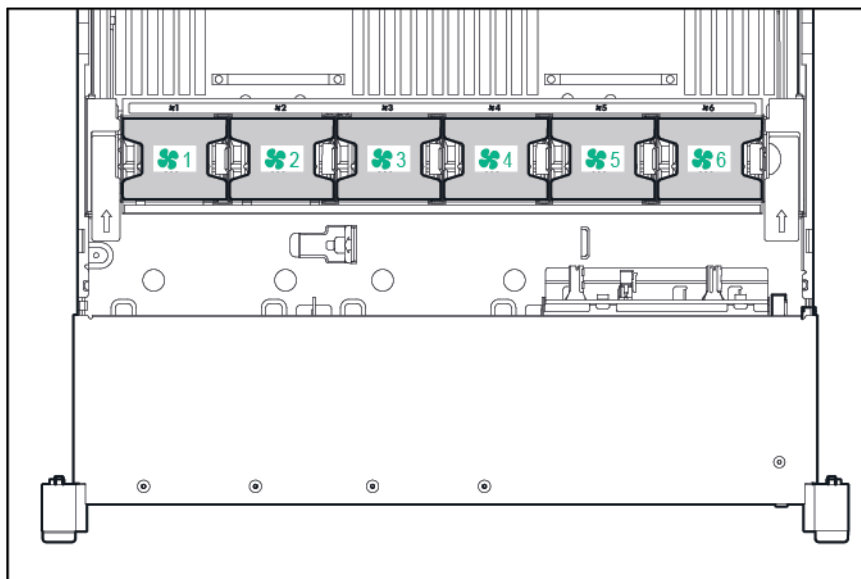

For a single-processor configuration, excluding 24-SFF and 12-LFF configurations, four fans and two blanks are required in specific fan bays for redundancy. A fan failure or missing fan causes a loss of redundancy. A second fan failure or missing fan causes an orderly shutdown of the server.

For a dual-processor configuration or single-processor 24-SFF or 12-LFF configurations, six fans are required for redundancy. A fan failure or missing fan causes a loss of redundancy. A second fan failure or missing fan causes an orderly shutdown of the server.

The high-performance fans are used for 24-SFF and 12-LFF drive configurations and might be necessary for the following installations:

- Optional GPU riser installations
- ASHRAE compliant configurations

For more information, see the Hewlett Packard Enterprise website (<http://www.hpe.com/servers/ASHRAE>).

The server supports variable fan speeds. The fans operate at minimum speed until a temperature change requires a fan speed increase to cool the server. The server shuts down during the following temperature-related scenarios:

- At POST and in the OS, iLO performs an orderly shutdown if a cautionary temperature level is detected. If the server hardware detects a critical temperature level before an orderly shutdown occurs, the server performs an immediate shutdown.
- When the Thermal Shutdown feature is disabled in the BIOS/Platform Configuration (RBSU), iLO does not perform an orderly shutdown when a cautionary temperature level is detected. Disabling this feature does not disable the server hardware from performing an immediate shutdown when a critical temperature level is detected.





---

**CAUTION:** A thermal event can damage server components when the Thermal Shutdown feature is disabled in the BIOS/Platform Configuration (RBSU).

---

# Operations

## Powering up the server

To power up the server, press the Power On/Standby button.

## Power down the server

Before powering down the server for any upgrade or maintenance procedures, perform a backup of critical server data and programs.



---

**IMPORTANT:** When the server is in standby mode, auxiliary power is still being provided to the system.

---

To power down the server, use one of the following methods:

- Press and release the Power On/Standby button.  
This method initiates a controlled shutdown of applications and the OS before the server enters standby mode.
- Press and hold the Power On/Standby button for more than 4 seconds to force the server to enter standby mode.  
This method forces the server to enter standby mode without properly exiting applications and the OS. If an application stops responding, you can use this method to force a shutdown.
- Use a virtual power button selection through iLO.  
This method initiates a controlled remote shutdown of applications and the OS before the server enters standby mode.

Before proceeding, verify the server is in standby mode by observing that the system power LED is amber.

## Extend the server from the rack



---

**WARNING:** To reduce the risk of personal injury or equipment damage, be sure that the rack is adequately stabilized before extending a component from the rack.

---

1. Pull down the quick release levers on each side of the server.

2. Extend the server from the rack.

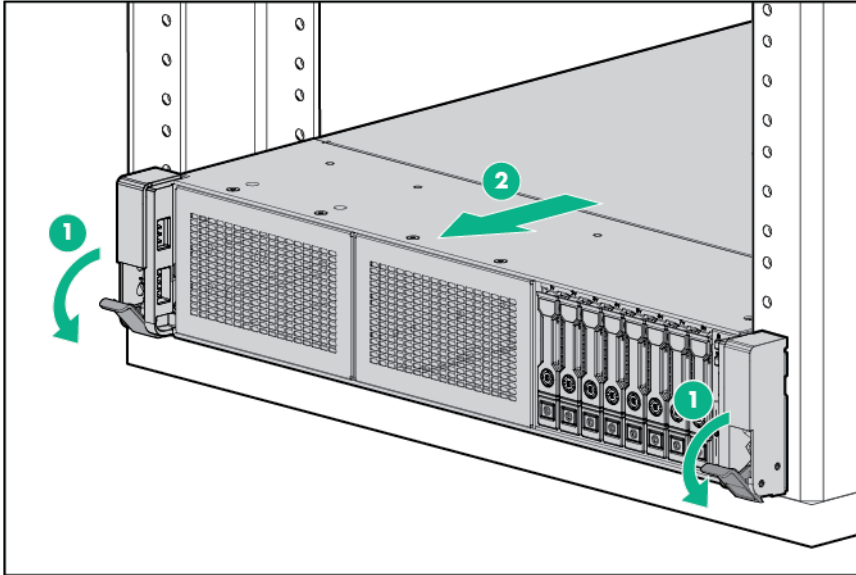

3. After performing the installation or maintenance procedure, slide the server back into the rack, and then press the server firmly into the rack to secure it in place.



**WARNING:** To reduce the risk of personal injury, be careful when pressing the server rail-release latches and sliding the server into the rack. The sliding rails could pinch your fingers.

## Remove the server from the rack

To remove the server from a Hewlett Packard Enterprise, Compaq-branded, Telco, or third-party rack:

1. Power down the server (on page 26).
2. Extend the server from the rack (on page 26).
3. Disconnect the cabling and remove the server from the rack. For more information, see the documentation that ships with the rack mounting option.
4. Place the server on a sturdy, level surface.

## Remove the access panel



**WARNING:** To reduce the risk of personal injury from hot surfaces, allow the drives and the internal system components to cool before touching them.



**CAUTION:** Do not operate the server for long periods with the access panel open or removed. Operating the server in this manner results in improper airflow and improper cooling that can lead to thermal damage.

To remove the component:

1. Power down the server (on page 26).
2. Extend the server from the rack (on page 26).
3. Open or unlock the locking latch, slide the access panel to the rear of the chassis, and remove the access panel.

## Install the access panel

1. Place the access panel on top of the server with the hood latch open. Allow the panel to extend past the rear of the server approximately 1.25 cm (0.5 in).
2. Push down on the hood latch. The access panel slides to a closed position.
3. Tighten the security screw on the hood latch.

## Access the product rear panel

To access the product rear panel, release the cable management arm and swing the arm away from the rack as indicated.

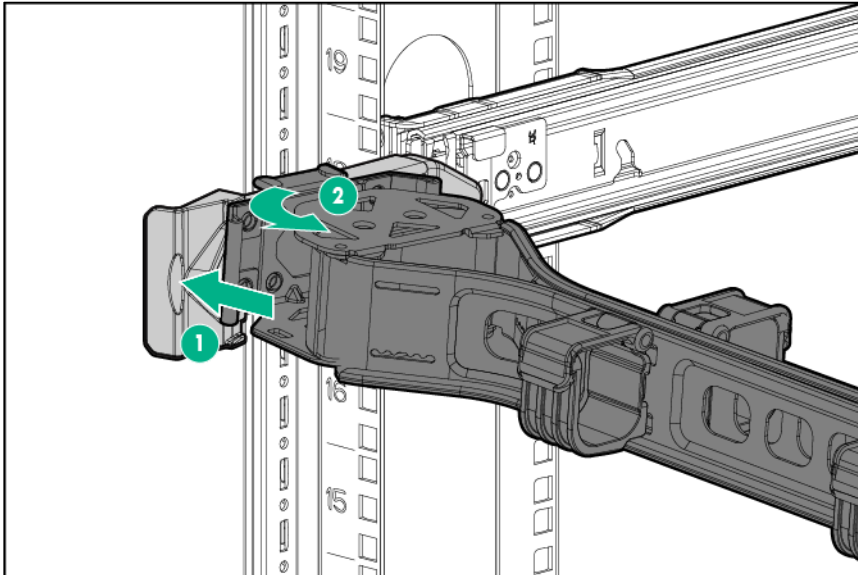

## Opening the cable management arm

To access the server rear panel:

1. Release the cable management arm.

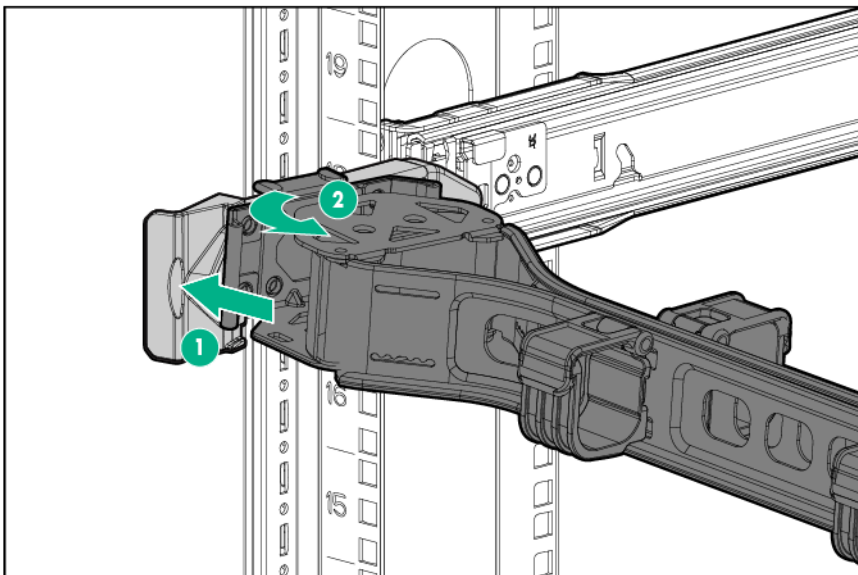

2. Open the cable management arm. The cable management arm can be right-mounted or left-mounted.

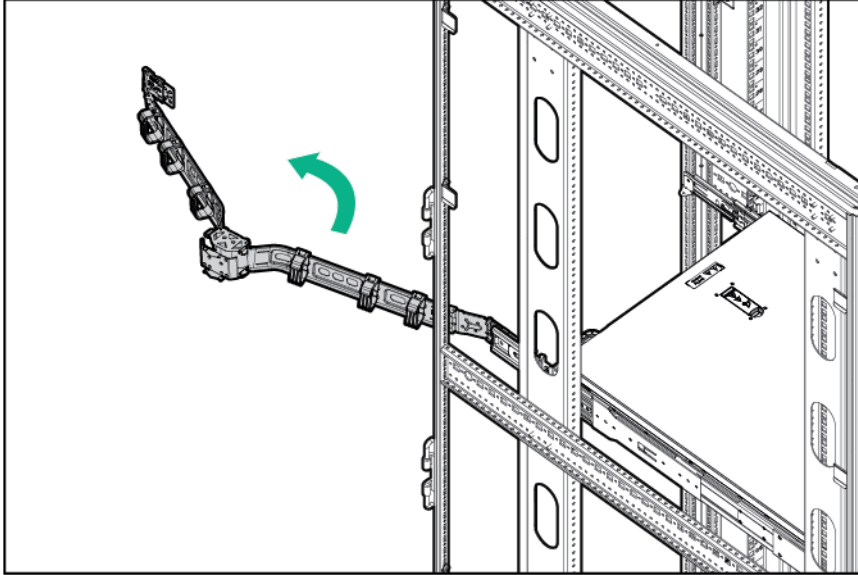

## Remove the fan cage

To remove the component:

1. Power down the server (on page 26).
2. Remove all power:
  - a. Disconnect each power cord from the power source.
  - b. Disconnect each power cord from the server.
3. Do one of the following:
  - o Extend the server from the rack (on page 26).
  - o Remove the server from the rack (on page 27).
4. Remove the access panel (on page 27).
5. Remove the fan cage.

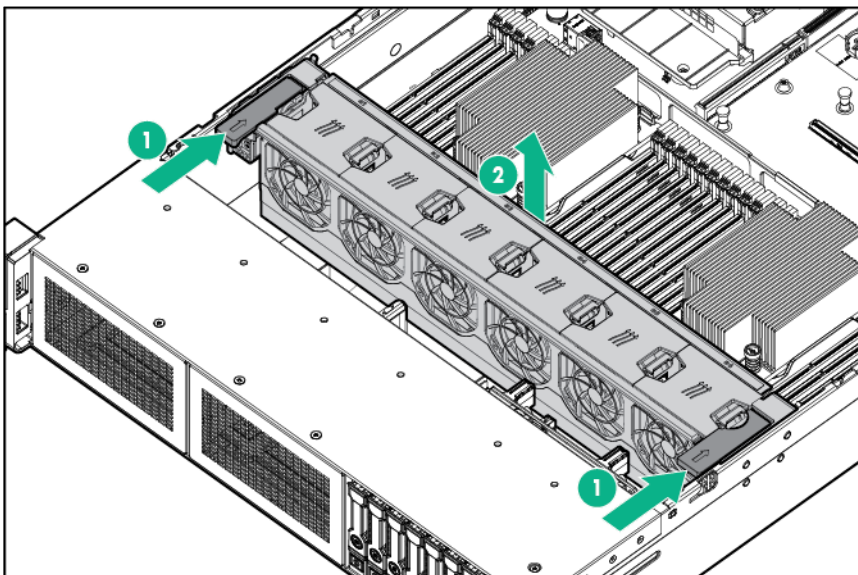

---

**CAUTION:** Do not operate the server for long periods with the access panel open or removed. Operating the server in this manner results in improper airflow and improper cooling that can lead to thermal damage.

---

**IMPORTANT:** For optimum cooling, install fans in all primary fan locations. For more information, refer to the fan locations table ("[Hot-plug fans](#)" on page 23).

---

## Remove the hot-plug fan

To remove the component:

1. Extend the server from the rack (on page 26).
2. Remove the access panel (on page 27).
3. Remove the fan.

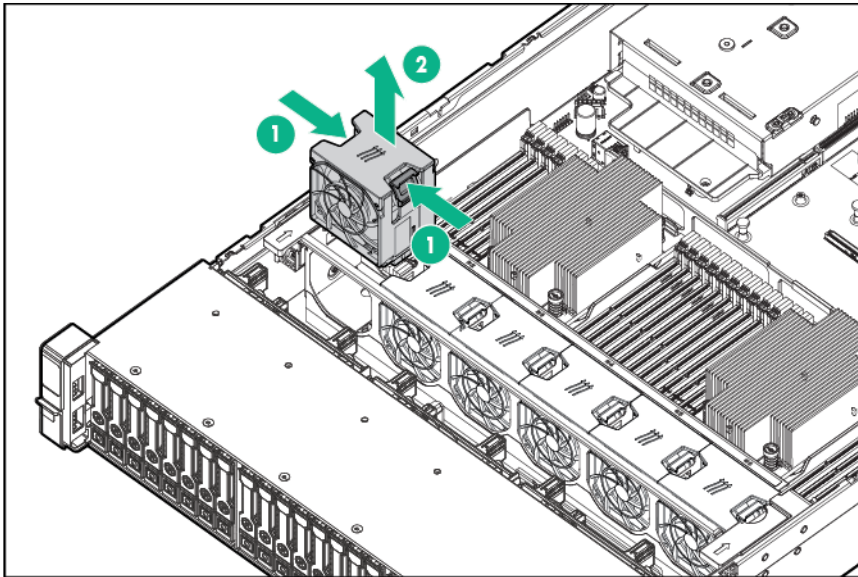

---

**CAUTION:** Do not operate the server for long periods with the access panel open or removed. Operating the server in this manner results in improper airflow and improper cooling that can lead to thermal damage.

---

**IMPORTANT:** For optimum cooling, install fans in all primary fan locations. For more information, refer to the fan locations table ("[Hot-plug fans](#)" on page 23).

---

## Remove the PCI riser cage

---

**CAUTION:** To prevent damage to the server or expansion boards, power down the server and remove all AC power cords before removing or installing the PCI riser cage.

---

1. Power down the server (on page 26).
2. Remove all power:
  - a. Disconnect each power cord from the power source.
  - b. Disconnect each power cord from the server.
3. Do one of the following:
  - o Extend the server from the rack (on page 26).

- o Remove the server from the rack (on page 27).
- 4. Remove the access panel (on page 27).
- 5. Remove the PCI riser cage.

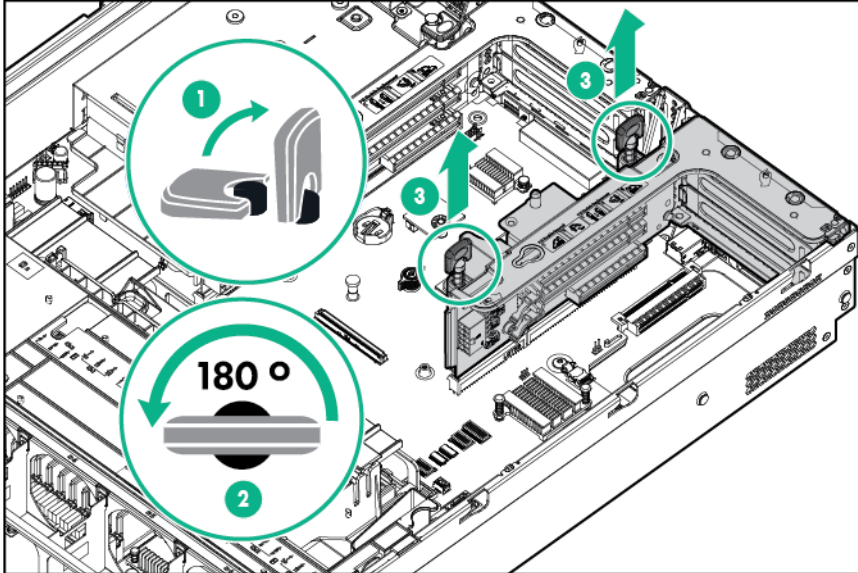

## Install the PCI riser cage

1. Power down the server (on page 26).
2. Remove all power:
  - a. Disconnect each power cord from the power source.
  - b. Disconnect each power cord from the server.
3. Do one of the following:
  - o Extend the server from the rack (on page 26).
  - o Remove the server from the rack (on page 27).
4. Remove the access panel (on page 27).
5. Install the PCI riser cage.

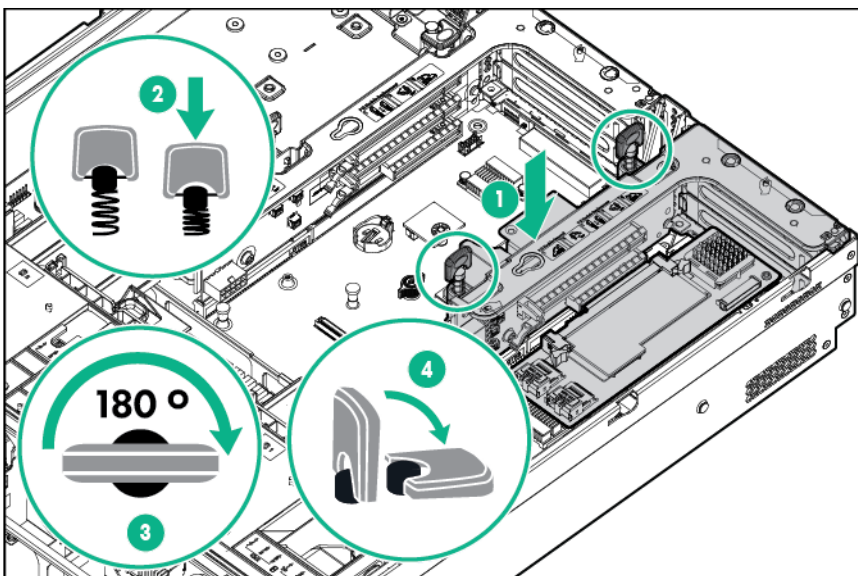

6. Install the access panel (on page 28).
7. Install the server into the rack ("Installing the server into the rack" on page 39).
8. Connect each power cord to the server.
9. Connect each power cord to the power source.
10. Power up the server ("Powering up the server" on page 26).

## Secure the full-length expansion board retainer

1. Power down the server (on page 26).
2. Remove all power:
  - a. Disconnect each power cord from the power source.
  - b. Disconnect each power cord from the server.
3. Extend the server from the rack (on page 26).
4. Remove the access panel (on page 27).
5. Install a full-length expansion board ("Installing an expansion board" on page 113).
6. Install the PCI riser cage (on page 31).
7. Secure the full-length expansion board retainer.

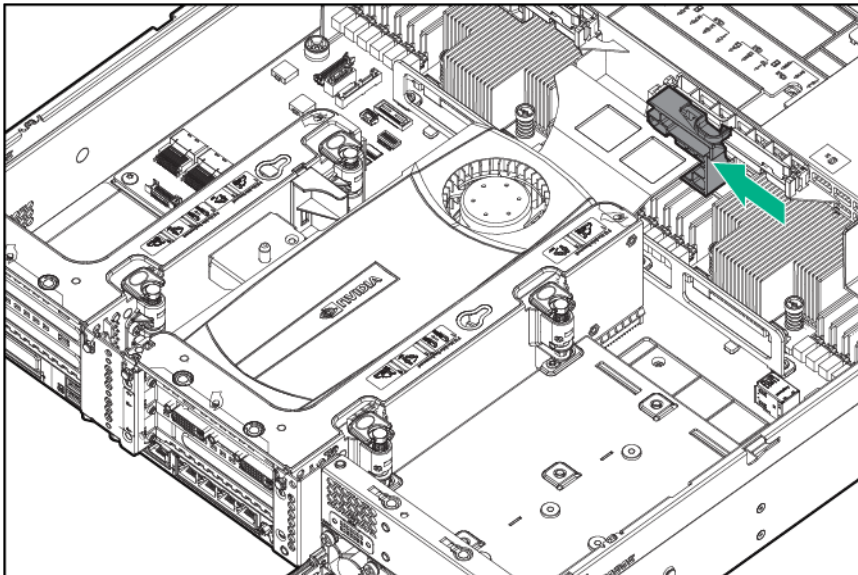

8. Install the access panel (on page 28).
9. Install the server into the rack ("Installing the server into the rack" on page 39).
10. Connect each power cord to the server.
11. Connect each power cord to the power source.
12. Power up the server ("Powering up the server" on page 26).

## Remove the air baffle

**CAUTION:** For proper cooling, do not operate the server without the access panel, baffles, expansion slot covers, or blanks installed. If the server supports hot-plug components, minimize the amount of time the access panel is open.

To remove the component:

1. Power down the server (on page 26).



2. Remove all power:
  - a. Disconnect each power cord from the power source.
  - b. Disconnect each power cord from the server.
3. Extend the server from the rack (on page 26).
4. Remove the access panel (on page 27).

---

△ **CAUTION:** Do not detach the cable that connects the battery pack to the cache module. Detaching the cable causes any unsaved data in the cache module to be lost.

---

5. Remove the air baffle.

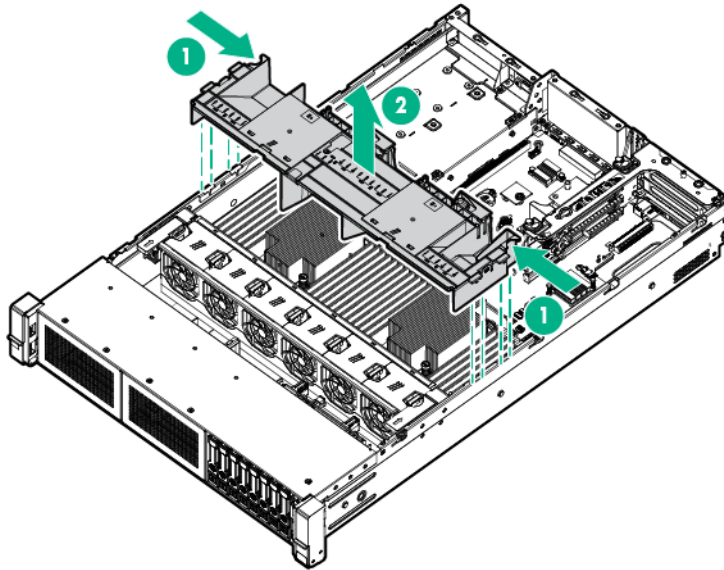

## Install the air baffle

---

△ **CAUTION:** For proper cooling, do not operate the server without the access panel, baffles, expansion slot covers, or blanks installed. If the server supports hot-plug components, minimize the amount of time the access panel is open.

---

To remove the component:

1. Power down the server (on page 26).
2. Remove all power:
  - a. Disconnect each power cord from the power source.
  - b. Disconnect each power cord from the server.
3. Extend the server from the rack (on page 26).
4. Remove the access panel (on page 27).

---

△ **CAUTION:** Do not detach the cable that connects the battery pack to the cache module. Detaching the cable causes any unsaved data in the cache module to be lost.

---

5. Install the air baffle.

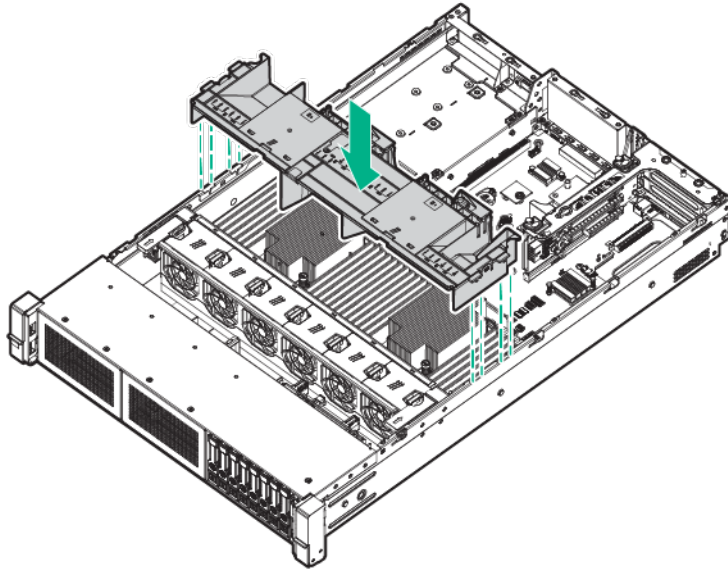

# Setup

## Optional services

Delivered by experienced, certified engineers, HPE support services help you keep your servers up and running with support packages tailored specifically for HPE ProLiant systems. HPE support services let you integrate both hardware and software support into a single package. A number of service level options are available to meet your business and IT needs.

HPE support services offer upgraded service levels to expand the standard product warranty with easy-to-buy, easy-to-use support packages that will help you make the most of your server investments. Some of the HPE support services for hardware, software or both are:

- Foundation Care – Keep systems running.
  - 6-Hour Call-to-Repair
  - 4-Hour 24x7
  - Next Business Day
- Proactive Care – Help prevent service incidents and get you to technical experts when there is one.
  - 6-Hour Call-to-Repair
  - 4-Hour 24x7
  - Next Business Day
- Startup and implementation services for both hardware and software
- HPE Education Services – Help train your IT staff.

For more information on HPE support services, see the Hewlett Packard Enterprise website (<http://www.hpe.com/services>).

## Optimum environment

When installing the server in a rack, select a location that meets the environmental standards described in this section.

### Space and airflow requirements

To allow for servicing and adequate airflow, observe the following space and airflow requirements when deciding where to install a rack:

- Leave a minimum clearance of 63.5 cm (25 in) in front of the rack.
- Leave a minimum clearance of 76.2 cm (30 in) behind the rack.
- Leave a minimum clearance of 121.9 cm (48 in) from the back of the rack to the back of another rack or row of racks.

Hewlett Packard Enterprise servers draw in cool air through the front door and expel warm air through the rear door. Therefore, the front and rear rack doors must be adequately ventilated to allow ambient room air to enter the cabinet, and the rear door must be adequately ventilated to allow the warm air to escape from the cabinet.

---

 **CAUTION:** To prevent improper cooling and damage to the equipment, do not block the ventilation openings.

---

When vertical space in the rack is not filled by a server or rack component, the gaps between the components cause changes in airflow through the rack and across the servers. Cover all gaps with blanking panels to maintain proper airflow.

 **CAUTION:** Always use blanking panels to fill empty vertical spaces in the rack. This arrangement ensures proper airflow. Using a rack without blanking panels results in improper cooling that can lead to thermal damage.

---

The 9000 and 10000 Series Racks provide proper server cooling from flow-through perforations in the front and rear doors that provide 64 percent open area for ventilation.

 **CAUTION:** When using a Compaq branded 7000 series rack, install the high airflow rack door insert (PN 327281-B21 for 42U rack, PN 157847-B21 for 22U rack) to provide proper front-to-back airflow and cooling.

---

 **CAUTION:** If a third-party rack is used, observe the following additional requirements to ensure adequate airflow and to prevent damage to the equipment:

- Front and rear doors—If the 42U rack includes closing front and rear doors, you must allow 5,350 sq cm (830 sq in) of holes evenly distributed from top to bottom to permit adequate airflow (equivalent to the required 64 percent open area for ventilation).
- Side—The clearance between the installed rack component and the side panels of the rack must be a minimum of 7 cm (2.75 in).

---

 **IMPORTANT:** The HPE ProLiant DL380 Gen9 Server cable management arm is not supported on Compaq branded 7000 series racks.

---

## Temperature requirements

To ensure continued safe and reliable equipment operation, install or position the system in a well-ventilated, climate-controlled environment.

The maximum recommended ambient operating temperature (TMRA) for most server products is 35°C (95°F). The temperature in the room where the rack is located must not exceed 35°C (95°F).

 **CAUTION:** To reduce the risk of damage to the equipment when installing third-party options:

- Do not permit optional equipment to impede airflow around the server or to increase the internal rack temperature beyond the maximum allowable limits.
- Do not exceed the manufacturer's TMRA.

---

## Power requirements

Installation of this equipment must comply with local and regional electrical regulations governing the installation of information technology equipment by licensed electricians. This equipment is designed to operate in installations covered by NFPA 70, 1999 Edition (National Electric Code) and NFPA-75, 1992 (code for Protection of Electronic Computer/Data Processing Equipment). For electrical power ratings on options, refer to the product rating label or the user documentation supplied with that option.

 **WARNING:** To reduce the risk of personal injury, fire, or damage to the equipment, do not overload the AC supply branch circuit that provides power to the rack. Consult the electrical authority having jurisdiction over wiring and installation requirements of your facility.

---

- 
-  **CAUTION:** Protect the server from power fluctuations and temporary interruptions with a regulating uninterruptible power supply. This device protects the hardware from damage caused by power surges and voltage spikes and keeps the system in operation during a power failure.
- 

When installing more than one server, you may need to use additional power distribution devices to safely provide power to all devices. Observe the following guidelines:





- Balance the server power load between available AC supply branch circuits.
- Do not allow the overall system AC current load to exceed 80% of the branch circuit AC current rating.
- Do not use common power outlet strips for this equipment.
- Provide a separate electrical circuit for the server.

## Electrical grounding requirements

The server must be grounded properly for proper operation and safety. In the United States, you must install the equipment in accordance with NFPA 70, 1999 Edition (National Electric Code), Article 250, as well as any local and regional building codes. In Canada, you must install the equipment in accordance with Canadian Standards Association, CSA C22.1, Canadian Electrical Code. In all other countries, you must install the equipment in accordance with any regional or national electrical wiring codes, such as the International Electrotechnical Commission (IEC) Code 364, parts 1 through 7. Furthermore, you must be sure that all power distribution devices used in the installation, such as branch wiring and receptacles, are listed or certified grounding-type devices.

Because of the high ground-leakage currents associated with multiple servers connected to the same power source, Hewlett Packard Enterprise recommends the use of a PDU that is either permanently wired to the building's branch circuit or includes a nondetachable cord that is wired to an industrial-style plug. NEMA locking-style plugs or those complying with IEC 60309 are considered suitable for this purpose. Using common power outlet strips for the server is not recommended.

## Connecting a DC power cable to a DC power source

- 
-  **WARNING:** To reduce the risk of electric shock or energy hazards:
- This equipment must be installed by trained service personnel, as defined by the NEC and IEC 60950-1, Second Edition, the standard for Safety of Information Technology Equipment.
  - Connect the equipment to a reliably grounded Secondary circuit source. A Secondary circuit has no direct connection to a Primary circuit and derives its power from a transformer, converter, or equivalent isolation device.
  - The branch circuit overcurrent protection must be rated 27 A.
- 
-  **WARNING:** When installing a DC power supply, the ground wire must be connected before the positive or negative leads.
- 
-  **WARNING:** Remove power from the power supply before performing any installation steps or maintenance on the power supply.
- 
-  **CAUTION:** The server equipment connects the earthed conductor of the DC supply circuit to the earthing conductor at the equipment. For more information, see the documentation that ships with the power supply.
-

- 
-  **CAUTION:** If the DC connection exists between the earthed conductor of the DC supply circuit and the earthing conductor at the server equipment, the following conditions must be met:
- This equipment must be connected directly to the DC supply system earthing electrode conductor or to a bonding jumper from an earthing terminal bar or bus to which the DC supply system earthing electrode conductor is connected.
  - This equipment should be located in the same immediate area (such as adjacent cabinets) as any other equipment that has a connection between the earthed conductor of the same DC supply circuit and the earthing conductor, and also the point of earthing of the DC system. The DC system should be earthed elsewhere.
  - The DC supply source is to be located within the same premises as the equipment.
  - Switching or disconnecting devices should not be in the earthed circuit conductor between the DC source and the point of connection of the earthing electrode conductor.
- 

To connect a DC power cable to a DC power source:

1. Cut the DC power cord ends no shorter than 150 cm (59.06 in).
2. If the power source requires ring tongues, use a crimping tool to install the ring tongues on the power cord wires.



---

**IMPORTANT:** The ring terminals must be UL approved and accommodate 12 gauge wires.

---



---

**IMPORTANT:** The minimum nominal thread diameter of a pillar or stud type terminal must be 3.5 mm (0.138 in); the diameter of a screw type terminal must be 4.0 mm (0.157 in).

---

3. Stack each same-colored pair of wires and then attach them to the same power source. The power cord consists of three wires (black, red, and green).

For more information, see the documentation that ships with the power supply.

## Rack warnings



---

**WARNING:** To reduce the risk of personal injury or damage to the equipment, be sure that:

- The leveling jacks are extended to the floor.
  - The full weight of the rack rests on the leveling jacks.
  - The stabilizing feet are attached to the rack if it is a single-rack installation.
  - The racks are coupled together in multiple-rack installations.
  - Only one component is extended at a time. A rack may become unstable if more than one component is extended for any reason.
- 



---

**WARNING:** To reduce the risk of personal injury or equipment damage when unloading a rack:

- At least two people are needed to safely unload the rack from the pallet. An empty 42U rack can weigh as much as 115 kg (253 lb), can stand more than 2.1 m (7 ft) tall, and might become unstable when being moved on its casters.
  - Never stand in front of the rack when it is rolling down the ramp from the pallet. Always handle the rack from both sides.
- 

## Identifying the contents of the server shipping carton

Unpack the server shipping carton and locate the materials and documentation necessary for installing the server. All the rack mounting hardware necessary for installing the server into the rack is included with the rack or the server.

The contents of the server shipping carton include:

- Server
- Power cord
- Hardware documentation and software products
- Rack-mounting hardware and documentation

In addition to the supplied items, you might need:

- Operating system or application software
- Hardware options
- Screwdriver

## Installing hardware options

Install any hardware options before initializing the server. For options installation information, refer to the option documentation. For server-specific information, refer to "Hardware options installation (on page 43)."

## Installing the server into the rack

**CAUTION:** Always plan the rack installation so that the heaviest item is on the bottom of the rack. Install the heaviest item first, and continue to populate the rack from the bottom to the top.

1. Install the server and cable management arm into the rack. For more information, see the installation instructions that ship with the 2U Quick Deploy Rail System.
2. Connect peripheral devices to the server. For information on identifying connectors, see "Rear panel components (on page 14)."

**WARNING:** To reduce the risk of electric shock, fire, or damage to the equipment, do not plug telephone or telecommunications connectors into RJ-45 connectors.

3. Connect the power cord to the rear of the server.
4. Install the power cord anchors.

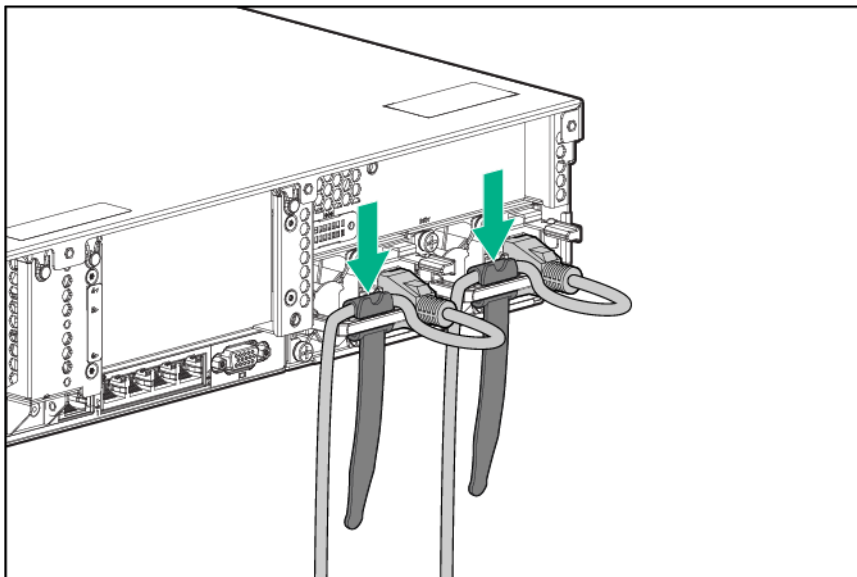

5. Secure the cables to the cable management arm.



---

**IMPORTANT:** When using cable management arm components, be sure to leave enough slack in each of the cables to prevent damage to the cables when the server is extended from the rack.

---

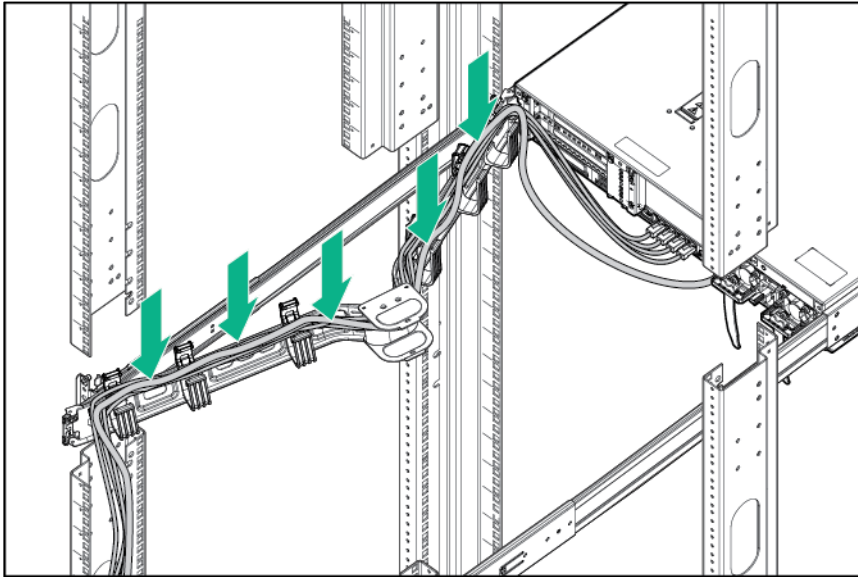

6. Connect the power cord to the AC power source.



**WARNING:** To reduce the risk of electric shock or damage to the equipment:

- Do not disable the power cord grounding plug. The grounding plug is an important safety feature.
  - Plug the power cord into a grounded (earthed) electrical outlet that is easily accessible at all times.
  - Unplug the power cord from the power supply to disconnect power to the equipment.
  - Do not route the power cord where it can be walked on or pinched by items placed against it. Pay particular attention to the plug, electrical outlet, and the point where the cord extends from the server.
- 

## Installing the operating system

This ProLiant server does not ship with provisioning media. Everything needed to manage and install the system software and firmware is preloaded on the server.

To operate properly, the server must have a supported operating system. Attempting to run an unsupported operating system can cause serious and unpredictable results. For the latest information on operating system support, see the Hewlett Packard Enterprise website (<http://www.hpe.com/info/supportos>).

Failure to observe UEFI requirements for ProLiant Gen9 servers can result in errors installing the operating system, failure to recognize boot media, and other boot failures. For more information on these requirements, see the *HPE UEFI Requirements* on the Hewlett Packard Enterprise website (<http://www.hpe.com/info/ProLiantUEFI/docs>).

To install an operating system on the server, use one of the following methods:

- Intelligent Provisioning—For single-server deployment, updating, and provisioning capabilities.  
To install an operating system on the server with Intelligent Provisioning (local or remote):
  - a. Connect the Ethernet cable between the network connector on the server and a network jack.
  - b. Press the Power On/Standby button.



- c. During server POST, press **F10**.
  - d. Complete the initial Preferences and Registration portion of Intelligent Provisioning (on page 172).
  - e. At the 1 Start screen, click **Configure and Install**.
  - f. To finish the installation, follow the onscreen prompts. An Internet connection is required to update the firmware and systems software.
- Insight Control server provisioning—For multi-server remote OS deployment, use Insight Control server provisioning for an automated solution. For more information, see the Insight Control documentation on the Hewlett Packard Enterprise website (<http://www.hpe.com/info/insightcontrol/docs>).

For additional system software and firmware updates, download the Service Pack for ProLiant from the Hewlett Packard Enterprise website (<http://www.hpe.com/servers/spp/download>). Software and firmware must be updated before using the server for the first time, unless any installed software or components require an older version.

For more information, see "Keeping the system current (on page 179)."

For more information on using these installation methods, see the Hewlett Packard Enterprise website (<http://www.hpe.com/info/ilo>).

## Powering on and selecting boot options in UEFI Boot Mode

On servers operating in UEFI Boot Mode, the boot controller and boot order are set automatically.

1. Press the Power On/Standby button.
2. During the initial boot:
  - o To modify the server configuration ROM default settings, press the **F9** key in the ProLiant POST screen to enter the UEFI System Utilities screen. By default, the System Utilities menus are in the English language.
  - o If you do not need to modify the server configuration and are ready to install the system software, press the **F10** key to access Intelligent Provisioning.

For more information on automatic configuration, see the UEFI documentation on the Hewlett Packard Enterprise website (<http://www.hpe.com/info/ProLiantUEFI/docs>).

## Powering on and selecting boot options

This server supports both Legacy BIOS Boot Mode and UEFI Boot Mode. On servers operating in UEFI Boot Mode, the boot controller and boot order are set automatically.

1. Press the Power On/Standby button.
2. Do one of the following:
  - a. To enter the UEFI System Utilities screen and modify the server configuration ROM default settings, press the **F9** key on the ProLiant POST screen. Choose one of the following boot modes:
    - Legacy BIOS
    - UEFI (default)
  - b. If you do not need to modify the server configuration and are ready to install the system software, press the **F10** key to access Intelligent Provisioning.

For more information on automatic configuration, see the UEFI documentation on the Hewlett Packard Enterprise website (<http://www.hpe.com/info/ProLiantUEFI/docs>).

# Registering the server

To experience quicker service and more efficient support, register the product at the Hewlett Packard Enterprise Product Registration website (<http://www.hpe.com/info/register>).

# Hardware options installation

## Hewlett Packard Enterprise product QuickSpecs

For more information about product features, specifications, options, configurations, and compatibility, see the product QuickSpecs on the Hewlett Packard Enterprise website (<http://www.hpe.com/info/qs>).

### Introduction

If more than one option is being installed, read the installation instructions for all the hardware options and identify similar steps to streamline the installation process.



---

**WARNING:** To reduce the risk of personal injury from hot surfaces, allow the drives and the internal system components to cool before touching them.

---



---

**CAUTION:** To prevent damage to electrical components, properly ground the server before beginning any installation procedure. Improper grounding can cause electrostatic discharge.

---

### Hot-plug drive guidelines

When adding drives to the server, observe the following general guidelines:

- The system automatically sets all device numbers.
- If only one drive is used, install it in the bay with the lowest device number.
- Drives should be the same capacity to provide the greatest storage space efficiency when drives are grouped together into the same drive array.

### Drive options

Depending on the configuration, this server supports SAS, SATA, and NVMe drives. For more information on drive support, see "Device bay numbering ("[SAS and SATA device numbers](#)" on page 19)."

When adding hard drives to the server, observe the following general guidelines:

- The system automatically sets all device numbers.
- If only one hard drive is used, install it in the bay with the lowest device number.
- Drives should be the same capacity to provide the greatest storage space efficiency when drives are grouped together into the same drive array.

## Removing the hard drive blank

Remove the component as indicated.

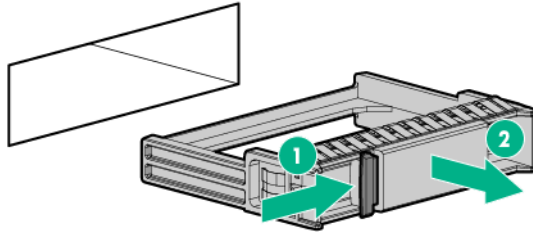

## Installing a hot-plug SAS or SATA drive

To install the component:

1. Remove the drive blank.

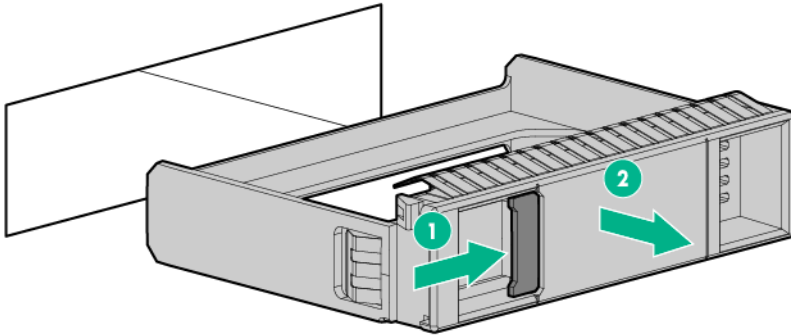

2. Prepare the drive.

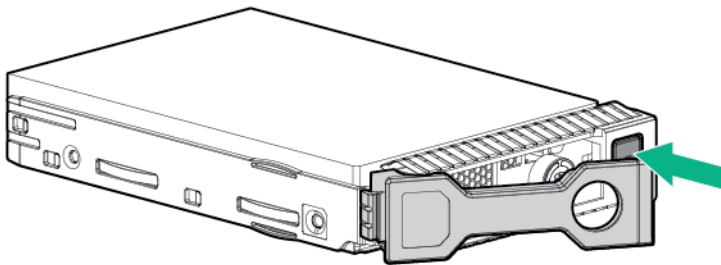

3. Install the drive.

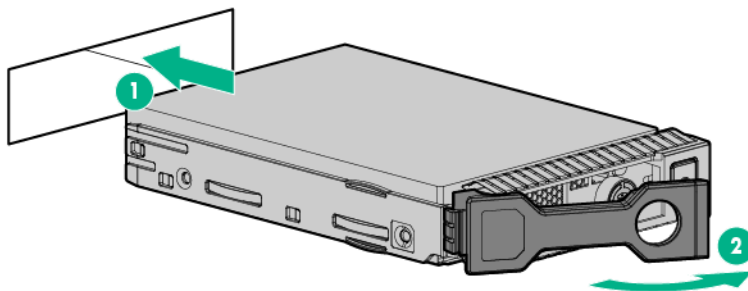

4. Determine the status of the drive from the drive LED definitions ("[Hot-plug drive LED definitions](#)" on page 22).

## Removing a hot-plug SAS or SATA hard drive

**CAUTION:** For proper cooling, do not operate the server without the access panel, baffles, expansion slot covers, or blanks installed. If the server supports hot-plug components, minimize the amount of time the access panel is open.

1. Determine the status of the drive from the hot-plug drive LED definitions (on page 22).
2. Back up all server data on the drive.
3. Remove the drive.

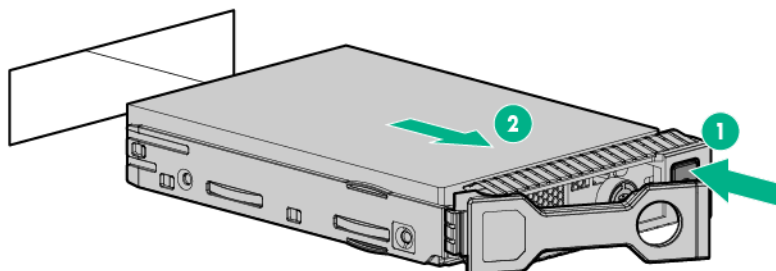

## Installing the NVMe drives

NVMe drives are supported on this server when the 8SFF drive cage and/or the 2SFF drive cage is installed. For more information on which bays support NVMe drives, see "[Device numbers \(\"SAS and SATA device numbers](#)" on page 19)."

To install the drives:

**CAUTION:** To prevent improper cooling and thermal damage, do not operate the server or the enclosure unless all drive and device bays are populated with either a component or a blank.

1. Remove the drive blank, if installed.

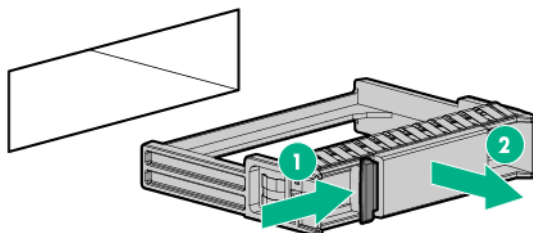

2. Press the Do Not Remove button to open the release handle.

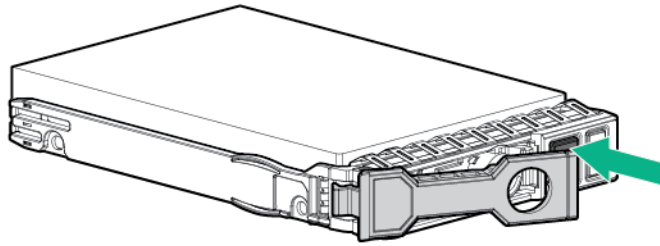

3. Install the drives.

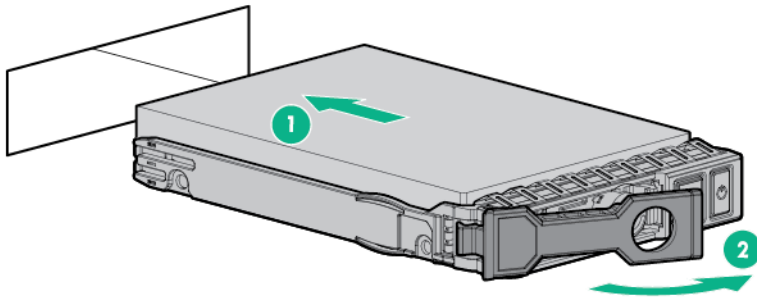

4. Install an SFF drive blank in any unused drive bays.

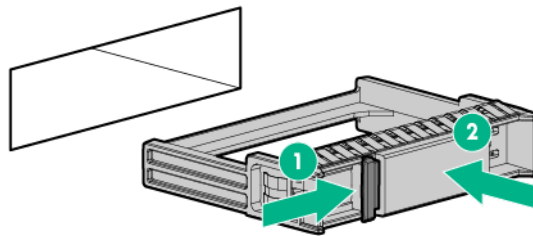

## Express Bay drive cage

The high-performance fan option (part number 719079-B21) must be installed when installing this option.

With the 6SFF Express bay Enablement option installed, the server supports SAS drives, SATA drives, SSDs, and NVMe drives in the following locations:

- Optional 2SFF drive cage installed either in Universal media bay 1 or at the rear of the server supports SFF SAS drives, SATA drives, or SSDs.
- 8SFF drive cage (bays 1 to 8) installed in box 1 supports SFF SAS drives, SATA drives, or SSDs.
- 6SFF Express Bay Enablement option (bays 1 to 6) installed in Universal media bay 2 (box 2) supports SFF NVMe drives.

For more information about NVMe SSDs, see the Hewlett Packard Enterprise website ([http://www.hpe.com/support/NVMeDrive\\_en](http://www.hpe.com/support/NVMeDrive_en)). For more information on supported drives, see the Hewlett Packard Enterprise website (<http://www.hpe.com/info/qs>). For more information on which bays support NVMe drives, see "Device numbers ("SAS and SATA device numbers" on page 19)."

# Installing the airflow labels

When installing the HPE Express Bay drive cage in bay two, the airflow labels included in the kit must be installed depending on the option installed in bay one:

- If the Eight-bay SFF Front Drive Cage option is installed in bay one, then no further action is required.
- If the Two-bay SFF Drive Cage option is not installed in the Universal Media Bay in bay one, then install the two small Universal media bay airflow labels (814815-001) and the Universal media bay 2 SFF drive airflow label (814816-001).

If no DVD is installed in the Universal media bay, then install the DVD airflow label (828649-001).

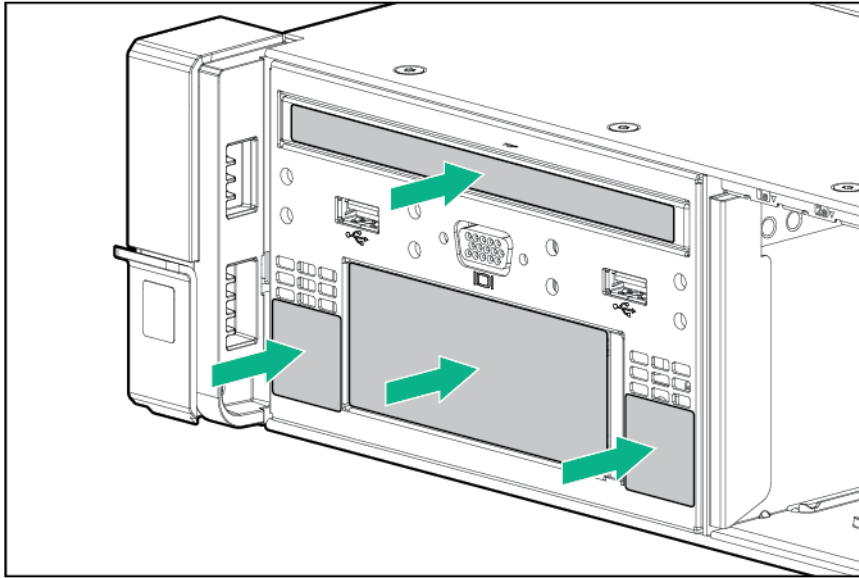

- If the Two-bay SFF Drive Cage option is installed in the Universal media bay in bay one and two SFF drives are installed, then install the two small Universal media bay airflow labels (814815-001) as indicated.

If no DVD is installed in the Universal media bay, then install the DVD airflow label (828649-001).

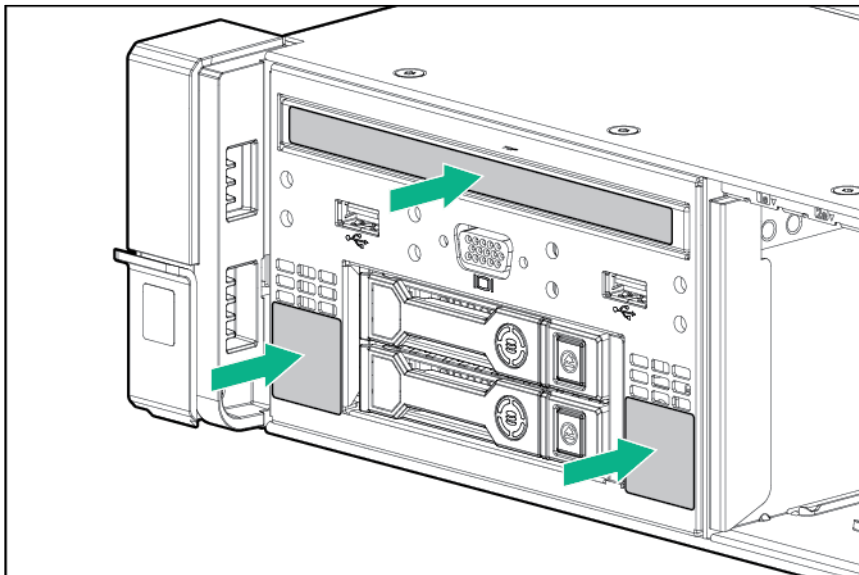

- If a blank is installed in bay one, then install the Drive bay 1 airflow label (814814-001) as indicated.

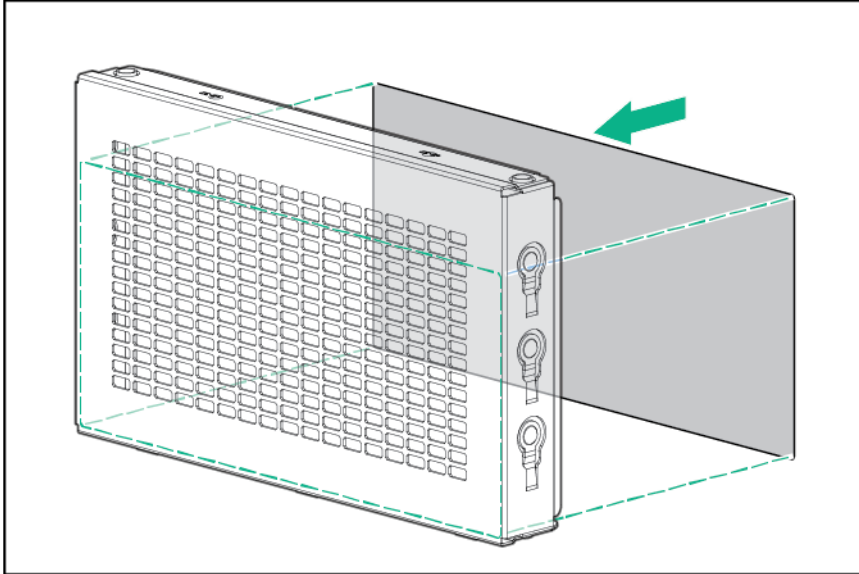

## Installing the Express Bay drive cage

**⚠ WARNING:** To reduce the risk of personal injury from hot surfaces, allow the drives and the internal system components to cool before touching them.

**⚠ CAUTION:** To prevent damage to electrical components, properly ground the server before beginning any installation procedure. Improper grounding can cause ESD.

To install the component:

1. Back up all server data.
2. Power down the server (on page 26).
3. Do one of the following:
  - Extend the server from the rack (on page 26).
  - Remove the server from the rack (on page 27).
4. Remove the access panel (on page 27).
5. Remove the air baffle (on page 32).
6. Remove the fan cage (on page 29).



7. Remove the bay 2 blank.

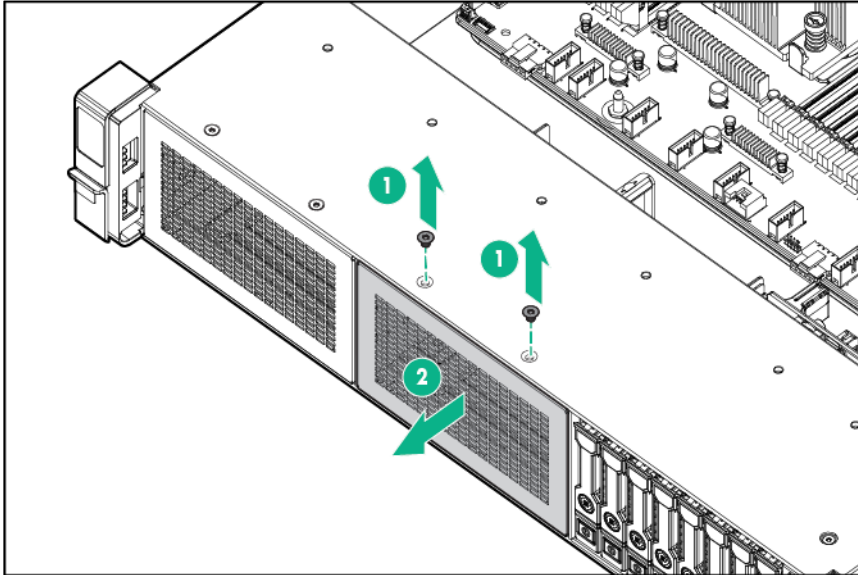

8. If drive blanks are installed in the drive cage assembly, remove the drive blanks ("Removing the hard drive blank" on page 44). Retain the drive blanks for use in empty drive bays.
9. Install the HPE Express Bay drive cage.

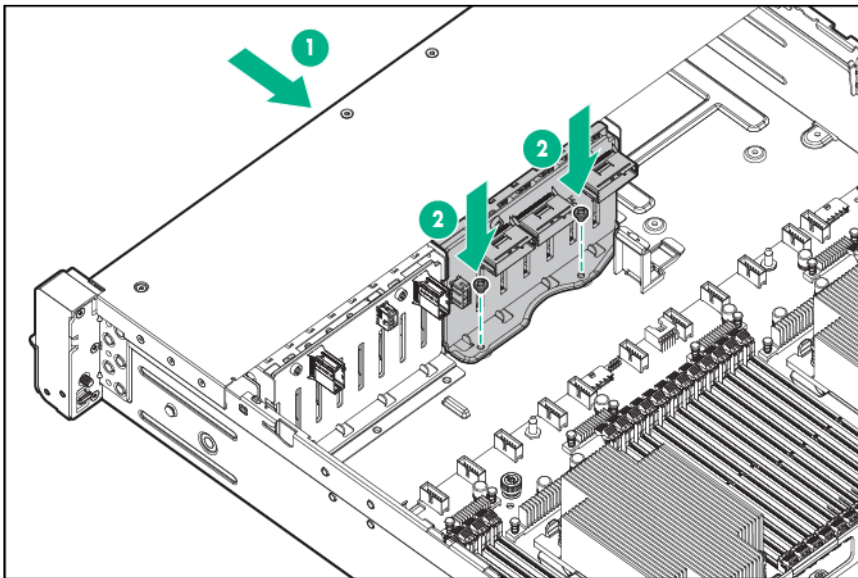

10. Connect the power cable depending on the server configuration.

- o 8SFF drive cage installed in bay 1 — Use the 8SFF drive cage power cable (776399-001).

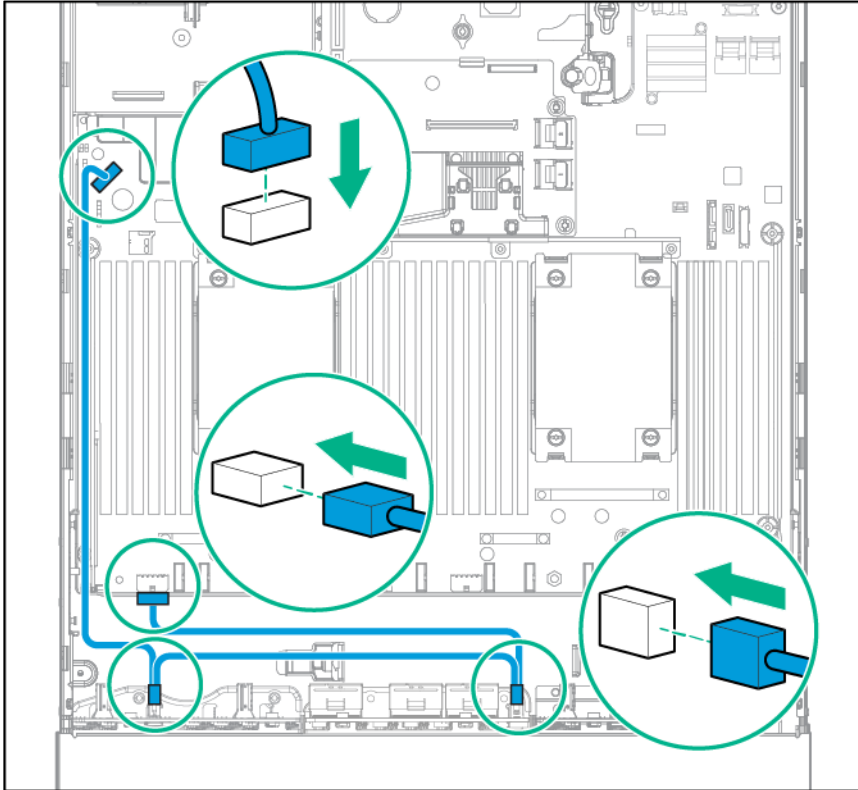

- 8SFF drive cage installed in bay 1 and 2 SFF drives in the rear of the server — Use the 8SFF drive cage power cable (776399-001) and the 2SFF drives-rear power cable (776400-001).

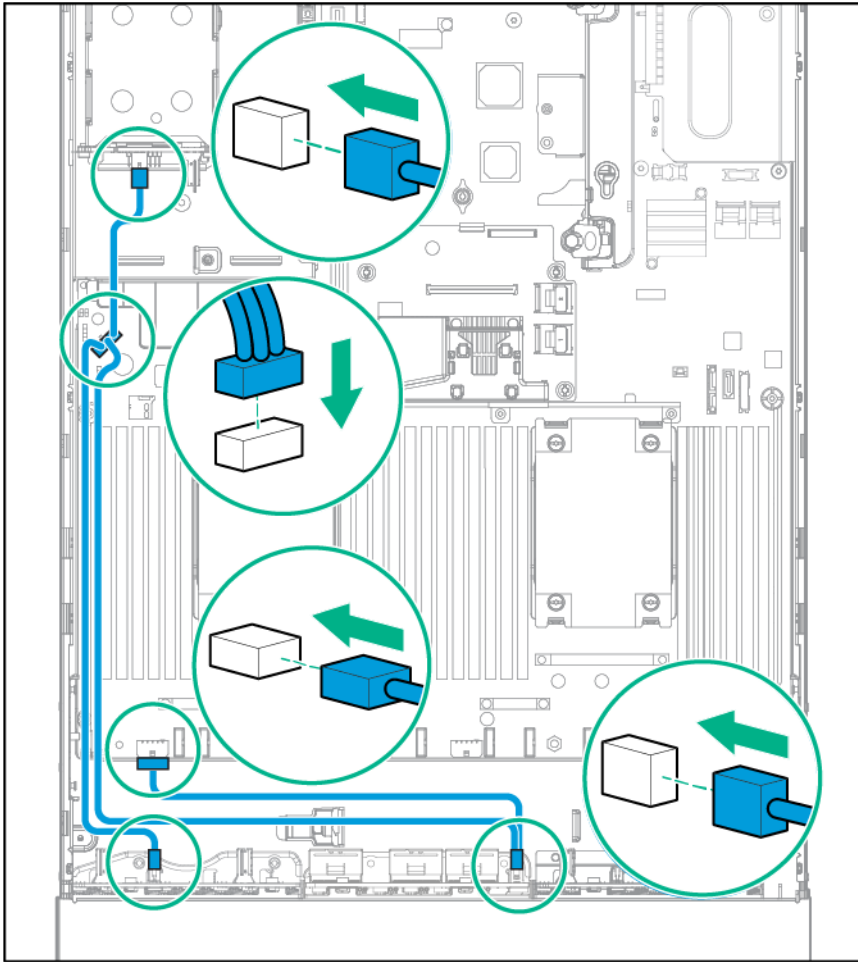

- o Drive bay 1 is empty — Use the NVMe power cable (776392-001).

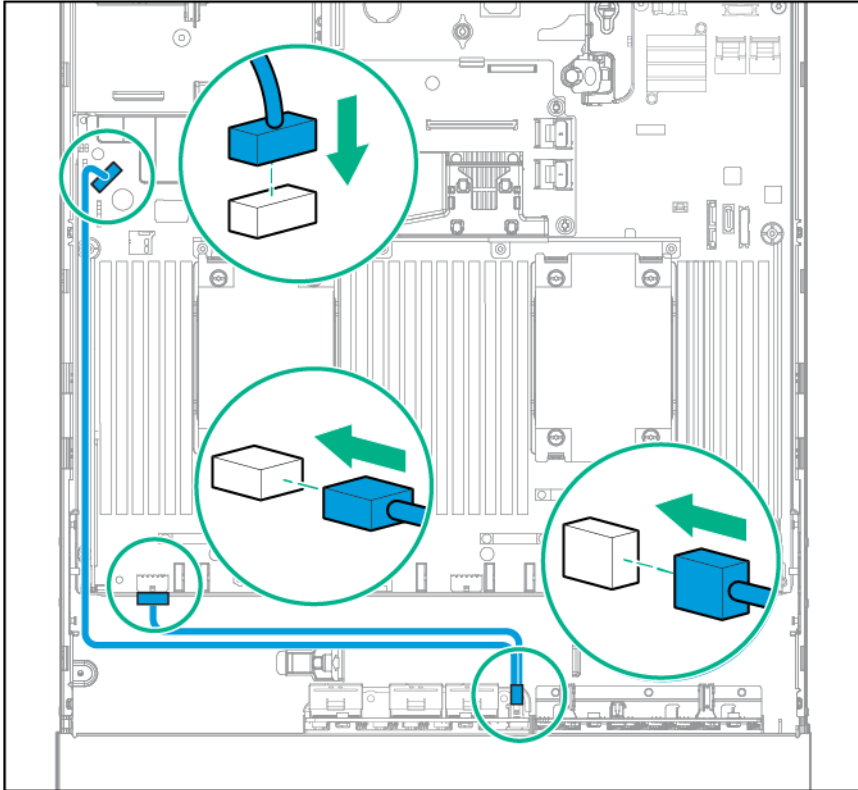

- o 8SFF drive cage installed in bay 1 and 2SFF drives in the front of the server — Use the 8SFF drive cage power cable (776399-001) and the 2SFF drives-front power cable (795156-001).

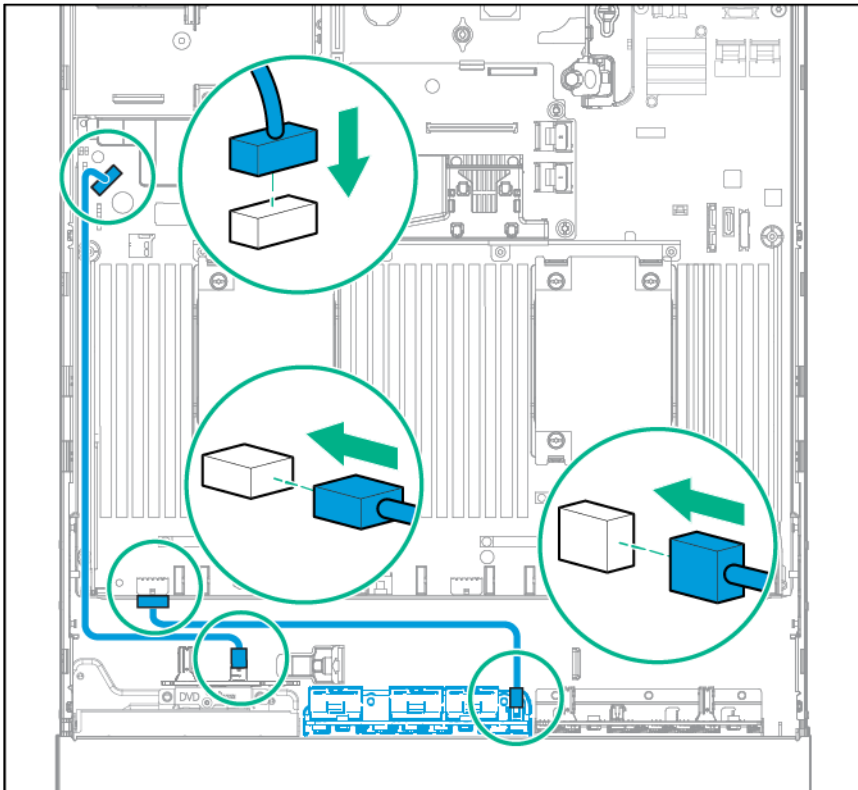

11. Remove the primary PCI riser cage ("[Remove the PCI riser cage](#)" on page 30).

12. Remove the expansion slot blank from slot 2.

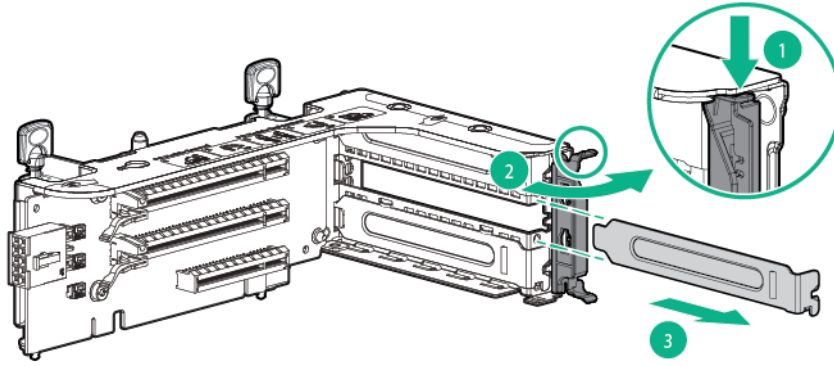

13. Install the HPE Express Bay Bridge Card.

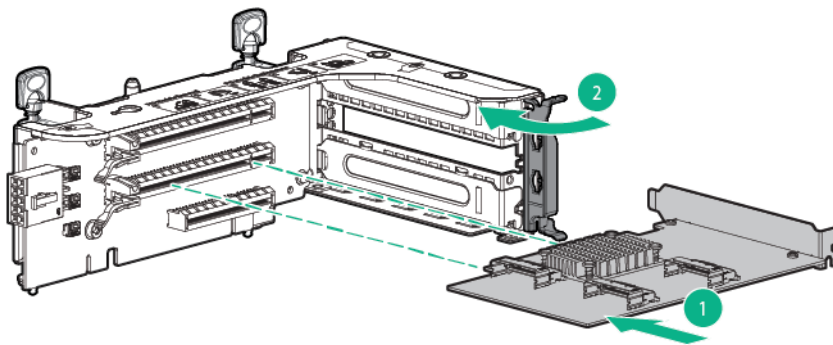

- Using the cable trough and clips, connect the NVMe data cable (826898-001) to the HPE Express Bay Bridge Card. If the HPE 12G SAS Expander Card is installed, install the 12G SAS expander card cable (776402-001) (not shown).

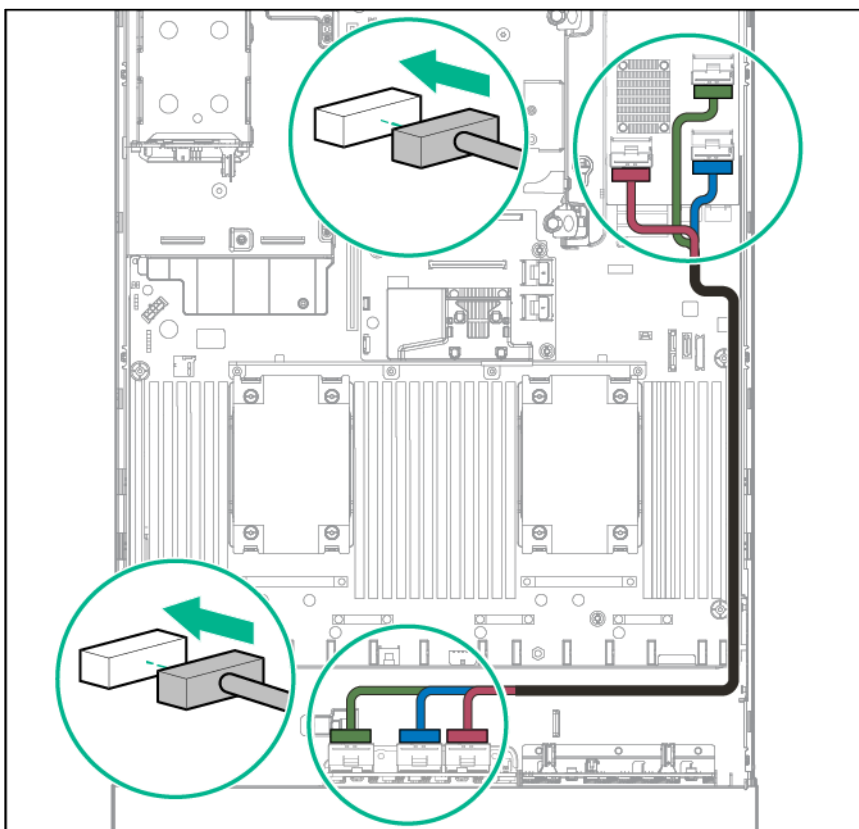

- Install the drives ("[Installing a hot-plug SAS or SATA drive](#)" on page 44).

**CAUTION:** To prevent improper cooling and thermal damage, do not operate the server unless all bays are populated with either a component or a blank.

- Install the drive blank in any unused drive bays.

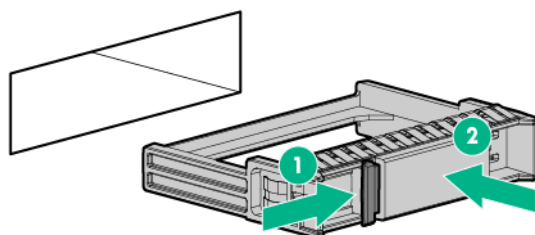

17. Install the fan cage. The fan cage should be populated with high-performance fans when installing the Express Bay Enablement option.

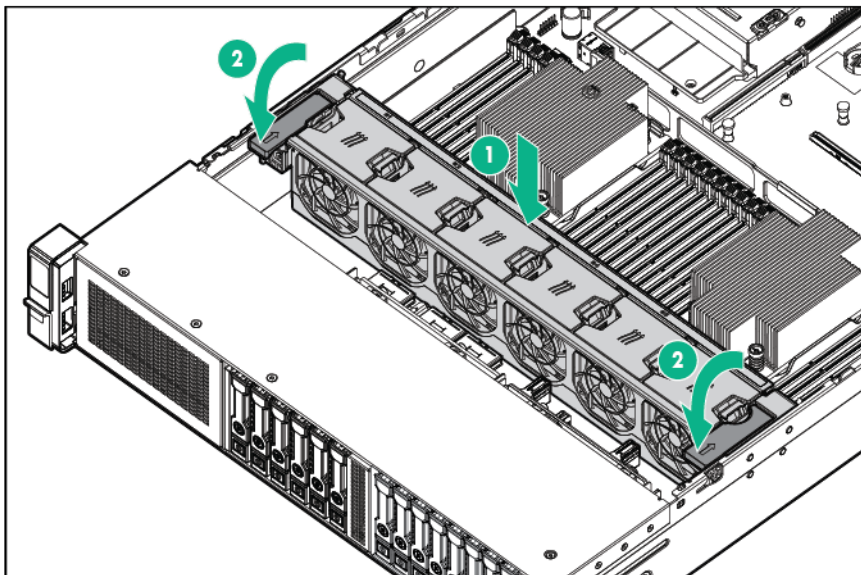

18. Install the air baffle (on page 33).
19. Install the access panel (on page 28).
20. Do one of the following:
  - o Slide the server into the rack.
  - o Install the server into the rack.
21. Connect each power cord to the server.
22. Connect each power cord to the power source.
23. Power up the server ("[Powering up the server](#)" on page 26).

## Redundant hot-plug power supply option

- 
- CAUTION:** All power supplies installed in the server must have the same output power capacity. Verify that all power supplies have the same part number and label color. The system becomes unstable and may shut down when it detects mismatched power supplies.
- 
- CAUTION:** To prevent improper cooling and thermal damage, do not operate the server unless all bays are populated with either a component or a blank.
- 

To install the component:

1. Access the product rear panel (on page 28).
2. Remove the blank.

- 
- WARNING:** To reduce the risk of personal injury from hot surfaces, allow the power supply or power supply blank to cool before touching it.
-

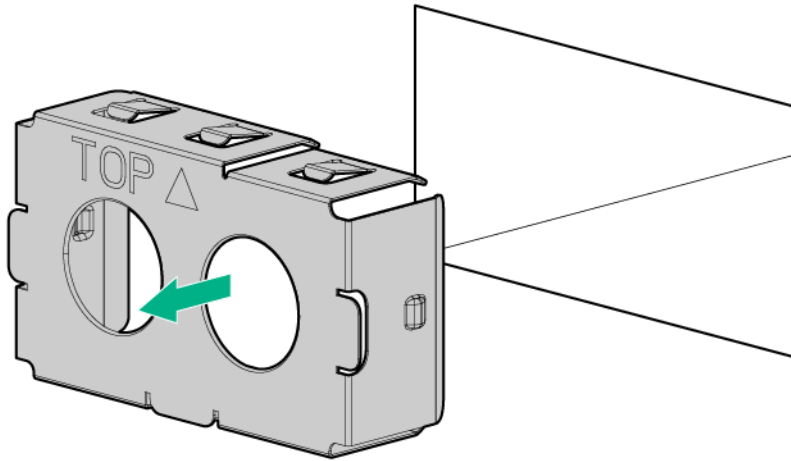

3. Insert the power supply into the power supply bay until it clicks into place.

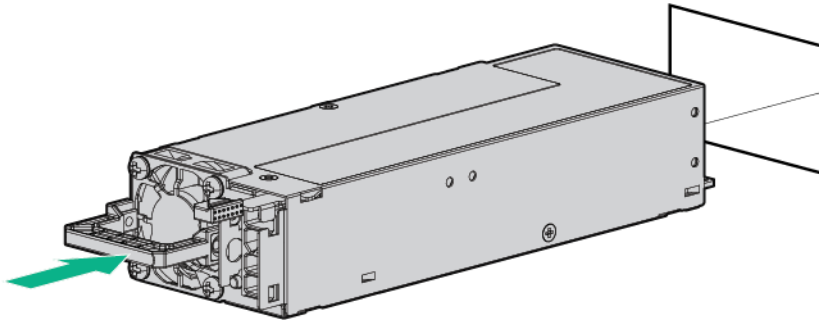

4. Connect the power cord to the power supply.
5. Route the power cord. Use best practices when routing power cords and other cables. A cable management arm is available to help with routing. To obtain a cable management arm, contact a Hewlett Packard Enterprise authorized reseller.
6. Connect the power cord to the AC power source.
7. Be sure that the power supply LED is green ("[Rear panel LEDs](#)" on page [14](#)).

## High-performance fan option

To install the component:

1. Power down the server (on page [26](#)).
2. Remove all power:
  - a. Disconnect each power cord from the power source.
  - b. Disconnect each power cord from the server.
3. Do one of the following:
  - o Extend the server from the rack (on page [26](#)).
  - o Remove the server from the rack (on page [27](#)).



4. Remove the access panel (on page 27).



**IMPORTANT:** Do not mix standard fans and high-performance fans in the same server.

5. Remove fan blanks and standard fans from all locations:

- o Fan blanks

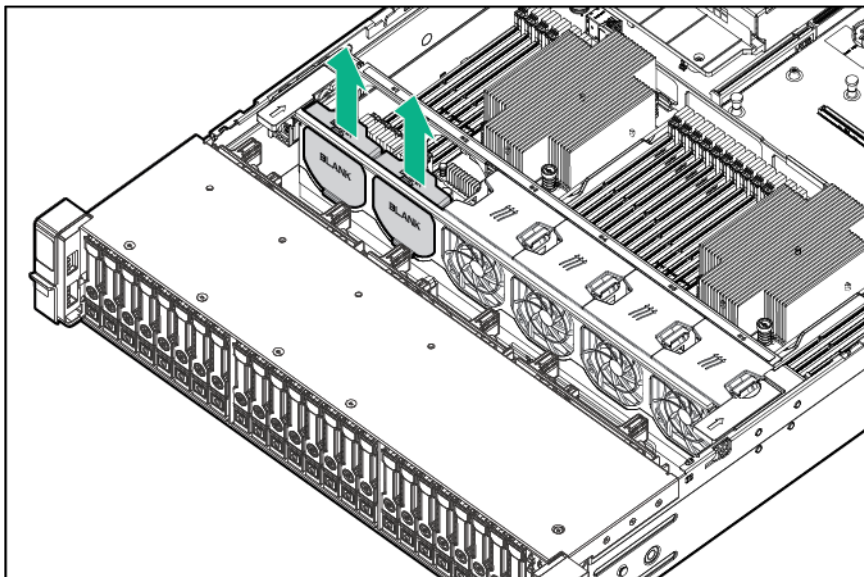

- o Standard fans

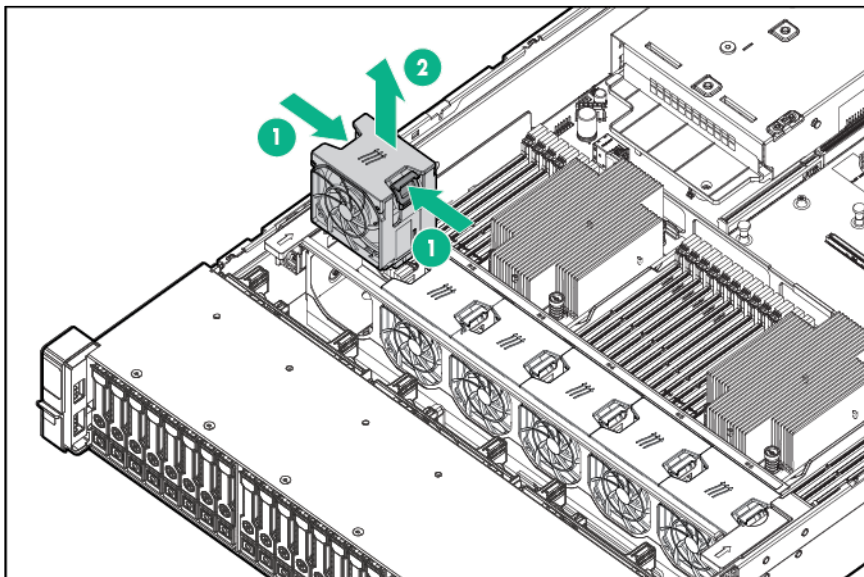

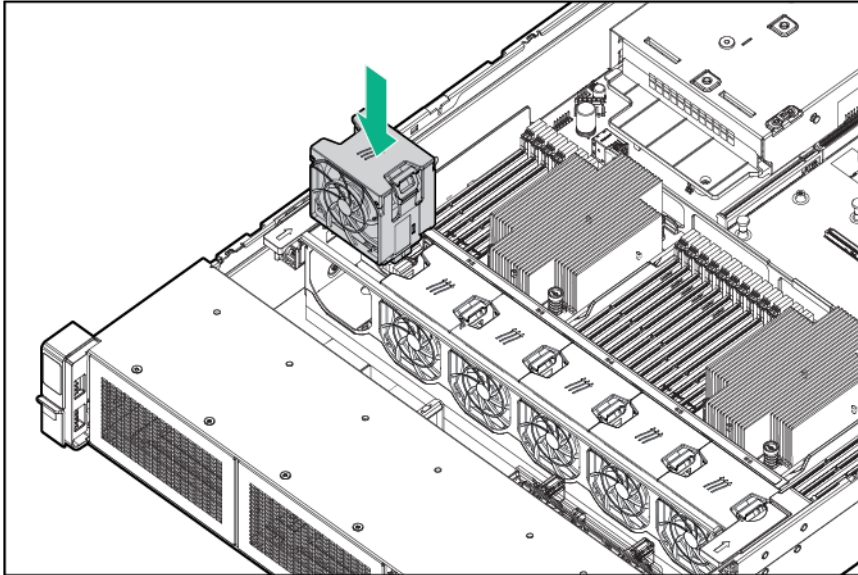

6. Install high-performance fans in all locations.



7. Install the access panel (on page 28).
8. Slide the server into the rack.
9. Connect each power cord to the server.
10. Connect each power cord to the power source.
11. Power up the server ("Powering up the server" on page 26).

## Processor and fan option

The server supports single-processor and dual-processor operations.

-  **CAUTION:** To avoid damage to the processor and system board, only authorized personnel should attempt to replace or install the processor in this server.
-  **CAUTION:** To prevent possible server malfunction and damage to the equipment, multiprocessor configurations must contain processors with the same part number.
-  **IMPORTANT:** If installing a processor with a faster speed, update the system ROM before installing the processor.

To install a processor:

1. Power down the server (on page 26).
2. Remove all power:
  - a. Disconnect each power cord from the power source.
  - b. Disconnect each power cord from the server.
3. Do one of the following:
  - o Extend the server from the rack (on page 26).
  - o Remove the server from the rack (on page 27).
4. Remove the access panel (on page 27).
5. Remove the air baffle (on page 32).
6. Remove the processor blank.

7. Open each of the processor locking levers in the order indicated in the following illustration, and then open the processor retaining bracket.

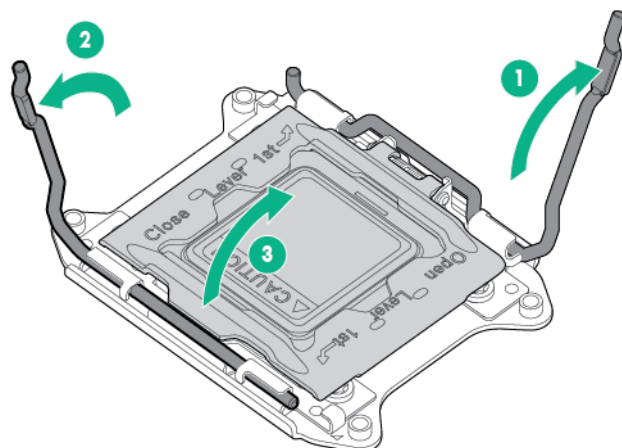

8. Remove the clear processor socket cover. Retain the processor socket cover for future use.

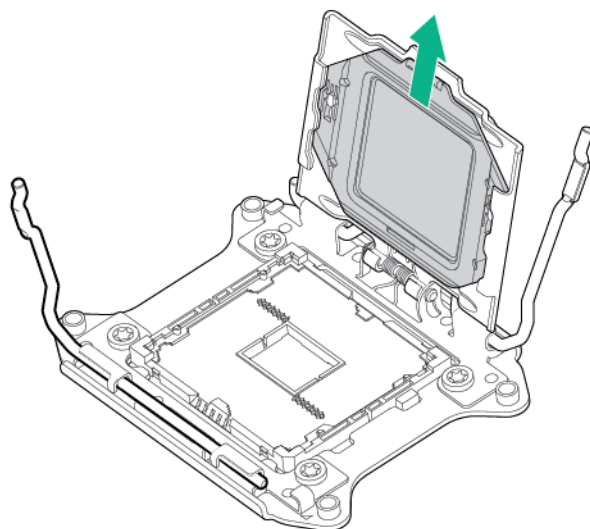

**CAUTION: THE PINS ON THE SYSTEM BOARD ARE VERY FRAGILE AND EASILY DAMAGED.** To avoid damage to the system board, do not touch the processor or the processor socket contacts.

9. Install the processor. Verify that the processor is fully seated in the processor retaining bracket by visually inspecting the processor installation guides on either side of the processor. **THE PINS ON THE SYSTEM BOARD ARE VERY FRAGILE AND EASILY DAMAGED.**

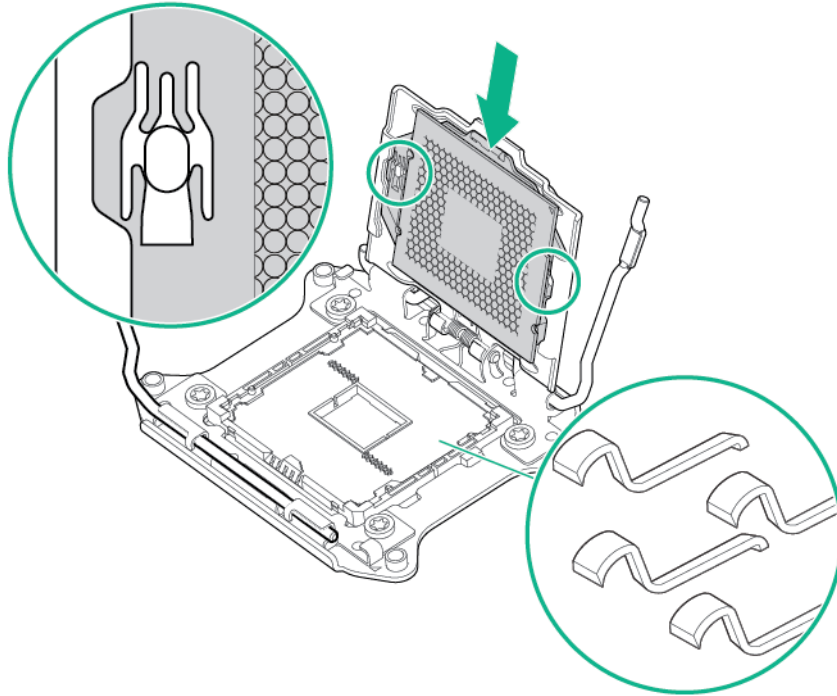

10. Close the processor retaining bracket. When the processor is installed properly inside the processor retaining bracket, the processor retaining bracket clears the flange on the front of the socket.

**CAUTION:** Do not press down on the processor. Pressing down on the processor may cause damage to the processor socket and the system board. Press only in the area indicated on the processor retaining bracket.

**CAUTION:** Close and hold down the processor cover socket while closing the processor locking levers. The levers should close without resistance. Forcing the levers closed can damage the processor and socket, requiring system board replacement.

11. Press and hold the processor retaining bracket in place, and then close each processor locking lever. Press only in the area indicated on the processor retaining bracket.

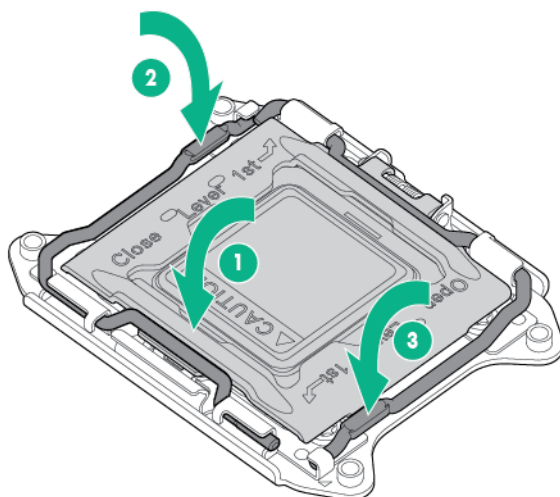

---

⚠ **CAUTION:** Close and hold down the processor cover socket while closing the processor locking levers. The levers should close without resistance. Forcing the levers closed can damage the processor and socket, requiring system board replacement.

---

12. Remove the heatsink cover.

⚠ **CAUTION:** After the cover is removed, do not touch the thermal interface media.

---

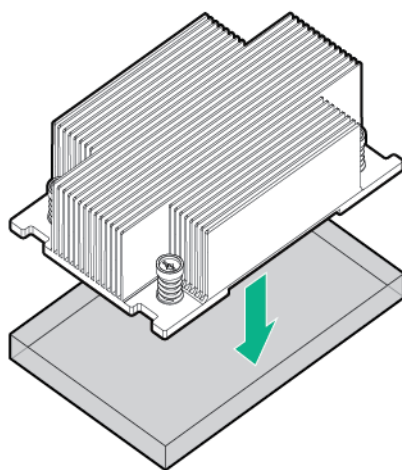

13. Install the heatsink:
  - a. Position the heatsink on the processor backplate.
  - b. Tighten one pair of diagonally opposite screws halfway, and then tighten the other pair of screws.

- c. Finish the installation by completely tightening the screws in the same sequence.

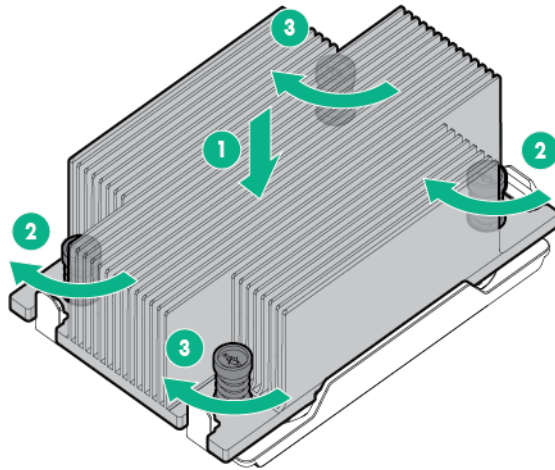

14. Remove the fan blanks from locations 1 and 2. For fan location and numbering information, see "Hot-plug fans (on page 23)" or the label attached to the chassis next to the fans.

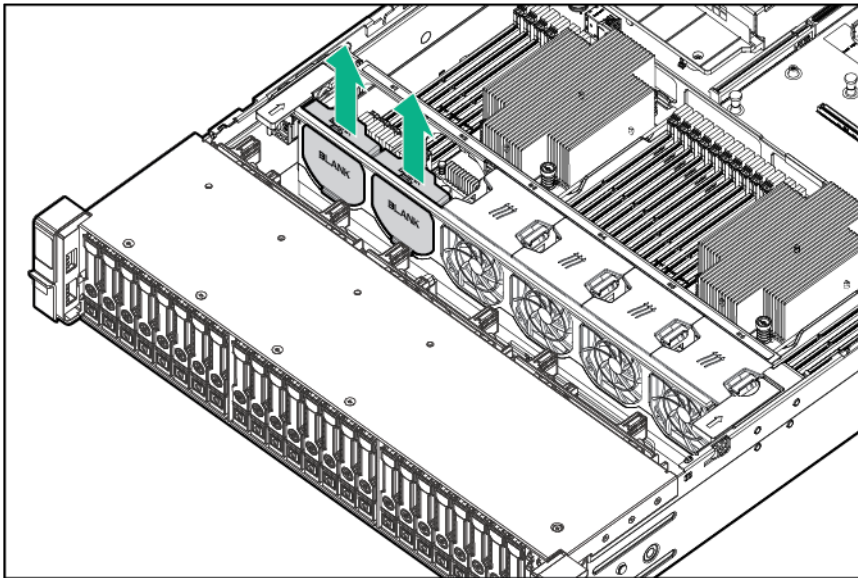

15. Install the fans into locations 1 and 2.

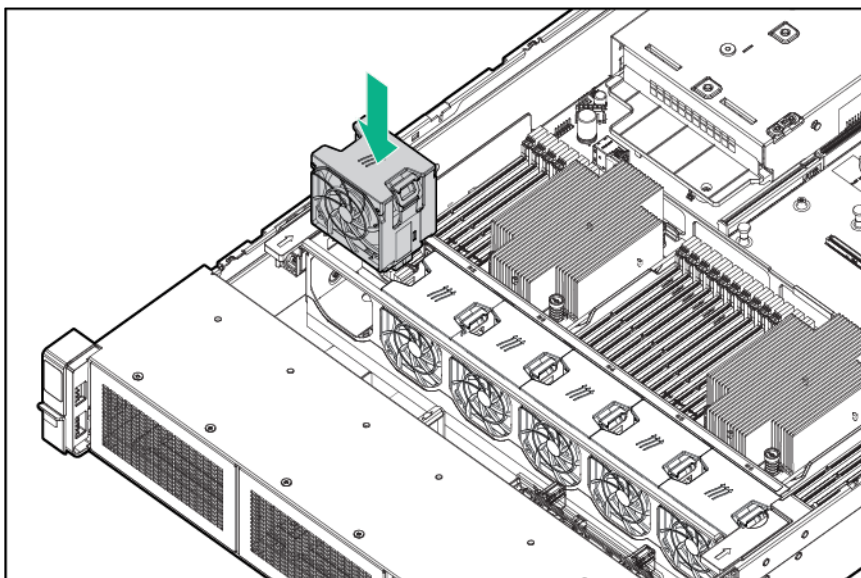

16. Install the air baffle (on page 33).
17. Install the access panel (on page 28).
18. Install the server into the rack.
19. Connect each power cord to the server.
20. Connect each power cord to the power source.
21. Press the Power On/Standby button.

The server exits standby mode and applies full power to the system. The system power LED changes from amber to green.

## Memory options



**IMPORTANT:** This server does not support mixing LRDIMMs and RDIMMs. Attempting to mix any combination of these DIMMs can cause the server to halt during BIOS initialization.

The memory subsystem in this server can support LRDIMMs or RDIMMs:

- RDIMMs offer address parity protection.
- LRDIMMs support higher densities than single-rank and dual-rank RDIMMs. This support enables you to install higher capacity DIMMs, resulting in higher system capacities and higher bandwidth.

All types are referred to as DIMMs when the information applies to all types. When specified as LRDIMM or RDIMM, the information applies to that type only. All memory installed in the server must be of the same type.

## Memory-processor compatibility information

The server processor determines the type of DIMM that will be supported in the server.

For the latest memory configuration information, see the product QuickSpecs on the Hewlett Packard Enterprise website (<http://www.hpe.com/info/qs>).

### DIMM type

- Intel Xeon E5-2600 v3 processors support:
  - Single-rank and dual-rank PC4-2133P (DDR4-2133) RDIMMs operating at up to 2133 MT/s

- Dual- and quad-rank PC4-2133P (DDR4-2133) LRDIMMs operating at up to 2133 MT/s
- Intel Xeon E5-2600 v4 processors support:
  - Single-rank and dual-rank PC4-2400T (DDR4-2400) RDIMMs operating at up to 2400 MT/s
  - Dual-rank and quad-rank PC4-2400T (DDR4-2400) LRDIMMs operating at up to 2400 MT/s
  - Octal-rank PC4-2400U (DDR4-2400) LRDIMMs operating at up to 2400 MT/s

### DIMM specifications

DIMM specifications - Intel Xeon E5-2600 v3 processor installed

Type	Rank	Capacity (GB)	Native speed (MT/s)	Voltage
RDIMM	Single	4 or 8	2133	STD
RDIMM	Dual	8, 16, or 32	2133	STD
LRDIMM	Dual	16	2133	STD
LRDIMM	Quad	32 or 64	2133	STD

DIMM specifications - Intel Xeon E5-2600 v4 processor installed

Type	Rank	Capacity (GB)	Native speed (MT/s)	Voltage
RDIMM	Single	8 or 16	2400	STD
RDIMM	Dual	16 or 32	2400	STD
LRDIMM	Dual	32	2400	STD
LRDIMM	Quad	64	2400	STD
LRDIMM	Octal	128	2400	STD

### Populated DIMM speed (MT/s)

Populated DIMM speed - Intel Xeon E5-2600 v3 processor installed

Type	Rank	Capacity (GB)	1 DIMM per channel (MT/s)	2 DIMMs per channel (MT/s)	3 DIMMs per channel (MT/s)
RDIMM	Single	4 or 8	2133	2133	1600
RDIMM	Dual	8, 16, or 32	2133	2133	1600
LRDIMM	Dual	16	2133	2133	1866
LRDIMM	Quad	32 or 64	2133	2133	1866

Populated DIMM speed - Intel Xeon E5-2600 v4 processor installed

Type	Rank	Capacity (GB)	1 DIMM per channel (MT/s)	2 DIMMs per channel (MT/s)	3 DIMMs per channel (MT/s)
RDIMM	Single	8 or 16	2400	2400	1866
RDIMM	Dual	16 or 32	2400	2400	1866
LRDIMM	Dual	32	2400	2400	2400
LRDIMM	Quad	64	2400	2400	2400
LRDIMM	Octal	128	2400	2400	2400

The operating memory speed is a function of the rated DIMM speed, DIMMs installed per channel, processor model, and the speed selected in the BIOS/Platform Configuration (RBSU) of the UEFI System Utilities.

Depending on the processor model, the number of DIMMs installed, and whether LRDIMMs or RDIMMs are installed, the memory clock speed can be reduced to 1866 MT/s.



## Maximum memory capacity

The maximum memory capacity is a function of the DIMM capacity, number of installed DIMMs, memory type, and number of installed processors.

Maximum memory capacity - Intel Xeon E5-2600 v3 processor installed

DIMM type	DIMM rank	Capacity (GB)	One processor (GB)	Two processors (GB)
RDIMM	Single	4	48	96
RDIMM	Single	8	96	192
RDIMM	Dual	8	96	192
RDIMM	Dual	16	192	384
RDIMM	Dual	32	384	768
LRDIMM	Dual	16	192	384
LRDIMM	Dual	32	384	768
LRDIMM	Quad	64	768	1536

Maximum memory capacity - Intel Xeon E5-2600 v4 processor installed

DIMM type	DIMM rank	Capacity (GB)	One processor (GB)	Two processors (GB)
RDIMM	Single	8	96	192
RDIMM	Single	16	192	384
RDIMM	Dual	16	192	384
RDIMM	Dual	32	384	768
LRDIMM	Dual	32	384	768
LRDIMM	Quad	64	768	1536
LRDIMM	Octal	128	1536	3072

For the latest memory configuration information, see the QuickSpecs on the Hewlett Packard Enterprise website (<http://www.hpe.com/info/qs>).

## SmartMemory

HPE SmartMemory has the capability to operate at higher operational speeds than originally designed for, actually exceeding the industry standard when installed in HPE ProLiant servers.

It utilizes proprietary software that simulates varied and extreme operating environments and conditions is used to unlock certain performance and high-efficiency features optimized for HPE ProLiant servers. HPE SmartMemory is equipped with advanced error detection technology monitors memory parameters to find defects that can cause performance degradation or significantly increase the probability of a non-recoverable memory condition. The power consumption rate of SmartMemory is up to 20 percent less compared to third-party memory or other OEMs' memory.

## Memory subsystem architecture

The memory subsystem in this server is divided into channels. Each processor supports four channels, and each channel supports three DIMM slots, as shown in the following table.

Channel	Population order	Slot number
1	A	12
	E	11
	I	10
2	B	9
	F	8
	J	7

Channel	Population order	Slot number
3	C	1
	G	2
	K	3
4	D	4
	H	5
	L	6

For the location of the slot numbers, see "DIMM slot locations (on page 19)."

This multi-channel architecture provides enhanced performance in Advanced ECC mode. This architecture also enables Online Spare Memory mode.

DIMM slots in this server are identified by number and by letter. Letters identify the population order. Slot numbers indicate the DIMM slot ID for spare replacement.

## DIMM ranks

To understand and configure memory protection modes properly, an understanding of DIMM rank is helpful. Some DIMM configuration requirements are based on these classifications.

A single-rank DIMM has one set of memory chips that is accessed while writing to or reading from the memory. A dual-rank DIMM is similar to having two single-rank DIMMs on the same module, with only one rank accessible at a time. A quad-rank DIMM is, effectively, two dual-rank DIMMs on the same module. Only one rank is accessible at a time. The server memory control subsystem selects the proper rank within the DIMM when writing to or reading from the DIMM.

Dual- and quad-rank DIMMs provide the greatest capacity with the existing memory technology. For example, if current DRAM technology supports 8-GB single-rank DIMMs, a dual-rank DIMM would be 16 GB, and a quad-rank DIMM would be 32 GB, and an octal-rank LRDIMM would be 64 GB.

LRDIMMs are labeled as quad- and octal-rank DIMMs. There are four and eight ranks of DRAM on the DIMM, but the LRDIMM buffer creates an abstraction that allows the DIMM to appear as a logical dual-rank DIMM to the system. This is called Rank Multiplication. The LRDIMM buffer also isolates the electrical loading of the DRAM from the system to allow for faster operation. These two changes allow the system to support up to three LRDIMMs per memory channel, providing for greater memory capacity and higher memory operating speed compared to quad-rank RDIMMs.

## DIMM identification

To determine DIMM characteristics, see the label attached to the DIMM and refer to the following illustration and table.

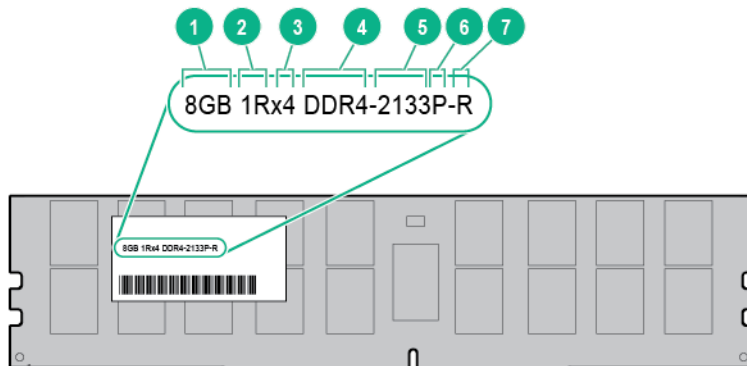

Item	Description	Definition
1	Capacity	8 GB 16 GB 32 GB 64 GB 128 GB
2	Rank	1R = Single-rank 2R = Dual-rank 4R = Quad-rank 8R = Octal-rank
3	Data width on DRAM	x4 = 4-bit x8 = 8-bit
4	Memory generation	DDR4
5	Maximum memory speed	2133 MT/s 2400 MT/s
6	CAS latency	P=15-15-15 T=17-17-17 U=20-18-18
7	DIMM type	R = RDIMM (registered) L = LRDIMM (load reduced)

For more information about product features, specifications, options, configurations, and compatibility, see the product QuickSpecs on the Hewlett Packard Enterprise website (<http://www.hpe.com/info/qs>).

## Memory configurations

To optimize server availability, the server supports the following AMP modes:

- **Advanced ECC**—Provides up to 4-bit error correction. This mode is the default option for this server.
- **Online spare memory**—Provides protection against failing or degraded DIMMs. Certain memory is reserved as spare, and automatic failover to spare memory occurs when the system detects a DIMM that is degrading. This allows DIMMs that have a higher probability of receiving an uncorrectable memory error (which would result in system downtime) to be removed from operation.
- **Mirrored memory**—Provides maximum protection against failed DIMMs. Uncorrectable errors in one channel are corrected by the mirror channel.

Advanced Memory Protection options are configured in the BIOS/Platform Configuration (RBSU). If the requested AMP mode is not supported by the installed DIMM configuration, the server boots in Advanced ECC mode. For more information, see the *HPE UEFI System Utilities User Guide for HPE ProLiant Gen9 Servers* on the Hewlett Packard Enterprise website (<http://www.hpe.com/info/ProLiantUEFI/docs>).

## Advanced ECC memory configuration

Advanced ECC memory is the default memory protection mode for this server. Standard ECC can correct single-bit memory errors and detect multi-bit memory errors. When multi-bit errors are detected using Standard ECC, the error is signaled to the server and causes the server to halt.

Advanced ECC protects the server against some multi-bit memory errors. Advanced ECC can correct both single-bit memory errors and 4-bit memory errors if all failed bits are on the same DRAM device on the DIMM.

Advanced ECC provides additional protection over Standard ECC because it is possible to correct certain memory errors that would otherwise be uncorrected and result in a server failure. Using HPE Advanced Memory Error Detection technology, the server provides notification when a DIMM is degrading and has a higher probability of uncorrectable memory error.

## Online Spare memory configuration

Online spare memory provides protection against degraded DIMMs by reducing the likelihood of uncorrected memory errors. This protection is available without any operating system support.

Online spare memory protection dedicates one rank of each memory channel for use as spare memory. The remaining ranks are available for OS and application use. If correctable memory errors occur at a rate higher than a specific threshold on any of the non-spare ranks, the server automatically copies the memory contents of the degraded rank to the online spare rank. The server then deactivates the failing rank and automatically switches over to the online spare rank.

## Mirrored memory configuration

Mirroring provides protection against uncorrected memory errors that would otherwise result in server downtime. Mirroring is performed at the channel level to one memory channel pair that can be either:

- Channel 1 data being mirrored in channel 2
- Channel 3 data being mirrored in channel 4

If an uncorrectable error is detected in the active memory channel, data is retrieved from the mirror channel. This channel becomes the new active channel, and the system disables the channel with the failed DIMM.

## General DIMM slot population guidelines

Observe the following guidelines for all AMP modes:

- Install DIMMs only if the corresponding processor is installed.
- When two processors are installed, balance the DIMMs across the two processors.
- White DIMM slots denote the first slot of a channel (Ch 1-A, Ch 2-B, Ch 3-C, Ch 4-D)
- Do not mix RDIMMs and LRDIMMs.
- When one processor is installed, install DIMMs in sequential alphabetic order: A, B, C, D, E, F, and so forth.
- When two processors are installed, install the DIMMs in sequential alphabetic order balanced between the two processors: P1-A, P2-A, P1-B, P2-B, P1-C, P2-C, and so forth.
- When single-rank, dual-rank, and quad-rank DIMMs are populated for two DIMMs per channel or three DIMMs per channel, always populate the higher number rank DIMM first (starting from the farthest slot). For example, first quad-rank DIMM, then dual-rank DIMM, and then lastly single-rank DIMM.
- DIMMs should be populated starting farthest from the processor on each channel.
- For DIMM spare replacement, install the DIMMs per slot number as instructed by the system software.

For more information about server memory, see the Hewlett Packard Enterprise website (<http://www.hpe.com/info/memory>).

## Advanced ECC population guidelines

For Advanced ECC mode configurations, observe the following guidelines:

- Observe the general DIMM slot population guidelines (on page 68).
- DIMMs may be installed individually.

## Online spare population guidelines

For Online Spare memory mode configurations, observe the following guidelines:

- Observe the general DIMM slot population guidelines (on page 68).
- Each channel must have a valid online spare configuration.
- Each channel can have a different valid online spare configuration.
- Each populated channel must have a spare rank. A single dual-rank DIMM is not a valid configuration.

## Population order

For memory configurations with a single processor or multiple processors, DIMMs must be populated sequentially in alphabetical order (A through L).

After installing the DIMMs, use the BIOS/Platform Configuration (RBSU) in the UEFI System Utilities to configure supported AMP modes.

## Mirrored Memory population guidelines

For Mirrored Memory mode configurations, observe the following guidelines:

- Observe the general DIMM slot population guidelines (on page 68).
- Install DIMMs in either channel 1 and channel 2, or channel 3 and channel 4. Installed DIMMs must be identical in terms of size and organization.
- In multi-processor configurations, each processor must have a valid Mirrored Memory configuration.

## Identifying the processor type

The processor type installed in the server is briefly displayed during POST. To view this information and additional processor specifications, do the following:

1. Reboot the server.  
The server restarts and the POST screen appears.
2. Press **F9**.  
The System Utilities screen appears.
3. Select **System Information | Processor Information**.  
The Processor Information screen shows detailed information about the processors installed in the server.
4. Press **Esc** until the main menu is displayed.
5. Select **Reboot the System** to exit the utility and resume the boot process.

## Installing a DIMM

The server supports up to 24 DIMMs.

To install a DIMM:

1. Power down the server (on page 26).
2. Remove all power:
  - a. Disconnect each power cord from the power source.
  - b. Disconnect each power cord from the server.
3. Do one of the following:

- Extend the server from the rack (on page 26).
- Remove the server from the rack (on page 27).
- 4. Remove the access panel (on page 27).
- 5. Remove the air baffle (on page 32).
- 6. Open the DIMM slot latches.
- 7. Install the DIMM.

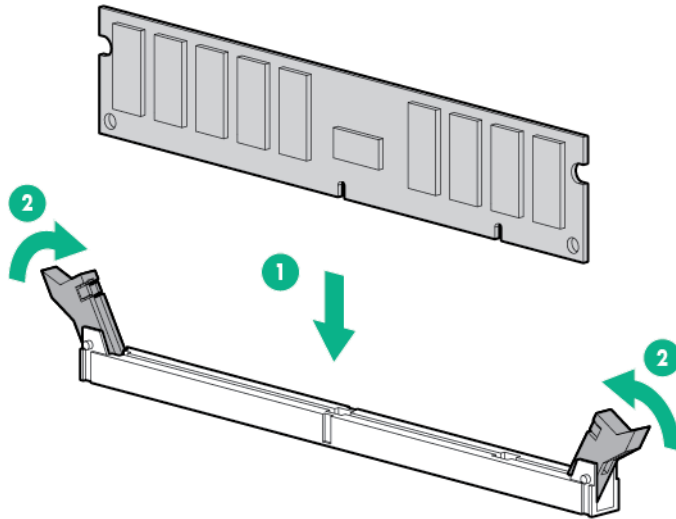

- 8. Install the air baffle (on page 33).
- 9. Install the access panel (on page 28).
- 10. Install the server into the rack ("Installing the server into the rack" on page 39).
- 11. Connect each power cord to the server.
- 12. Connect each power cord to the power source.
- 13. Power up the server ("Powering up the server" on page 26).

Use the BIOS/Platform Configuration (RBSU) in the UEFI System Utilities to configure the memory mode.

For more information about LEDs and troubleshooting failed DIMMs, see "Systems Insight Display LED combinations (on page 13)."

## Universal media bay option

The following procedure provides the steps to install the universal media bay option, route the VGA and USB cables, and install an optional optical disk drive. The universal media bay option also accommodates the two-bay SFF front drive cage option. For information on installing this option, see "Two-bay SFF front drive cage option (on page 94)."

- 1. Power down the server (on page 26).
- 2. Remove all power:
  - a. Disconnect each power cord from the power source.
  - b. Disconnect each power cord from the server.
- 3. Do one of the following:
  - Extend the server from the rack (on page 26).
  - Remove the server from the rack (on page 27).
- 4. Remove the access panel (on page 27).

5. Remove the air baffle (on page 32).
6. Remove the fan cage (on page 29).
7. Remove the bay blank.

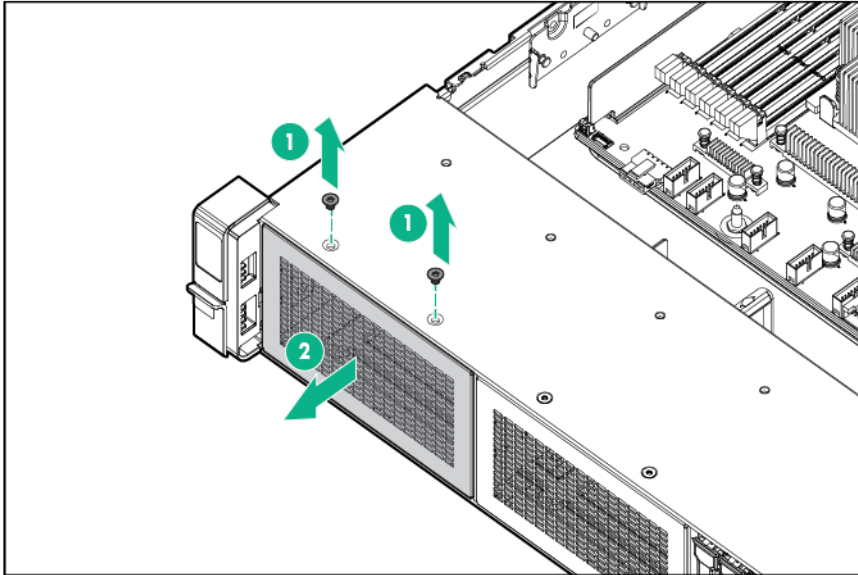

8. Route the USB/VGA cables through the opening, and then install the universal media bay.

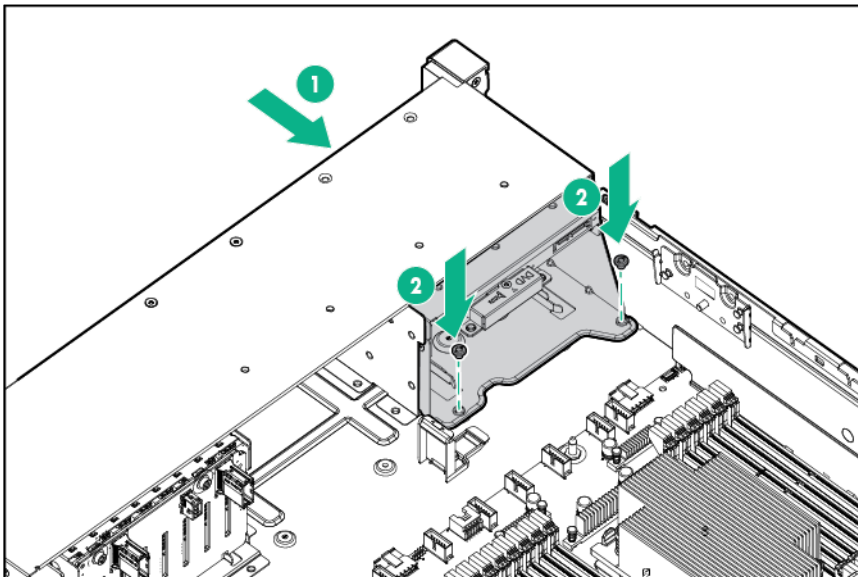

9. Install the optional optical disk drive (optional).

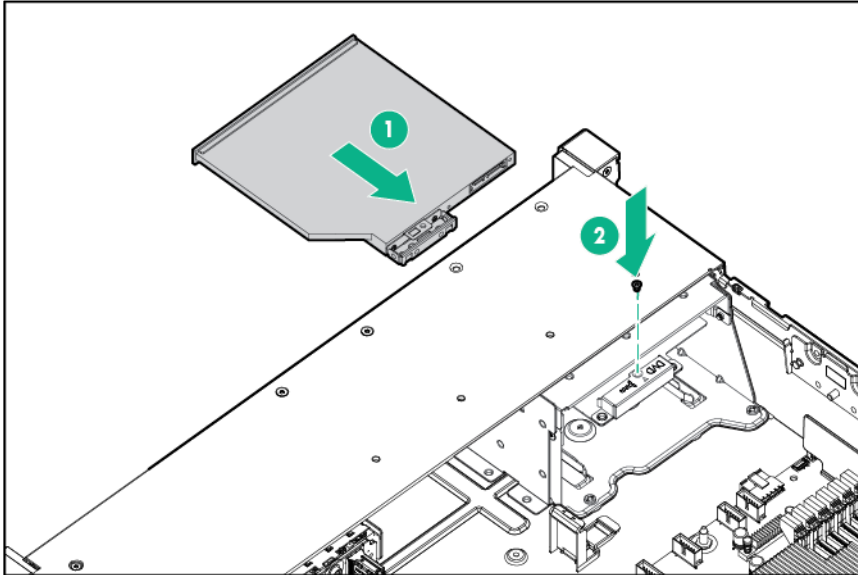

10. Connect the cables:

- o Connect the VGA cable to the optional VGA connector. Connect the USB cable to the front dual internal USB 3.0 connector.

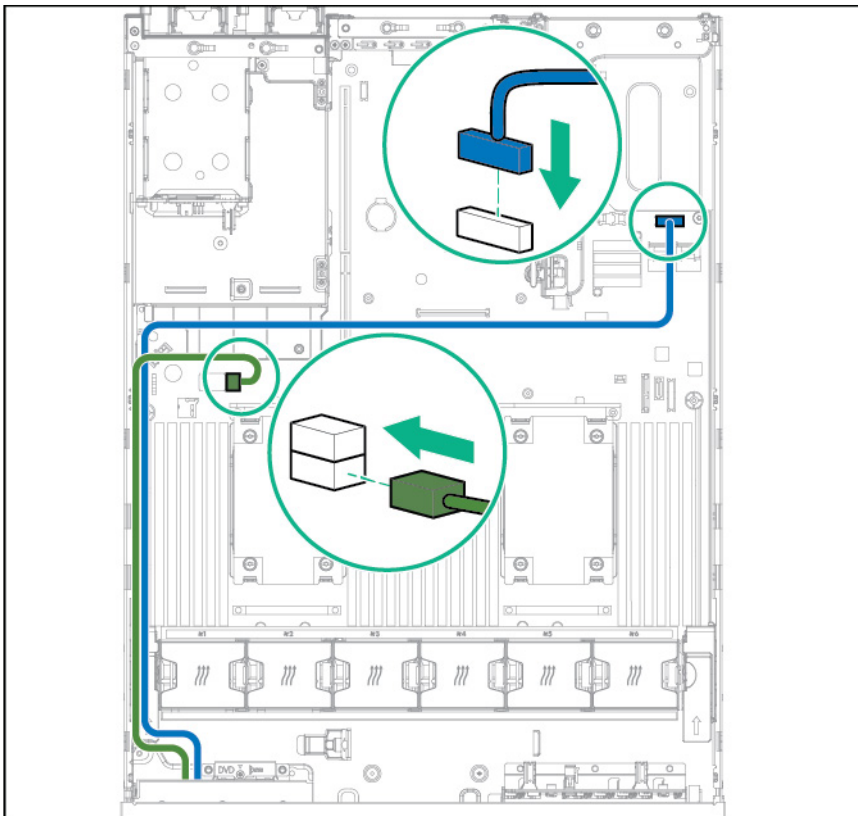



- Connect the SATA optical drive cable to the front optical disk drive connector (optional).

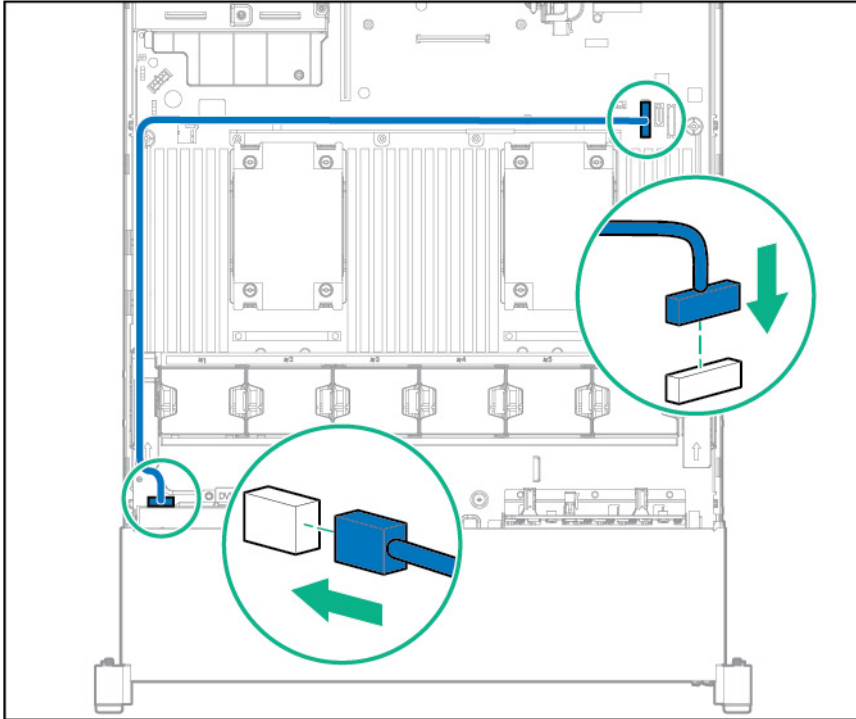

11. Install the fan cage.
12. Install the air baffle (on page 33).
13. Install the access panel (on page 28).
14. Slide the server into the rack.
15. Connect each power cord to the server.
16. Connect each power cord to the power source.
17. Power up the server ("Powering up the server" on page 26).

## 2-slot PCI riser cage option

**⚠ WARNING:** To reduce the risk of personal injury, electric shock, or damage to the equipment, remove the power cord to remove power from the server. The front panel Power On/Standby button does not completely shut off system power. Portions of the power supply and some internal circuitry remain active until AC power is removed.

**⚠ CAUTION:** To prevent improper cooling and thermal damage, do not operate the server unless all PCI slots have either an expansion slot cover or an expansion board installed.

To install the component:

1. Power down the server (on page 26).
2. Remove all power:
  - a. Disconnect each power cord from the power source.
  - b. Disconnect each power cord from the server.
3. Do one of the following:
  - Extend the server from the rack (on page 26).
  - Remove the server from the rack (on page 27).

4. Remove the access panel (on page 27).
5. Remove the standard PCI riser from the primary slot.

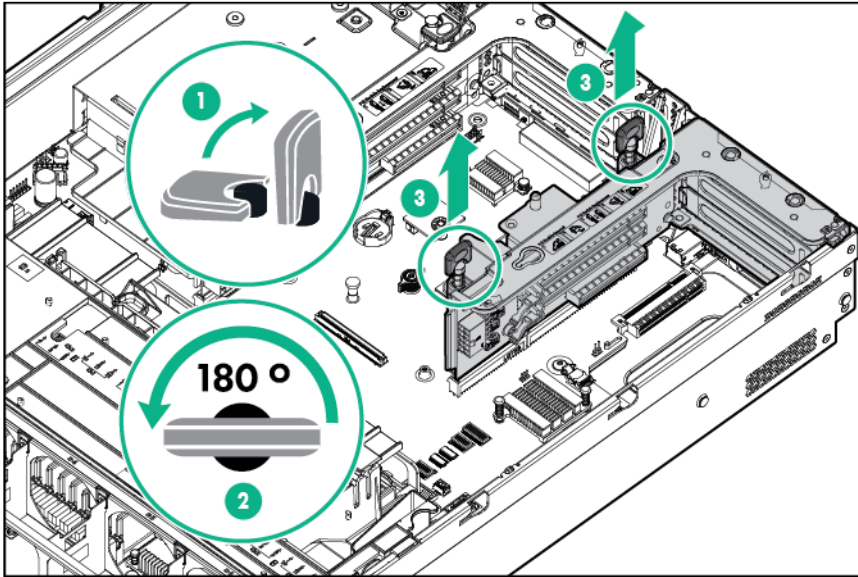

6. Remove the blank from the optional 2-slot PCI riser cage.

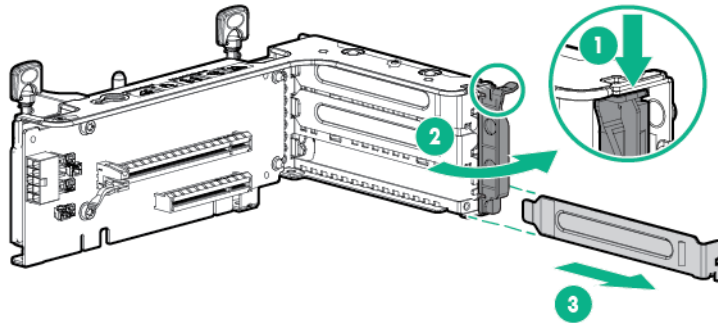

7. Install an optional expansion board into the PCI riser cage.

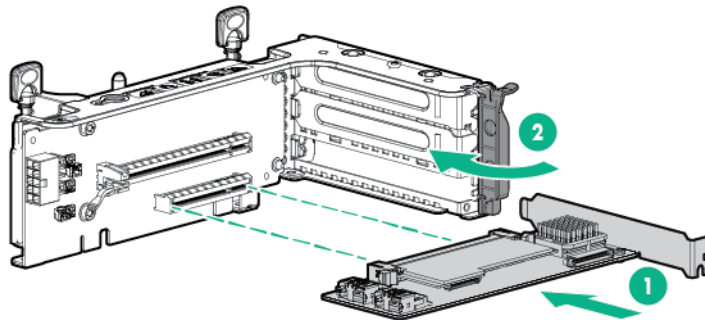

8. Install the optional 2-slot PCI riser cage.

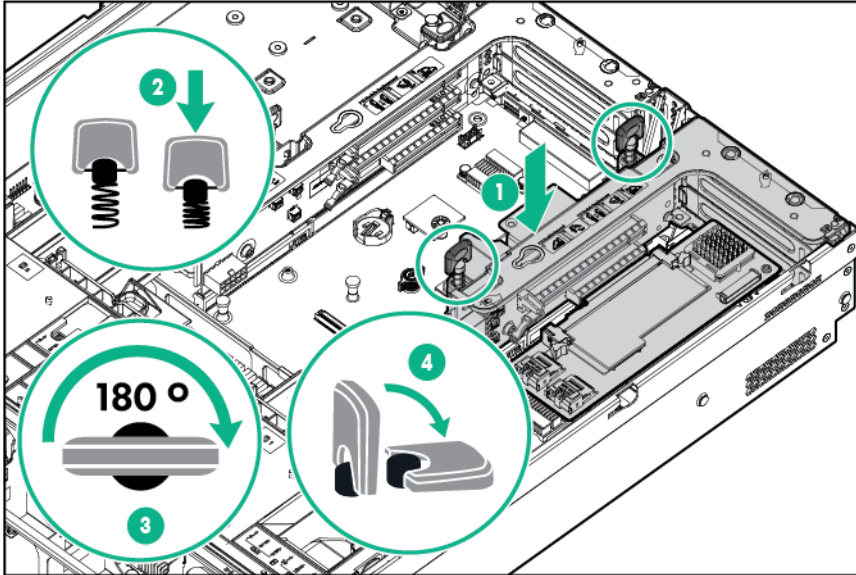

9. Connect any required internal or external cables to the expansion board. See the documentation that ships with the expansion board.
10. Install the access panel (on page 28).
11. Slide the server into the rack.
12. Connect each power cord to the server.
13. Connect each power cord to the power source.
14. Power up the server ("[Powering up the server](#)" on page 26).

## 3-slot PCI riser cage option

**WARNING:** To reduce the risk of personal injury, electric shock, or damage to the equipment, remove the power cord to remove power from the server. The front panel Power On/Standby button does not completely shut off system power. Portions of the power supply and some internal circuitry remain active until AC power is removed.

**CAUTION:** To prevent improper cooling and thermal damage, do not operate the server unless all PCI slots have either an expansion slot cover or an expansion board installed.

To install the component:

1. Power down the server (on page 26).
2. Remove all power:
  - a. Disconnect each power cord from the power source.
  - b. Disconnect each power cord from the server.
3. Do one of the following:
  - o Extend the server from the rack (on page 26).
  - o Remove the server from the rack (on page 27).
4. Remove the access panel (on page 27).

5. Remove the secondary PCI riser blank. Some models might require removing only two screws.

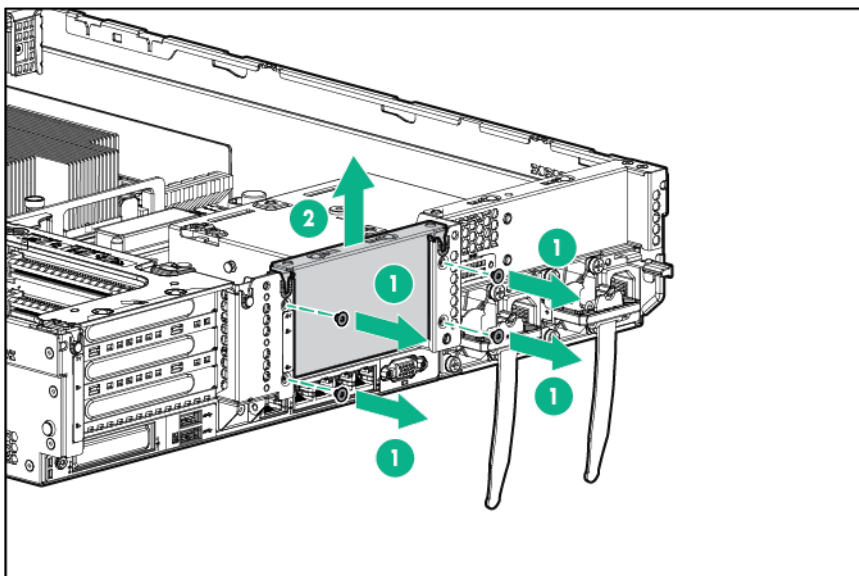

6. Remove the blank from the optional 3-slot PCI riser cage.

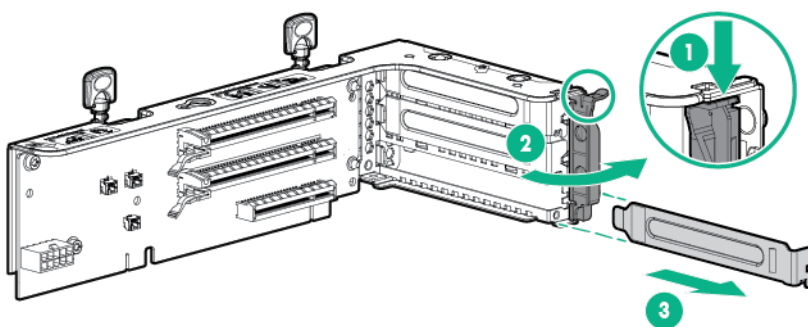

7. Install an expansion board into the PCI riser cage.

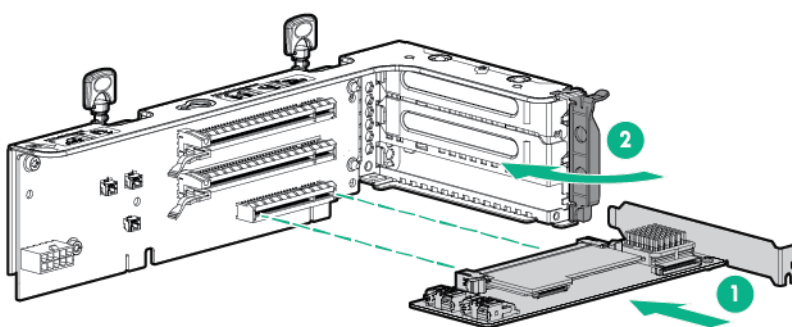

8. Install the optional 3-slot PCI riser cage.

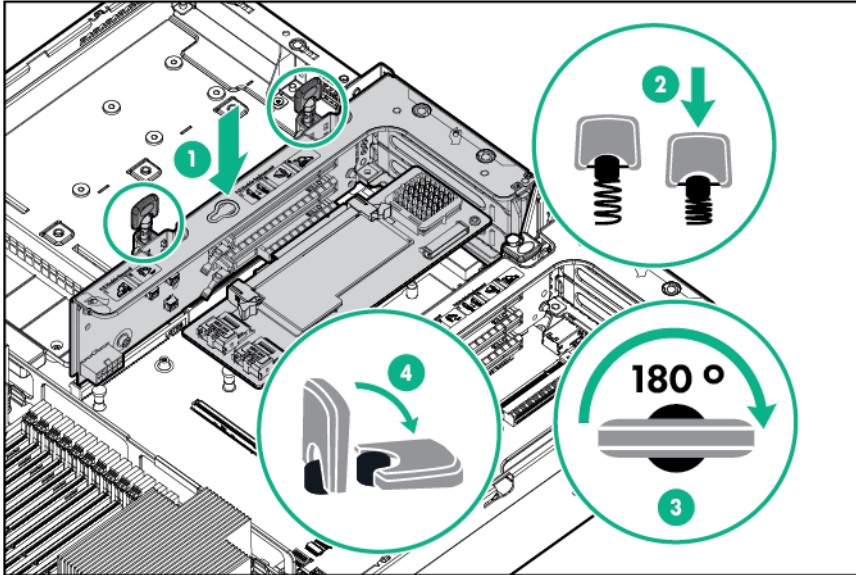

9. Install the access panel (on page 28).
10. Slide the server into the rack.
11. Connect each power cord to the server.
12. Connect each power cord to the power source.
13. Power up the server ("Powering up the server" on page 26).

## GPU enablement kit

**⚠ WARNING:** To reduce the risk of personal injury, electric shock, or damage to the equipment, remove the power cord to remove power from the server. The front panel Power On/Standby button does not completely shut off system power. Portions of the power supply and some internal circuitry remain active until AC power is removed.

**⚠ CAUTION:** To prevent improper cooling and thermal damage, do not operate the server unless all PCI slots have either an expansion slot cover or an expansion board installed.

To install the component:

1. Power down the server (on page 26).
2. Remove all power:
  - a. Disconnect each power cord from the power source.
  - b. Disconnect each power cord from the server.
3. Do one of the following:
  - o Extend the server from the rack (on page 26).
  - o Remove the server from the rack (on page 27).
4. Remove the access panel (on page 27).
5. Remove the air baffle (on page 32).

6. Remove the standard efficiency air diverters from the air baffle.

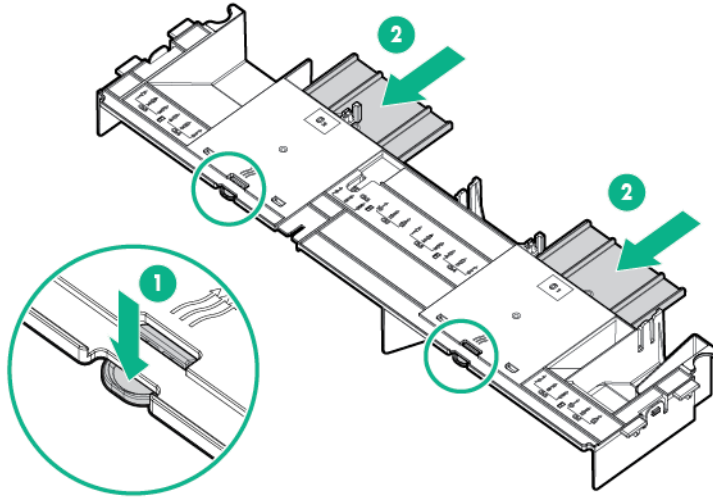

7. Install the GPU retention clips onto the air baffle.

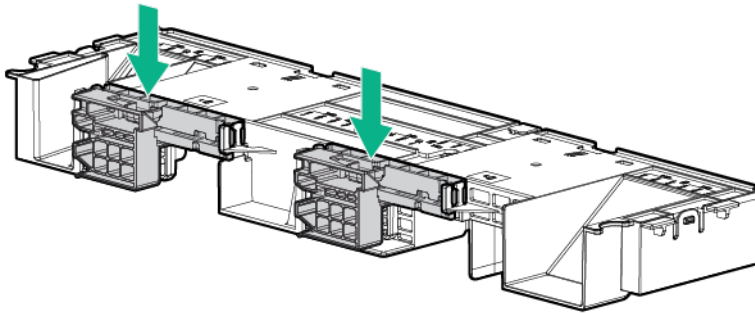

8. Remove the standard heatsinks.

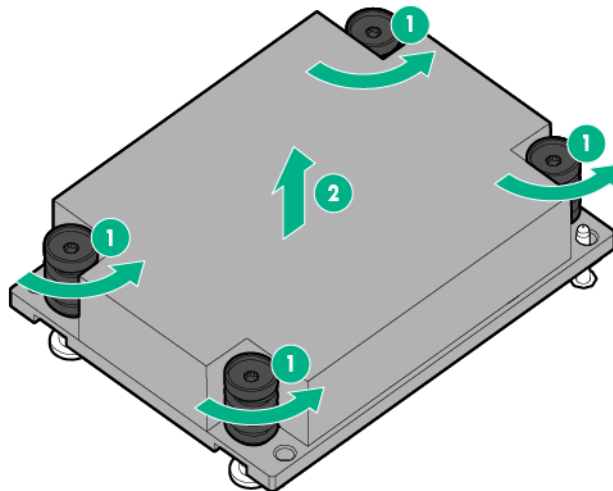

9. Install the high-performance heatsinks.

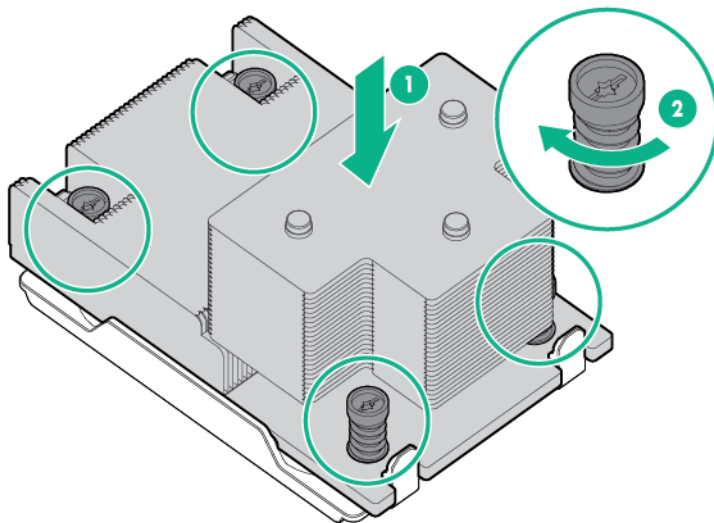

10. Install the air baffle.

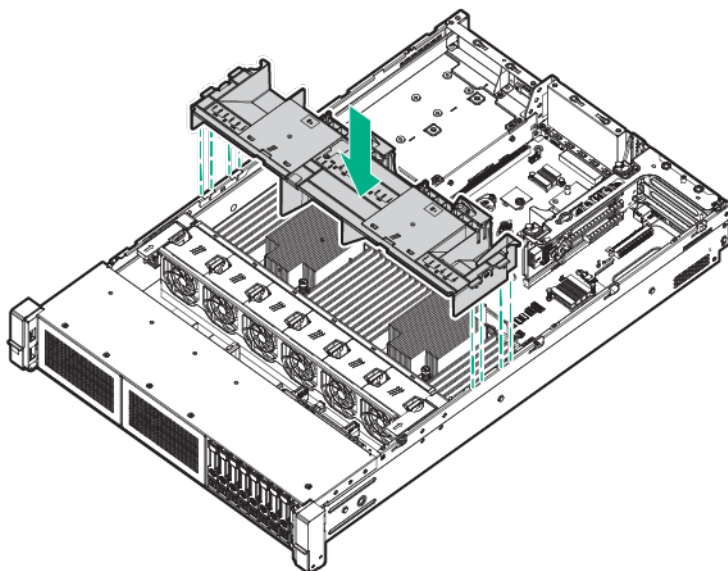

**IMPORTANT:** This server supports GPU riser cages in both the primary and secondary riser locations. This document shows installation into the secondary riser location.

11. Remove the secondary PCI riser blank. Some models might require removing more than two screws.

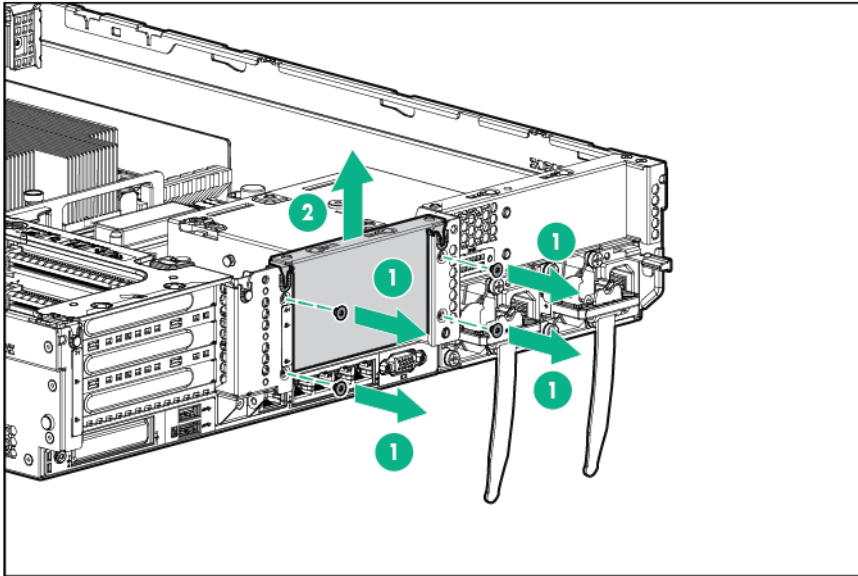

12. Install a GPU into the optional GPU-enabled riser cage.

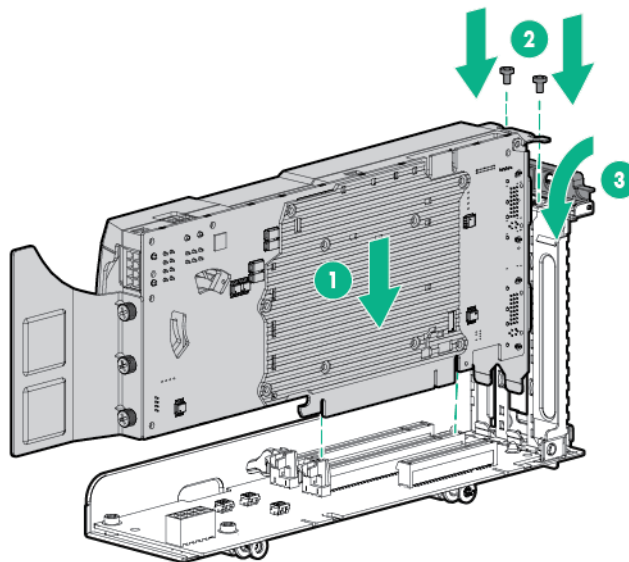



13. Connect the power cable.

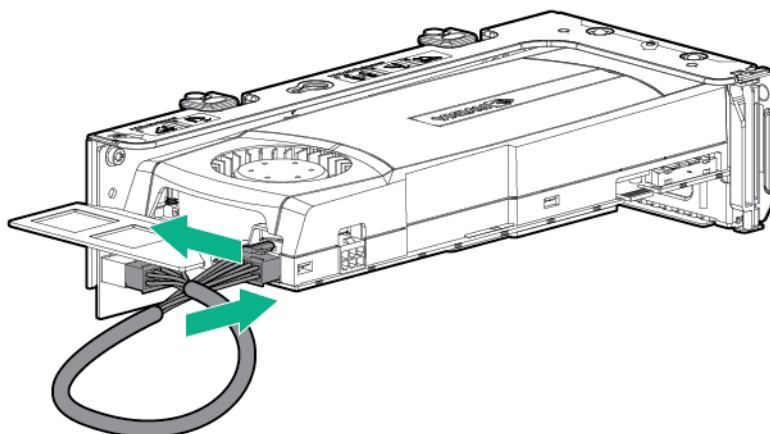

14. Press down on the top of the retention clips and slide them to the unlocked position.

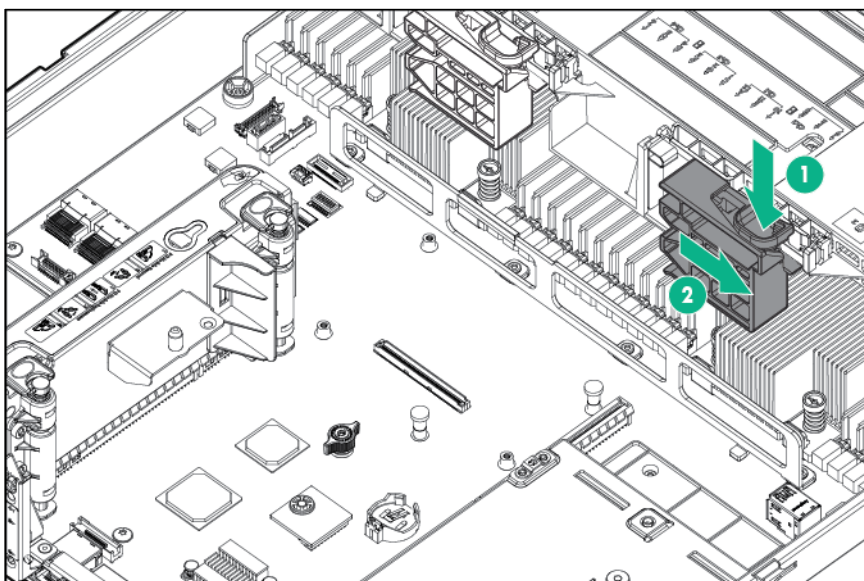

15. Install the GPU-enabled riser cage option.

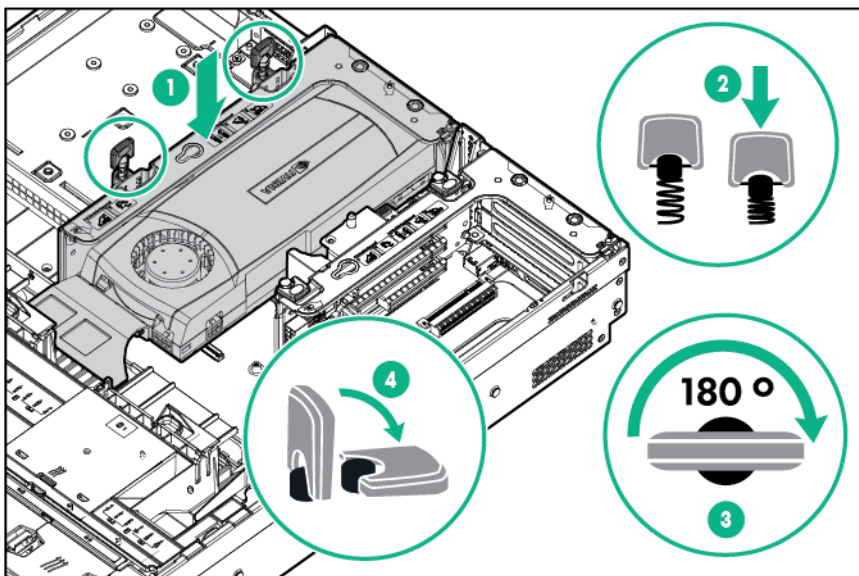

16. Slide the retention clips to the locked position.

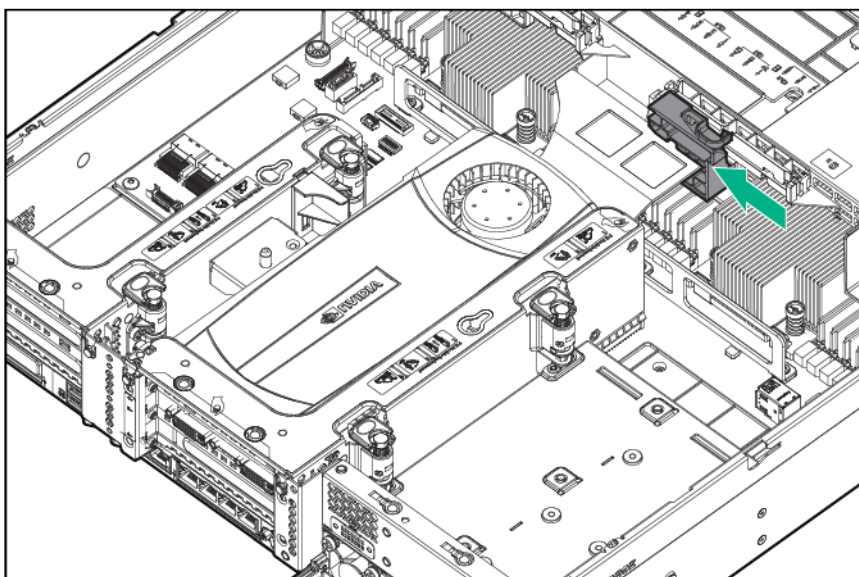

17. Install the access panel (on page 28).
18. Slide the server into the rack.
19. Connect each power cord to the server.
20. Connect each power cord to the power source.
21. Power up the server ("[Powering up the server](#)" on page 26).

## Eight-bay SFF front drive cage option for bay 1

To install the component:

1. Power down the server (on page 26).
2. Remove all power:
  - a. Disconnect each power cord from the power source.
  - b. Disconnect each power cord from the server.

3. Do one of the following:
  - Extend the server from the rack (on page 26).
  - Remove the server from the rack (on page 27).
4. Remove the access panel (on page 27).
5. Remove the fan cage (on page 29).
6. Remove the bay blank.

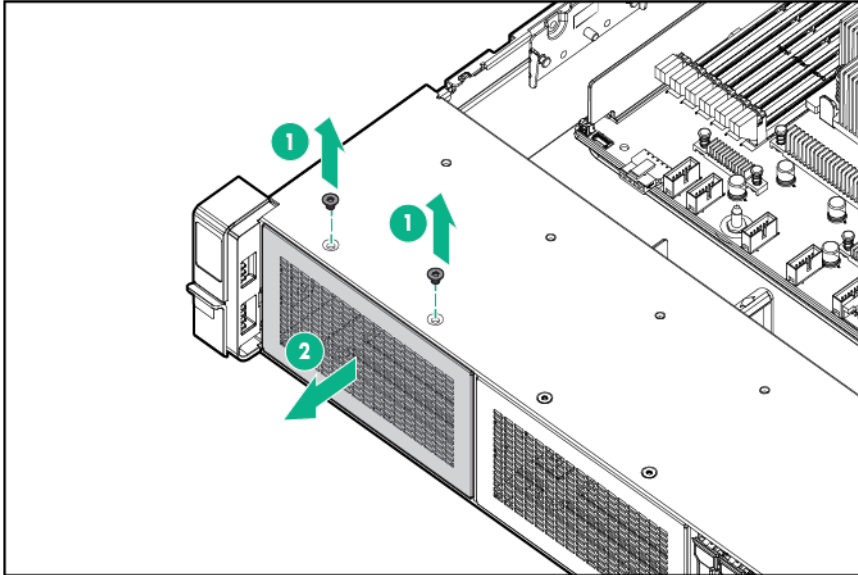

7. Install the 8SFF front drive cage option.

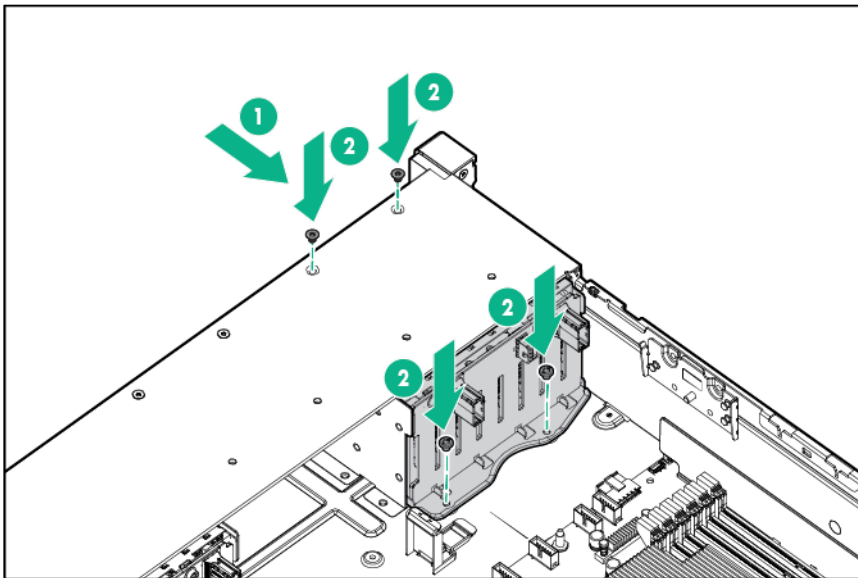

8. If installing drives, connect the power cable:

- o Single cable connection

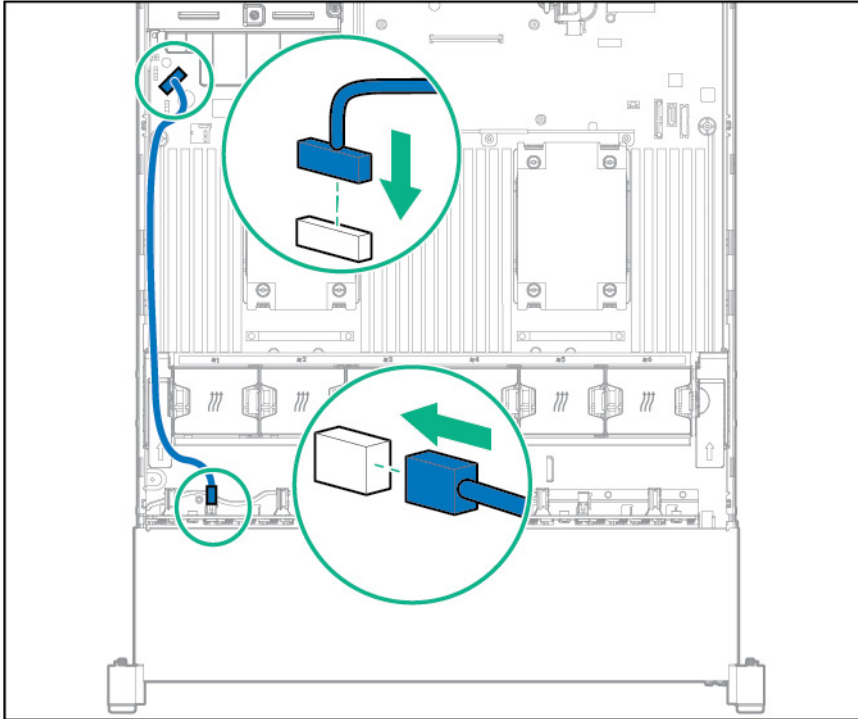

- o Y cable connection if the 2SFF option is installed in the rear bay

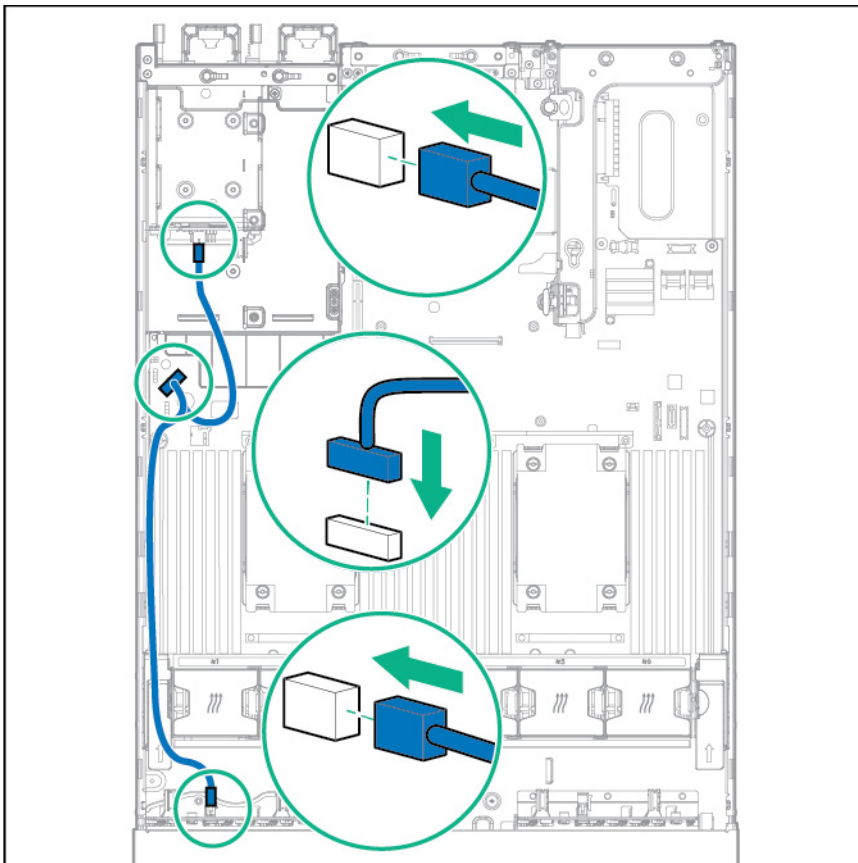

9. Connect the data cable in one of the following configurations:

- o Connected to a PCI expansion board

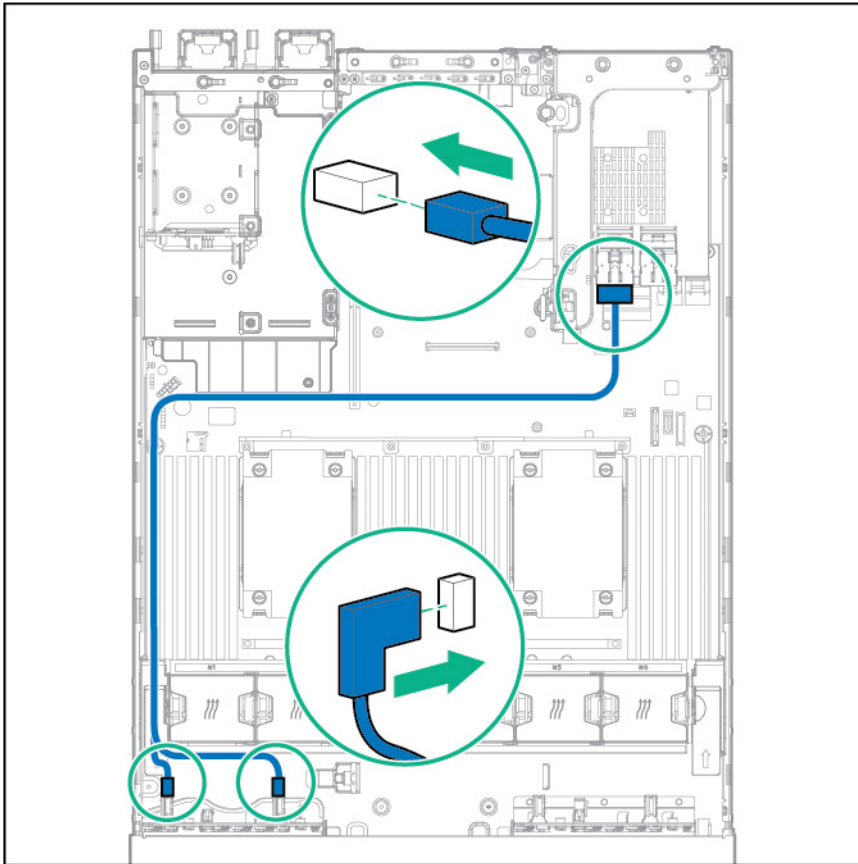

- Connected to an HPE 12G SAS Expander Card

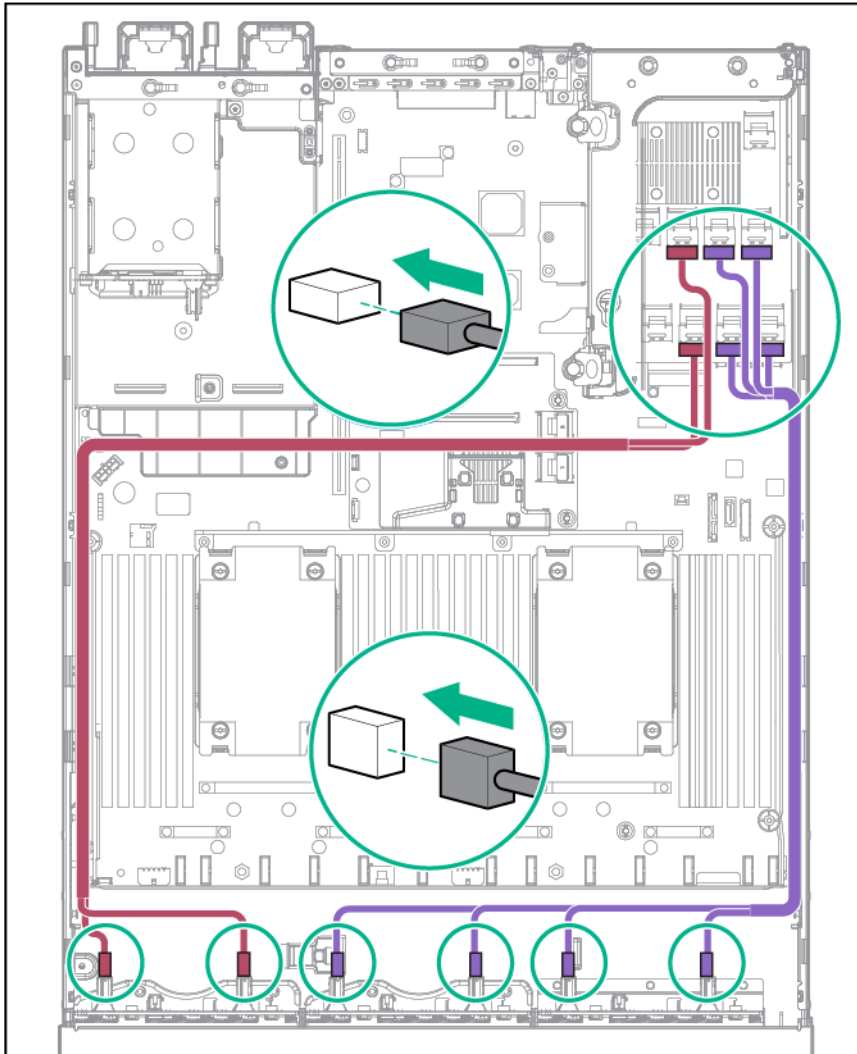

10. Install the fan cage.
11. Install the access panel (on page 28).
12. Slide the server into the rack.
13. Connect each power cord to the server.
14. Connect each power cord to the power source.
15. Power up the server ("[Powering up the server](#)" on page 26).

## Eight-bay SFF front drive cage option for bay 2

To install the component:

1. Power down the server (on page 26).
2. Remove all power:
  - a. Disconnect each power cord from the power source.
  - b. Disconnect each power cord from the server.
3. Do one of the following:
  - Extend the server from the rack (on page 26).

- o Remove the server from the rack (on page 27).
- 4. Remove the access panel (on page 27).
- 5. Remove the fan cage (on page 29).
- 6. Remove the bay blank.

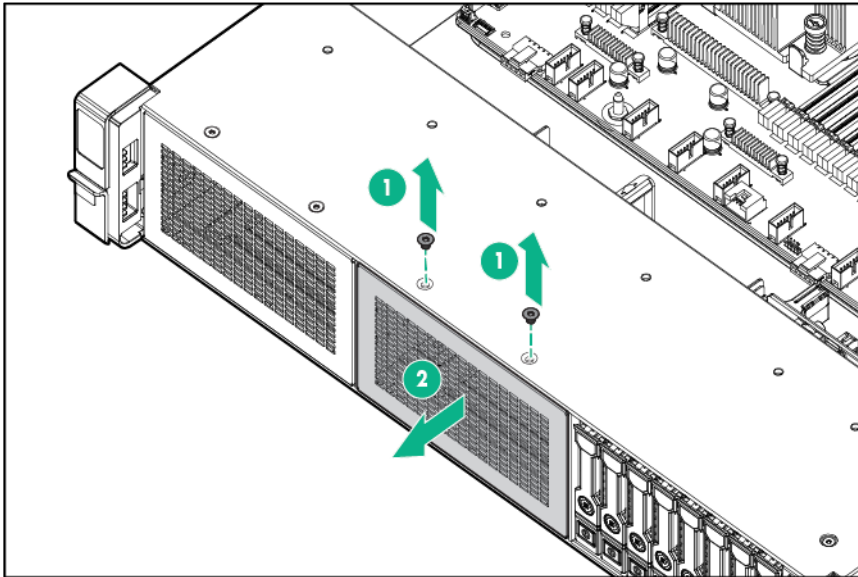

- 7. Install the 8SFF front drive cage option.

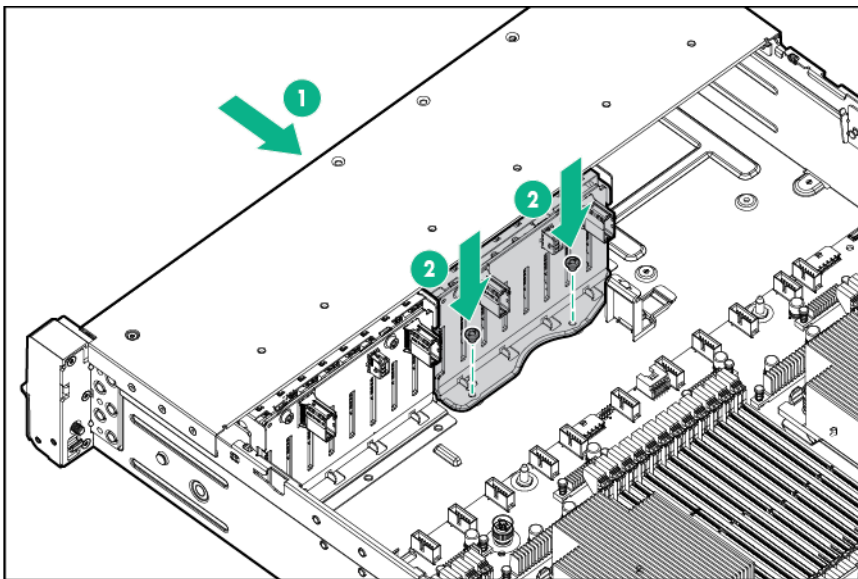

8. If installing drives, connect the power cable.

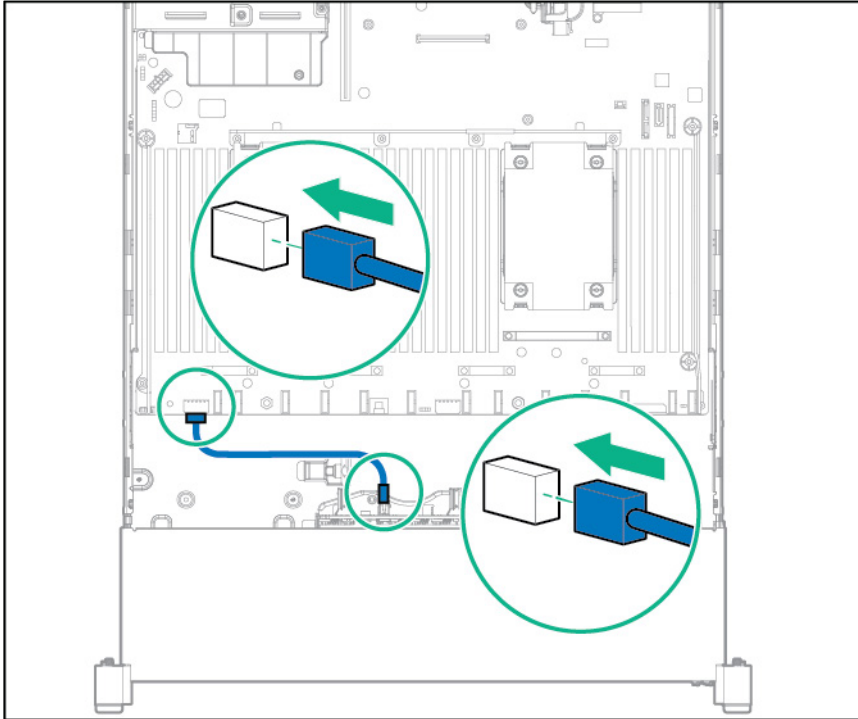

9. Connect the data cable in one of the following configurations:
- o Connected to a PCI expansion board

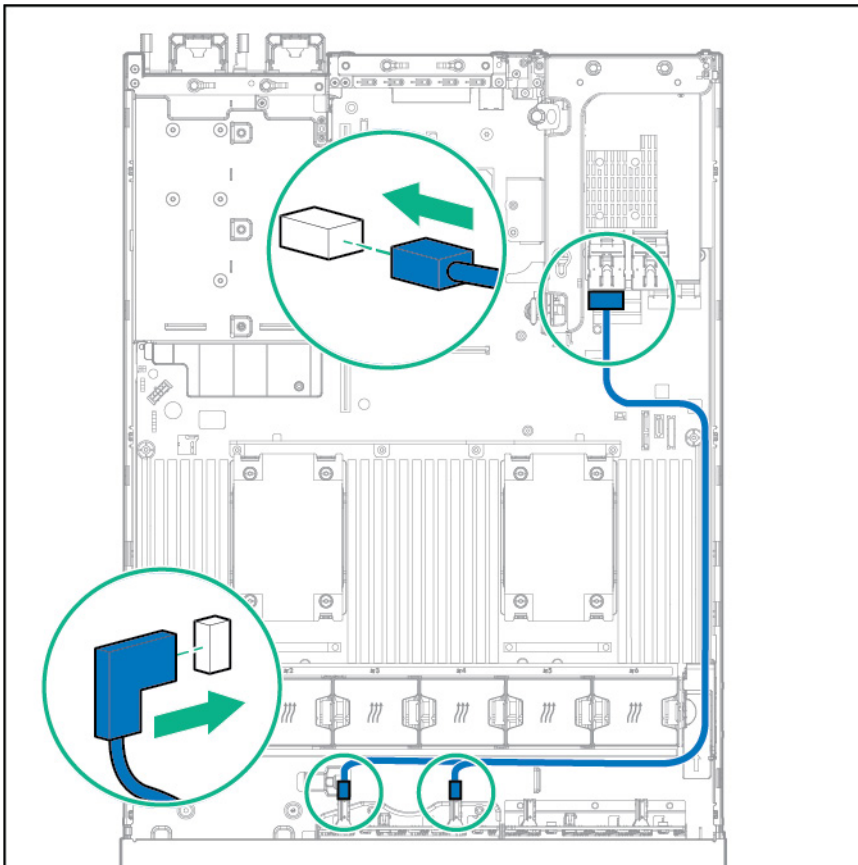



- o Connected to an HPE 12G SAS Expander Card

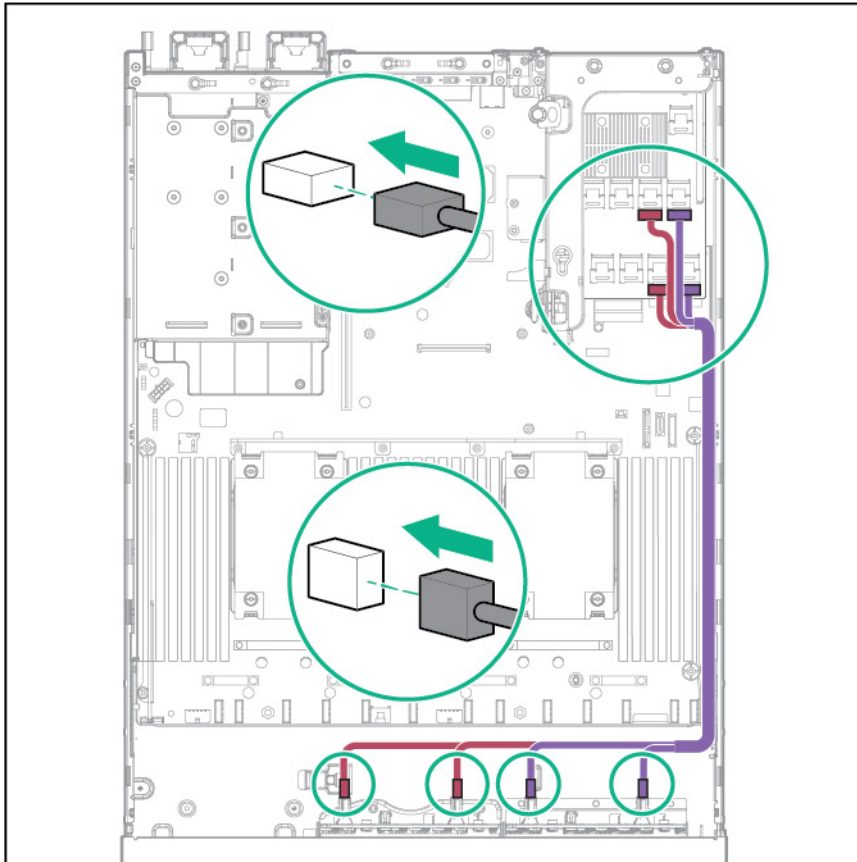

10. Install the fan cage.
11. Install the access panel (on page 28).
12. Slide the server into the rack.
13. Connect each power cord to the server.
14. Connect each power cord to the power source.
15. Power up the server ("[Powering up the server](#)" on page 26).

## Three-bay LFF rear drive cage option

Before installing this option the front bays must be fully populated with 12 LFF drives. High performance fans must be installed in all fan bays.

To install the component:

1. Power down the server (on page 26).
2. Remove all power:
  - a. Disconnect each power cord from the power source.
  - b. Disconnect each power cord from the server.
3. Do one of the following:
  - o Extend the server from the rack (on page 26).
  - o Remove the server from the rack (on page 27).
4. Remove the access panel (on page 27).

5. If installed, remove the secondary riser board. The secondary riser board is not supported with a three-bay LFF rear configuration.

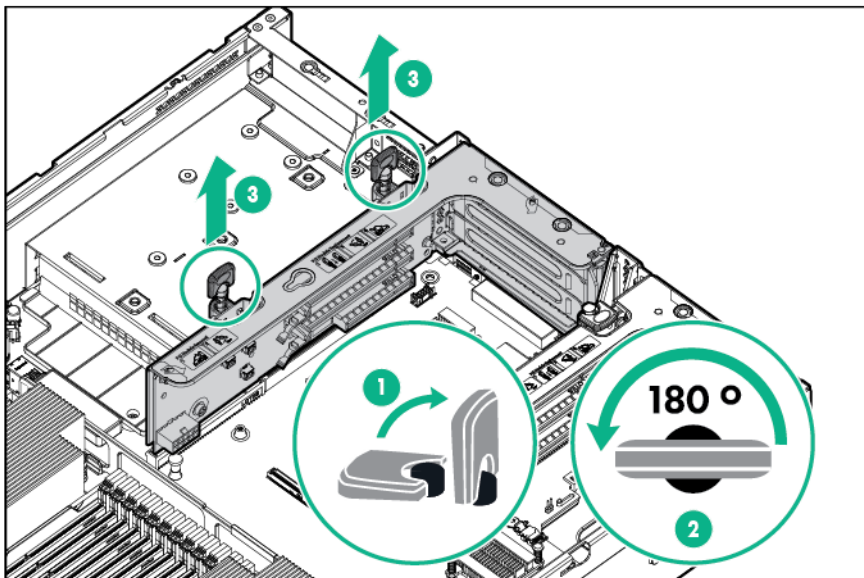

6. Remove the rear wall blank.

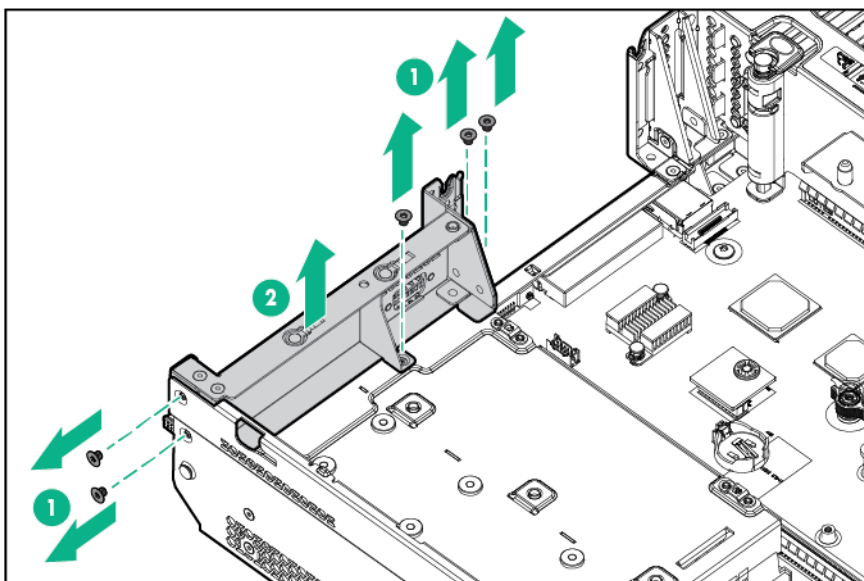

7. Install the three-bay LFF rear drive cage option.

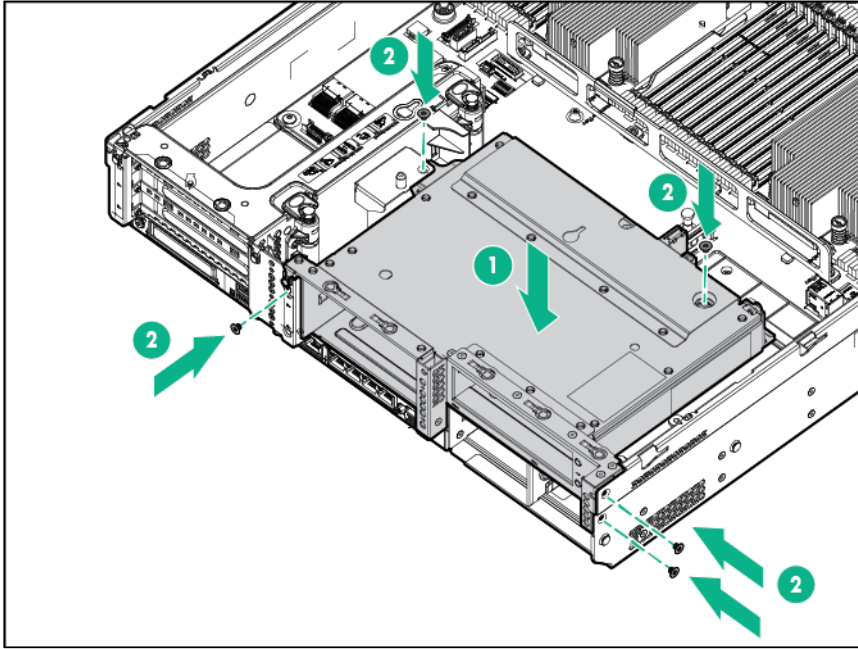

8. Install blanks or drives.
9. If installing drives, connect the power cable.

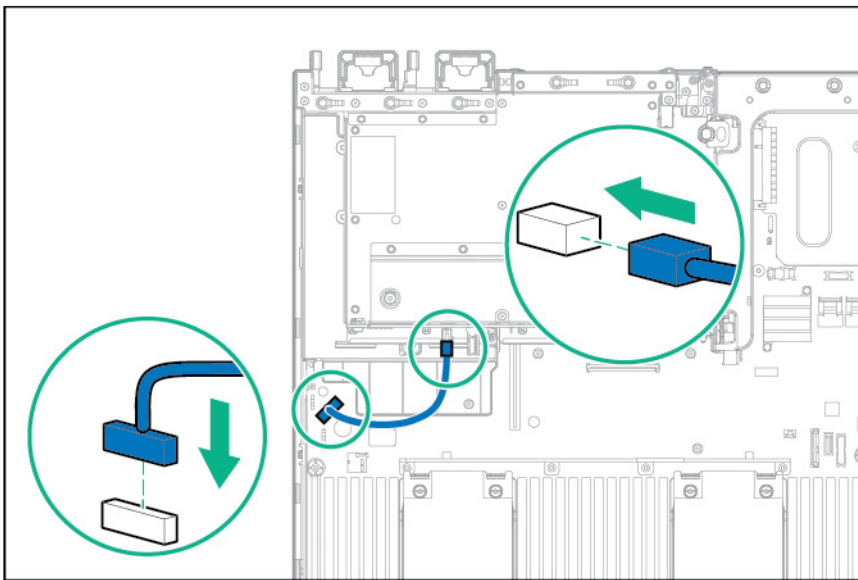

10. Connect the data cable in one of the following configurations:

- Connected to onboard SATA connectors

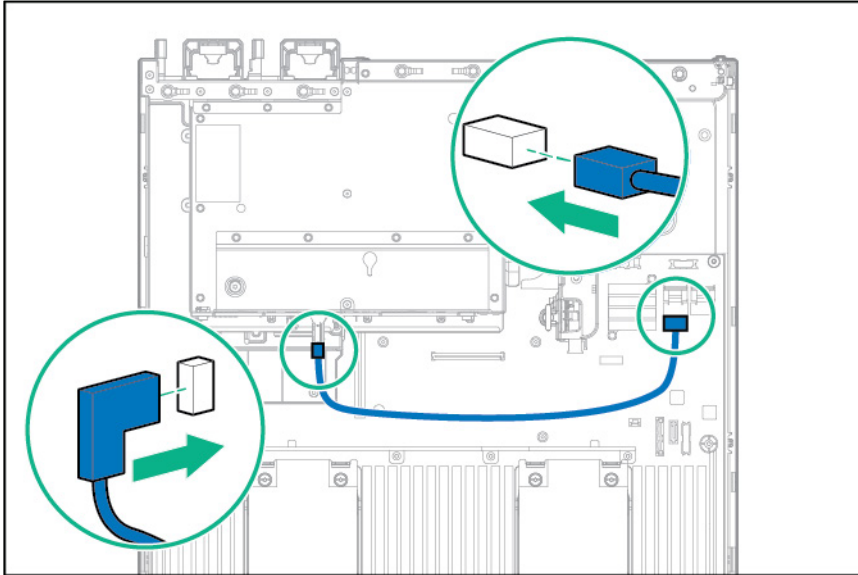

- Connected to a PCI expansion board

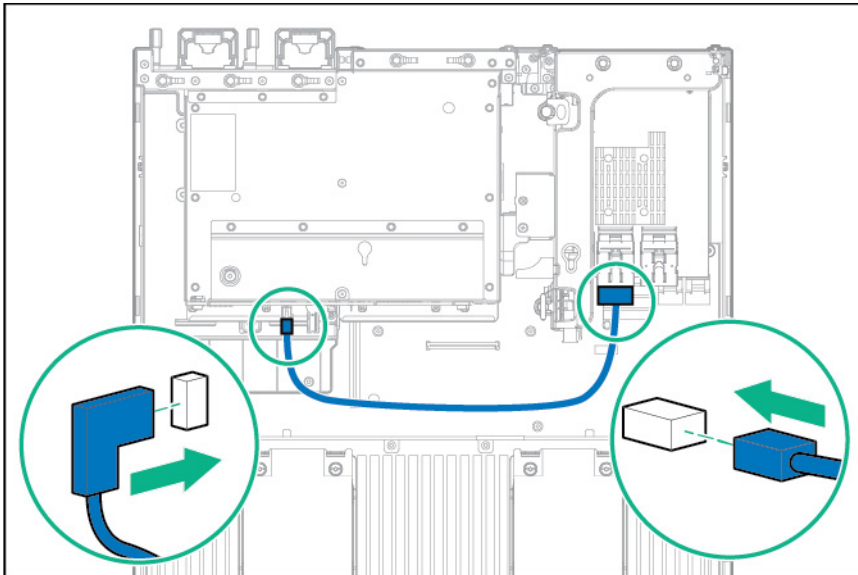

- o Connected to a PCI expansion board and the 12 LFF backplane

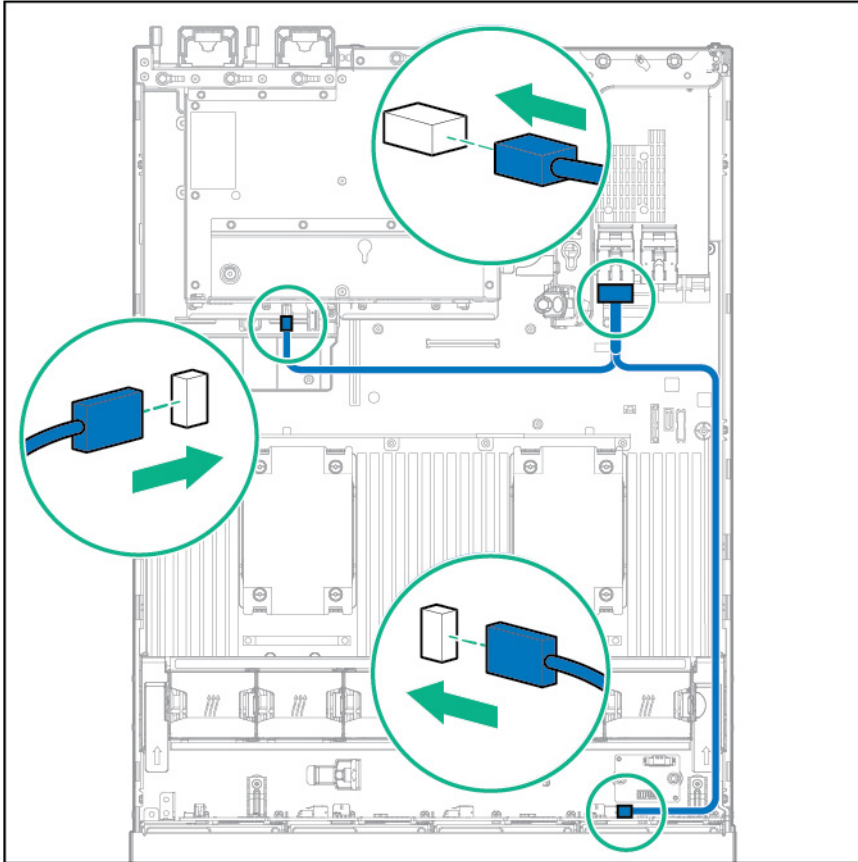

- o Connected to an HPE 12G SAS Expander Card

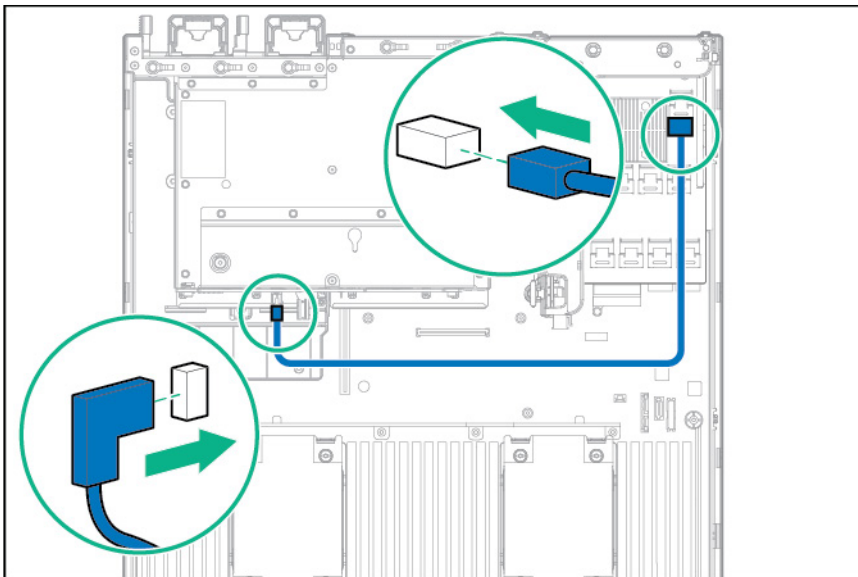

11. Install the access panel (on page 28).
12. Slide the server into the rack.
13. Connect each power cord to the server.
14. Connect each power cord to the power source.
15. Power up the server ("[Powering up the server](#)" on page 26).

# Two-bay SFF front drive cage option

The front bay installation requires a universal media bay to be installed.

To install the component:

1. Power down the server (on page 26).
2. Remove all power:
  - a. Disconnect each power cord from the power source.
  - b. Disconnect each power cord from the server.
3. Do one of the following:
  - o Extend the server from the rack (on page 26).
  - o Remove the server from the rack (on page 27).
4. Remove the access panel (on page 27).
5. Remove the front bay blank.

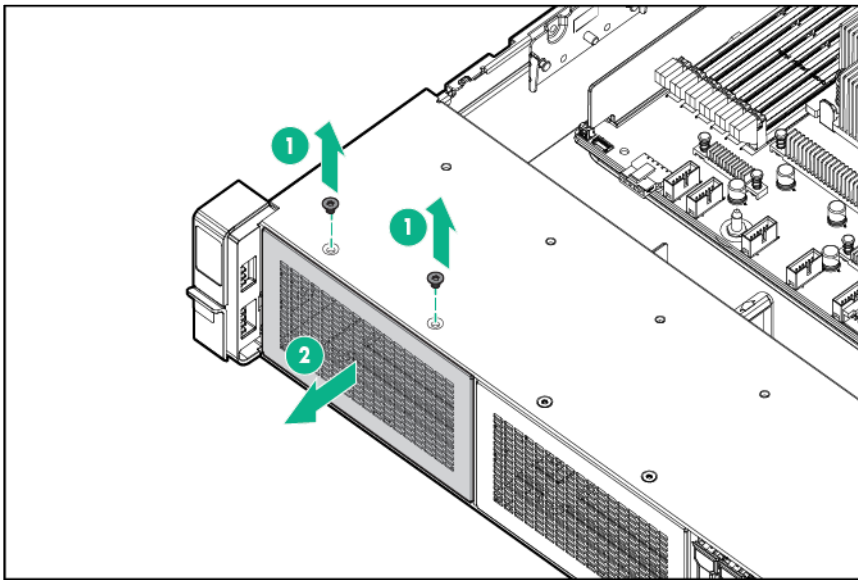

6. Remove the optical disk drive tray from the universal media bay.

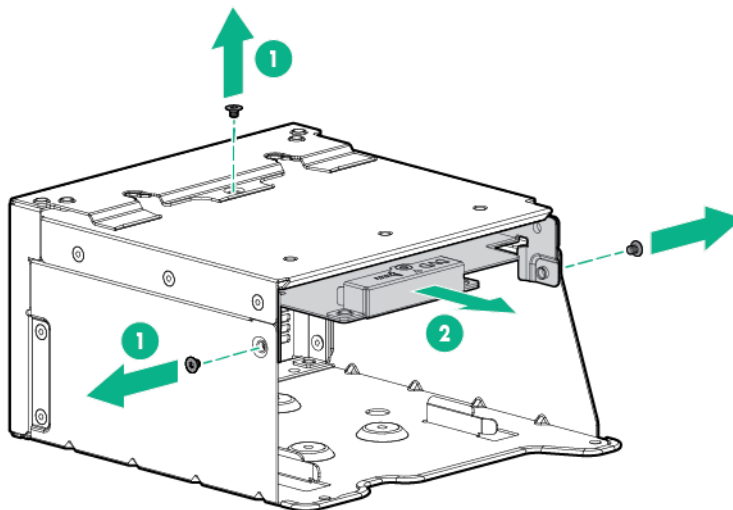

7. Remove the SFF drive blank from the universal media bay.

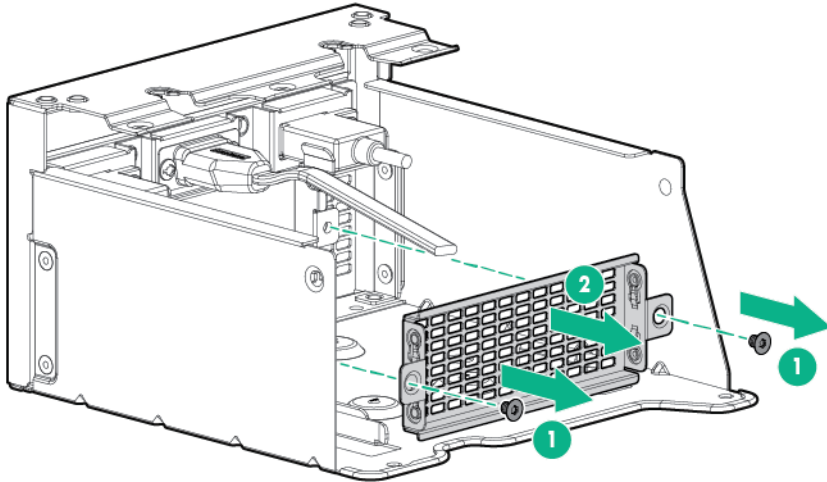

8. Install the drive cage into the universal media bay.

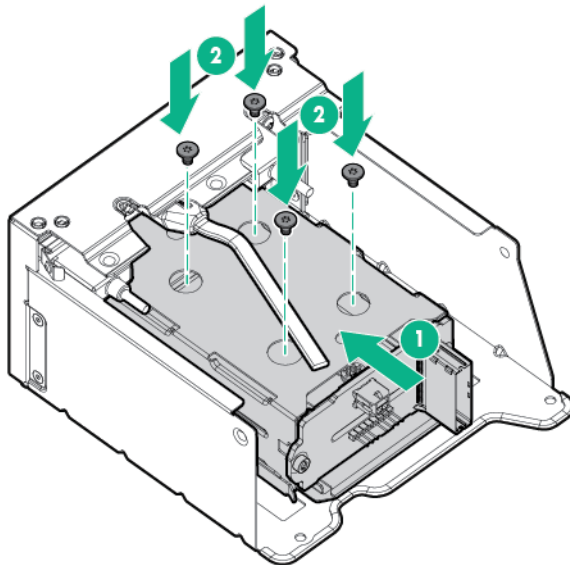

9. Install the universal media bay.

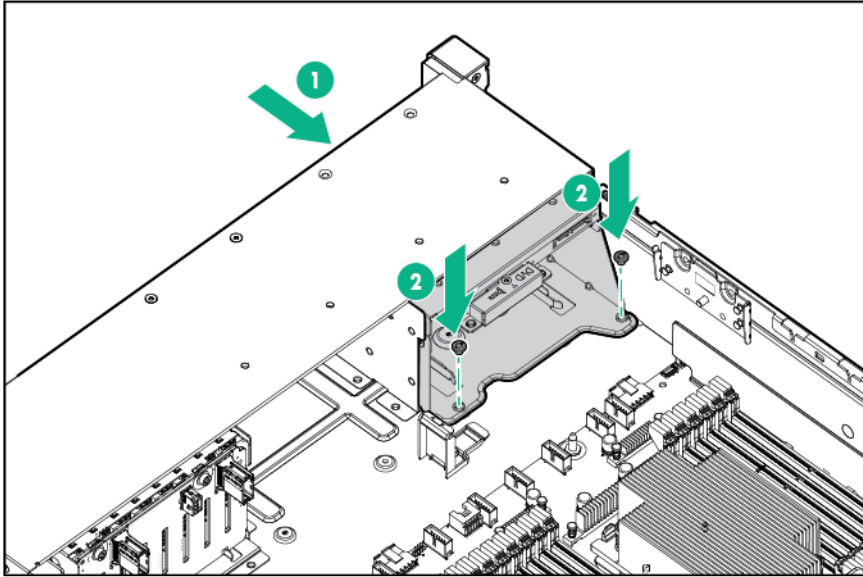

10. Connect the power cable.

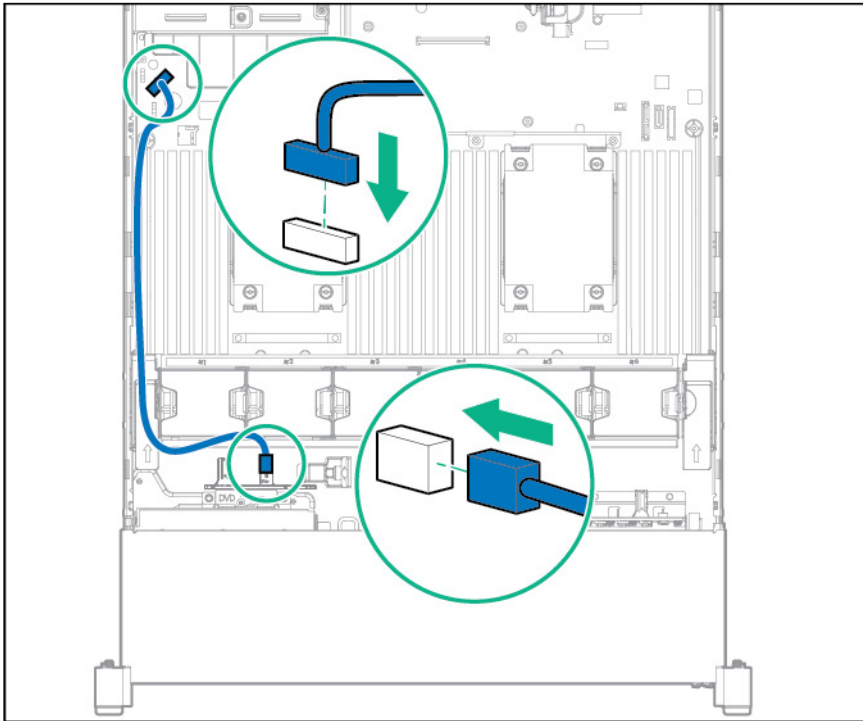

11. Connect the data cable in one of the following two configurations:



- o Connected to a PCI expansion board

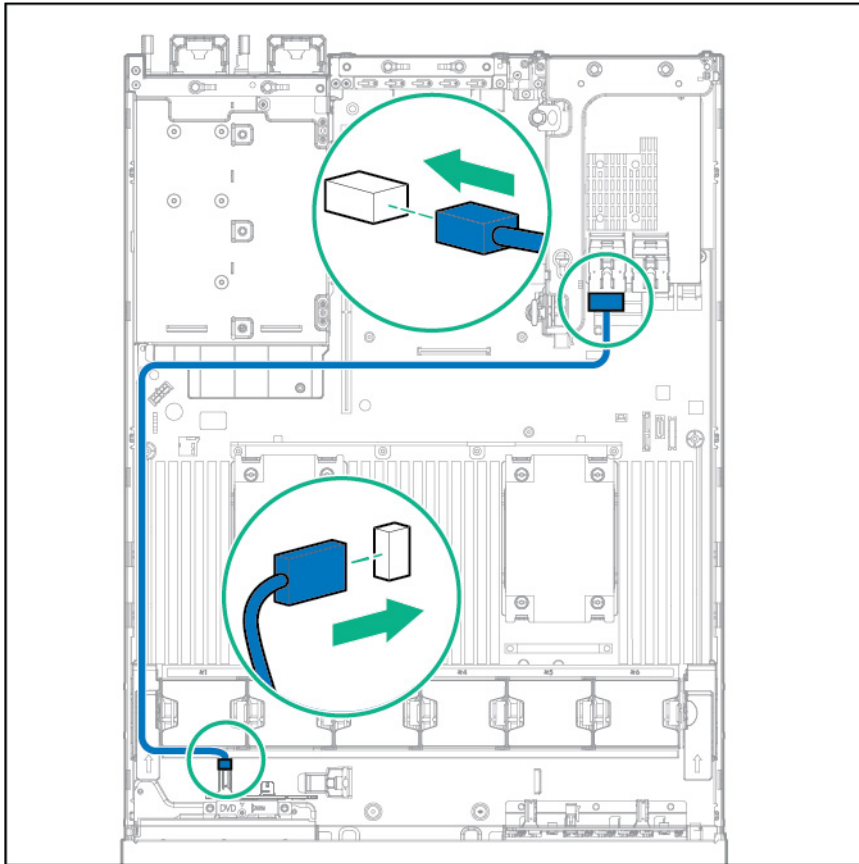

- Connected to the onboard x4 SATA connector

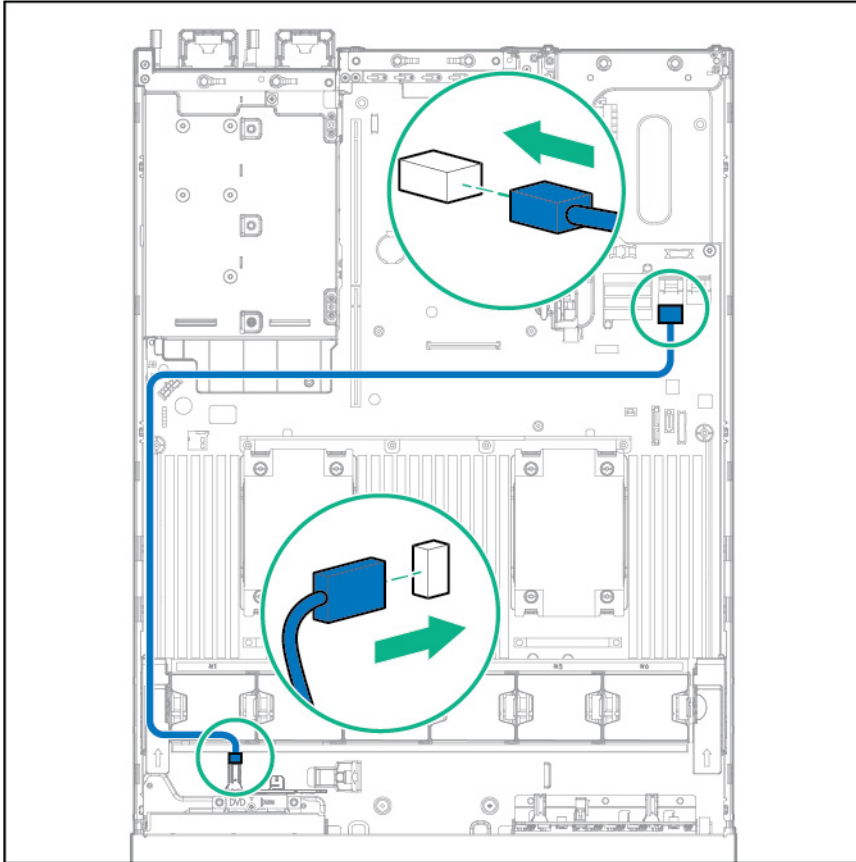

12. Install the access panel (on page 28).
13. Slide the server into the rack.
14. Connect each power cord to the server.
15. Connect each power cord to the power source.
16. Power up the server ("Powering up the server" on page 26).

## Two-bay SFF rear drive cage option

For rear drive cage installation, the front bays must be fully populated using the 12 LFF or 24 SFF drives. High performance fans must be installed in all fan bays.

To install the component:

1. Power down the server (on page 26).
2. Remove all power:
  - a. Disconnect each power cord from the power source.
  - b. Disconnect each power cord from the server.
3. Do one of the following:
  - Extend the server from the rack (on page 26).
  - Remove the server from the rack (on page 27).
4. Remove the access panel (on page 27).
5. Remove the secondary riser cage or PCI blank:

- o Secondary riser cage

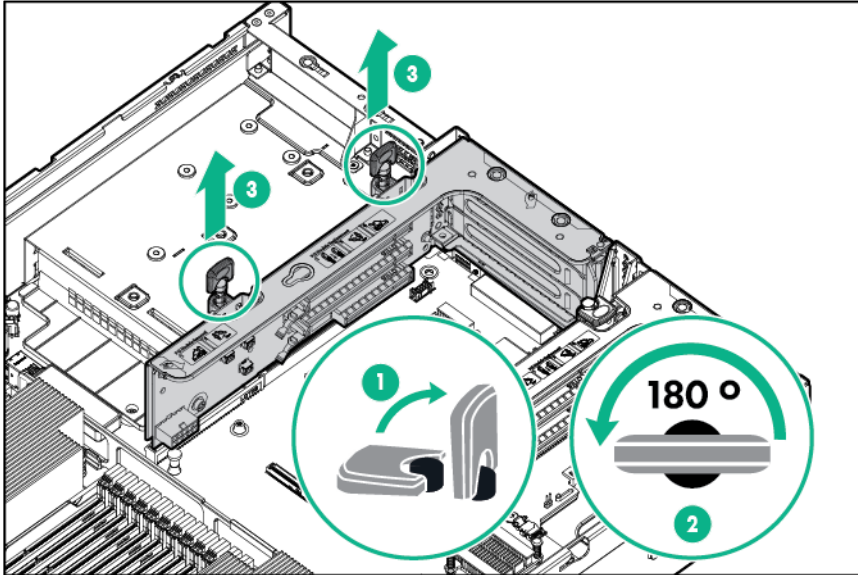

- o PCI blank

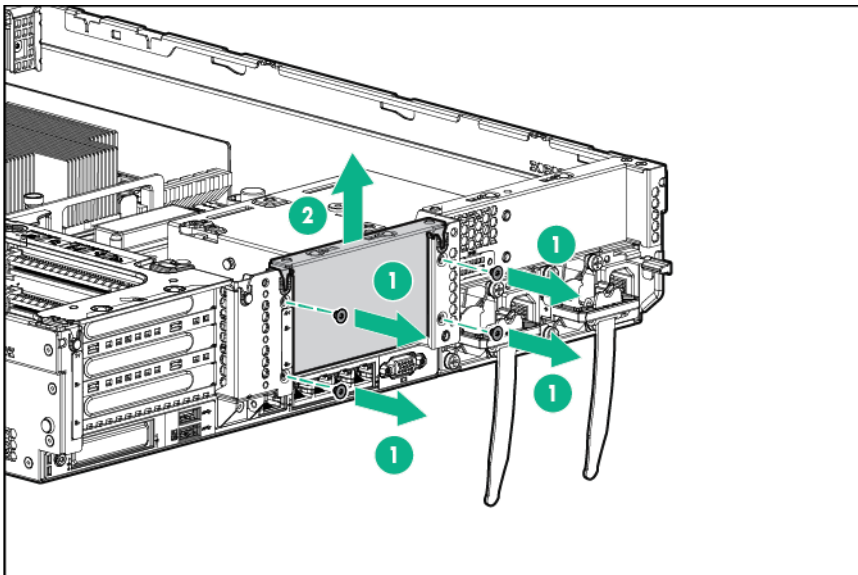

6. Remove the rear wall blank.

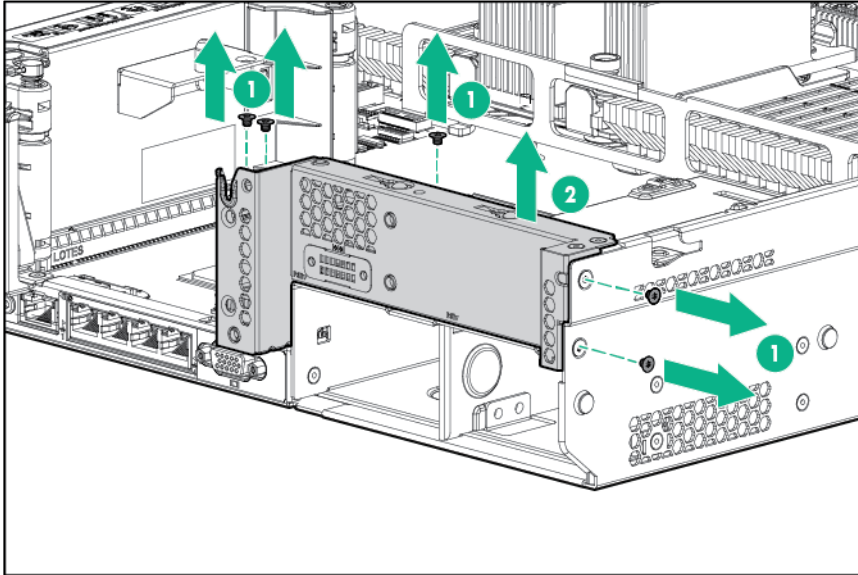

7. Install the drive cage compatible rear wall.

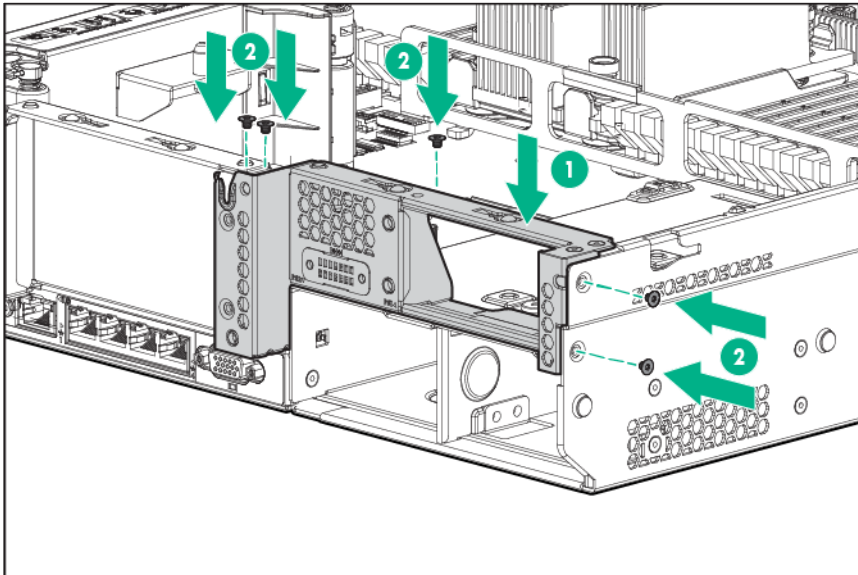

8. Install the rear two-bay SFF drive cage option.

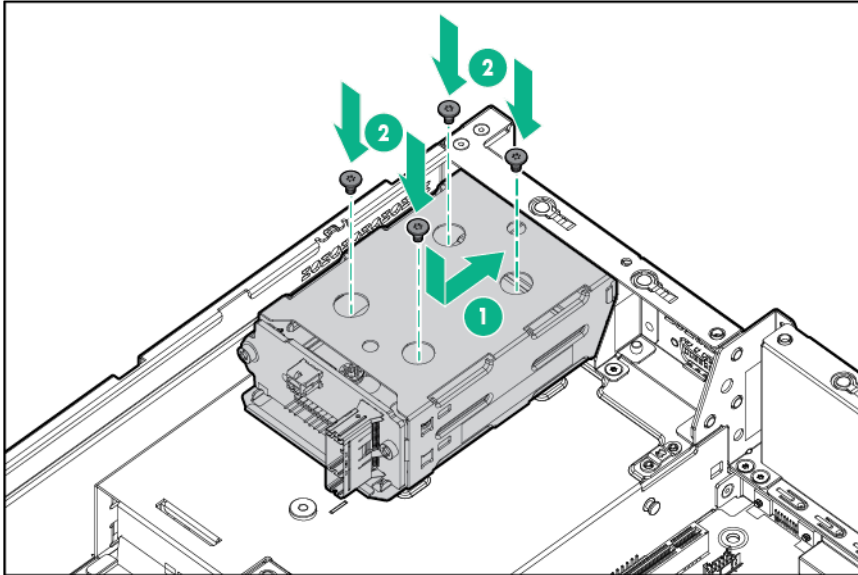

9. Install blanks or drives.
10. Install the secondary riser cage or PCI blank.
11. If installing drives, connect the power cable:
  - o Single cable connection with 12 LFF configuration in the front

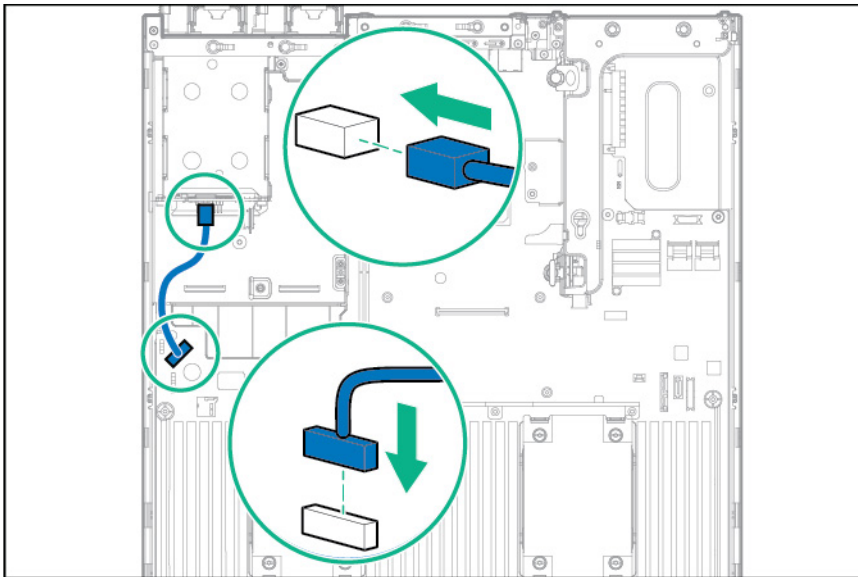

- o Y cable connection with 24 SFF drive configuration in the front

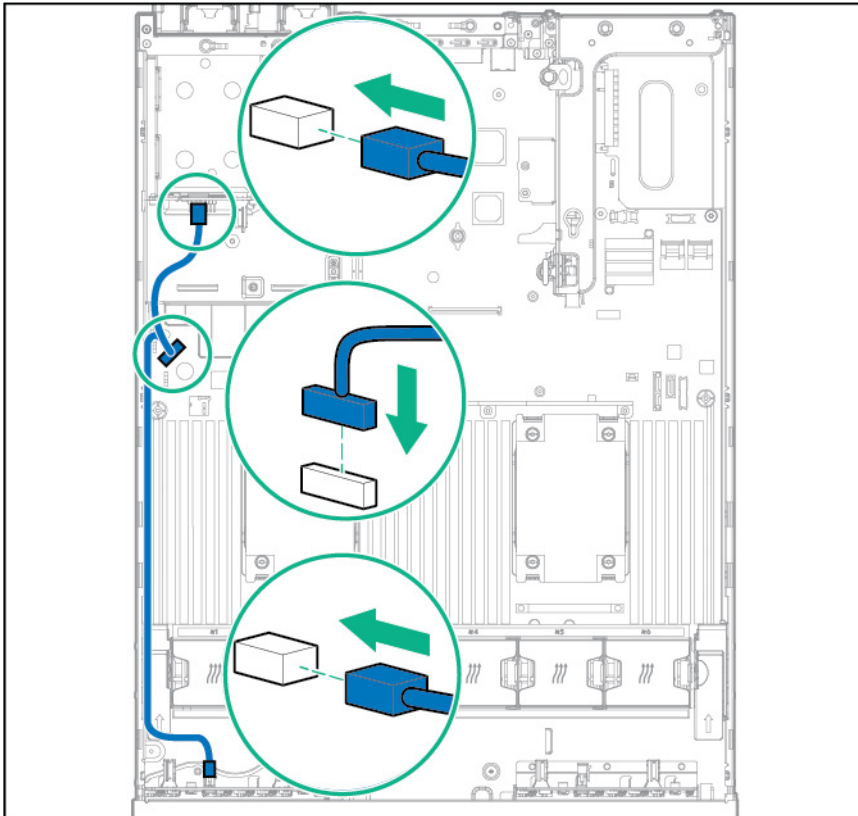

12. Connect the data cable in one of the following configurations:

- o Connected to the onboard x4 SATA connector

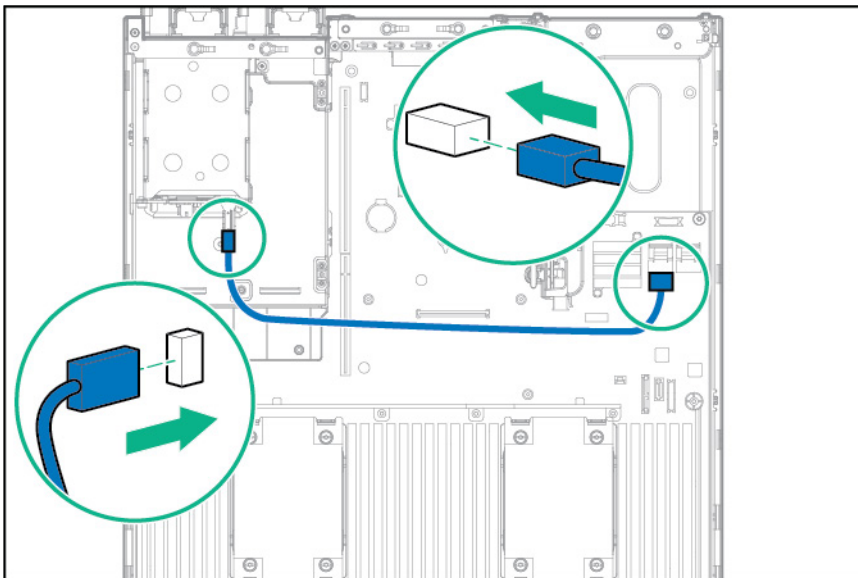

- Connected to the x2 SATA port and optical disk drive connector

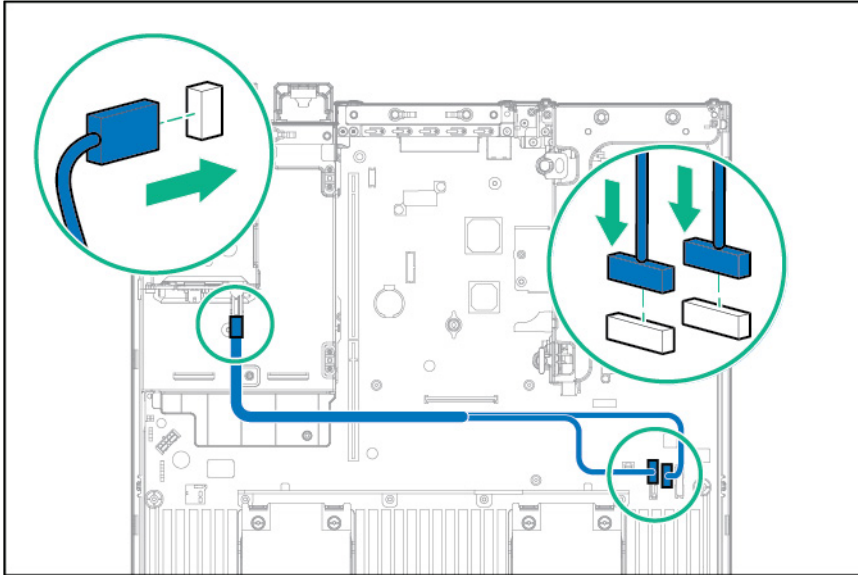

- Connected to a PCI expansion board

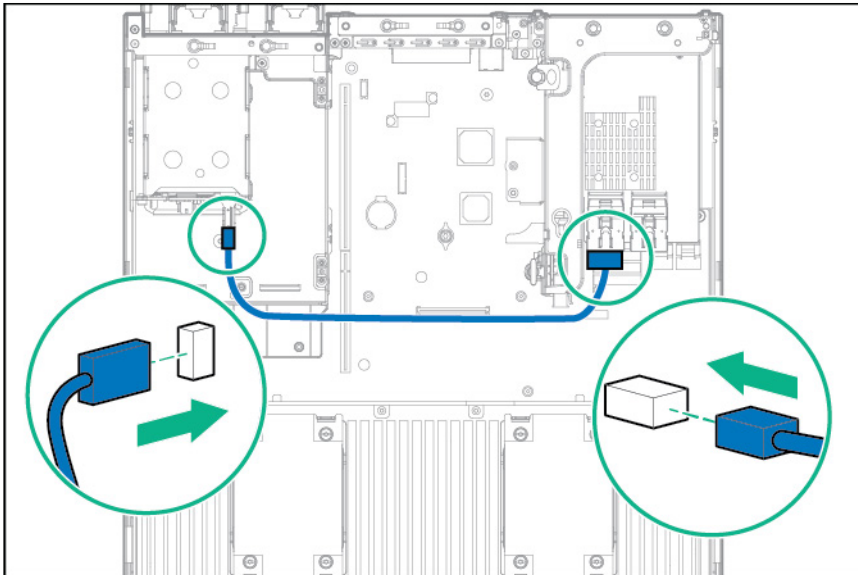

- Connected to a PCI expansion board and the 12 LFF backplane

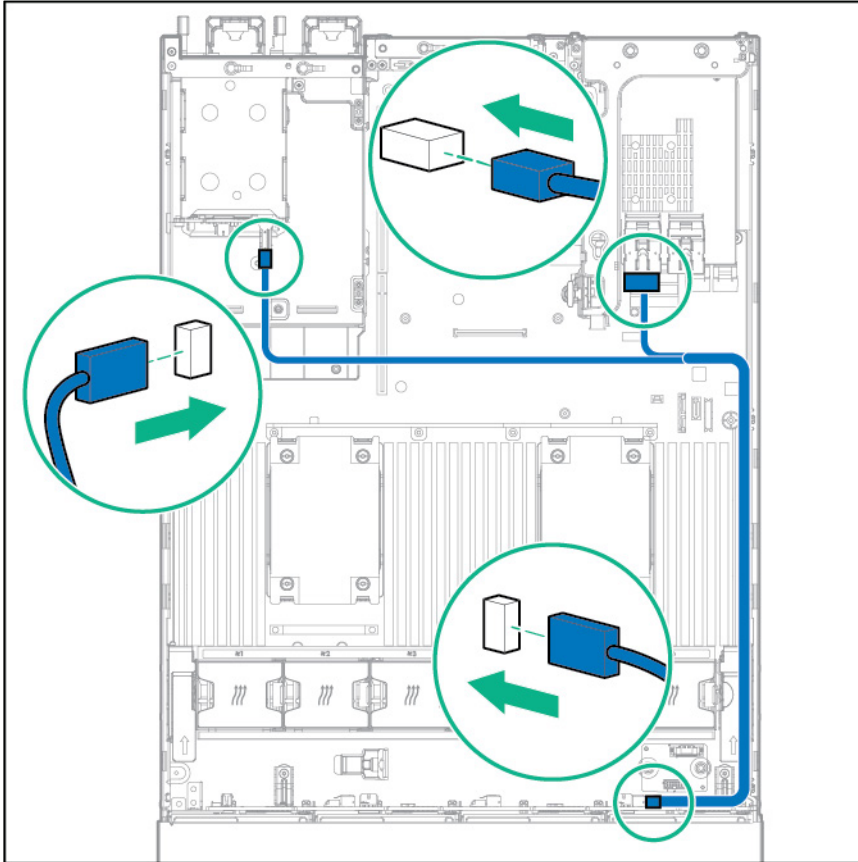

- Connected to an HPE 12G SAS Expander Card

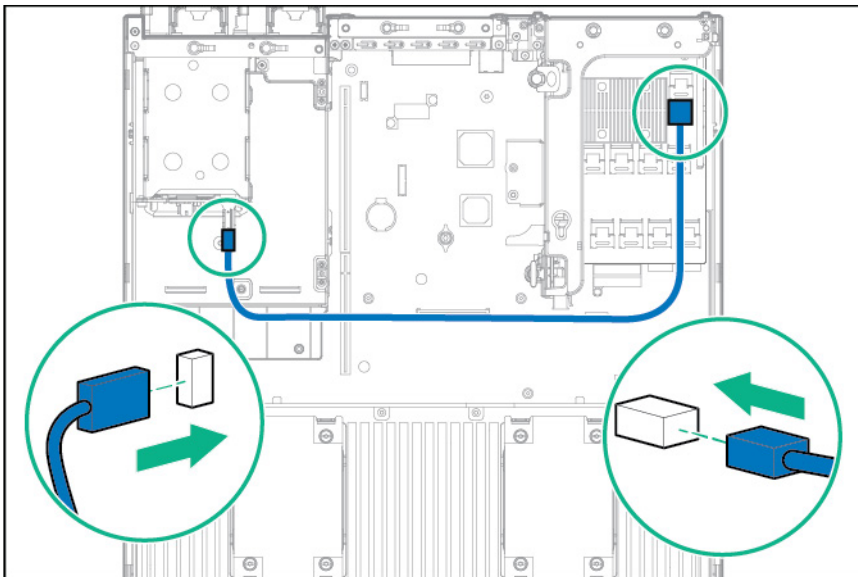

13. Install the access panel (on page 28).
14. Slide the server into the rack.
15. Connect each power cord to the server.
16. Connect each power cord to the power source.
17. Power up the server ("[Powering up the server](#)" on page 26).



# Systems Insight Display power switch module option

This option is not supported in servers configured with 4LFF or 12LFF drives.

To install the component:

1. Power down the server (on page 26).
2. Remove all power:
  - a. Disconnect each power cord from the power source.
  - b. Disconnect each power cord from the server.
3. Do one of the following:
  - o Extend the server from the rack (on page 26).
  - o Remove the server from the rack (on page 27).
4. Remove the access panel (on page 27).
5. Remove the air baffle (on page 32).
6. Remove the fan cage (on page 29).

---

**CAUTION:** When routing cables, always be sure that the cables are not in a position where they can be pinched or crimped.

---

7. Remove the cabled power switch module. Retain the T-10 screw for later use.

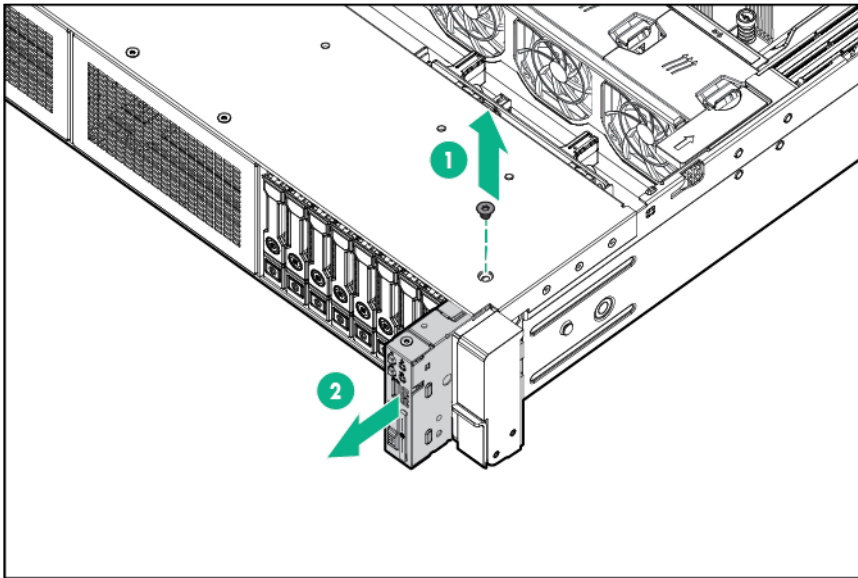

8. Route the cable through the opening in the front of the server, and then install the SID power switch module. Secure the module using the existing screw.

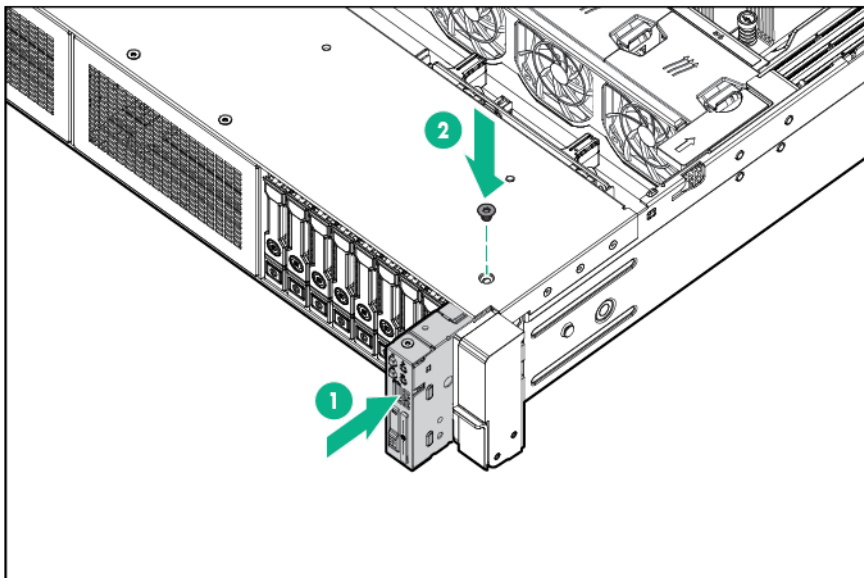

9. Connect the SID module cable to the system board power switch module connector.

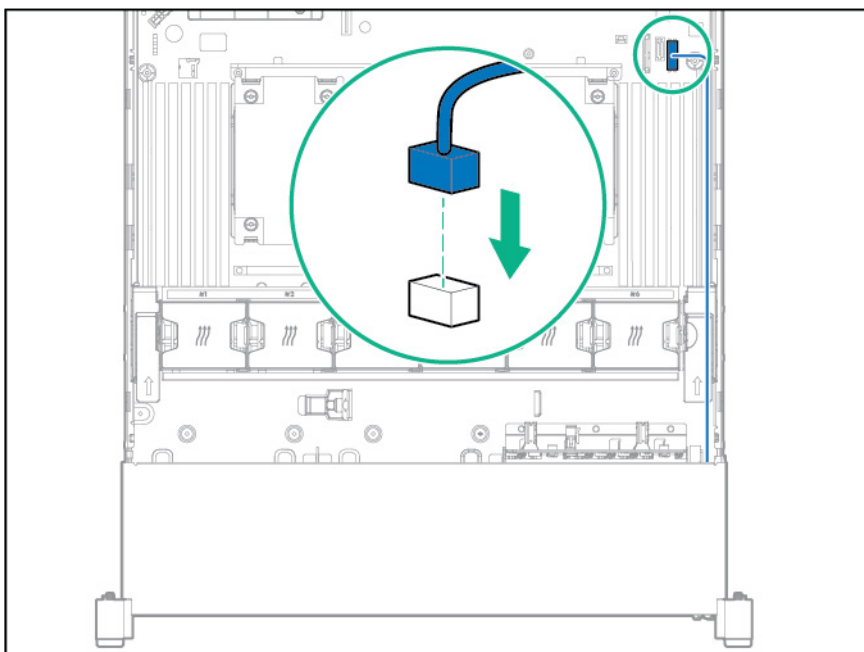

10. Install the fan cage.
11. Install the air baffle (on page 33).
12. Install the access panel (on page 28).
13. Slide the server into the rack.
14. Connect each power cord to the server.
15. Connect each power cord to the power source.
16. Power up the server ("Powering up the server" on page 26).

# Location Discovery Services ear option

To install the component:

1. Power down the server (on page 26).
2. Remove all power:
  - a. Disconnect each power cord from the power source.
  - b. Disconnect each power cord from the server.
3. Do one of the following:
  - o Extend the server from the rack (on page 26).
  - o Remove the server from the rack (on page 27).
4. Remove the access panel (on page 27).
5. Remove the fan cage (on page 29).
6. Remove the cable protection panel from the left side of the server.

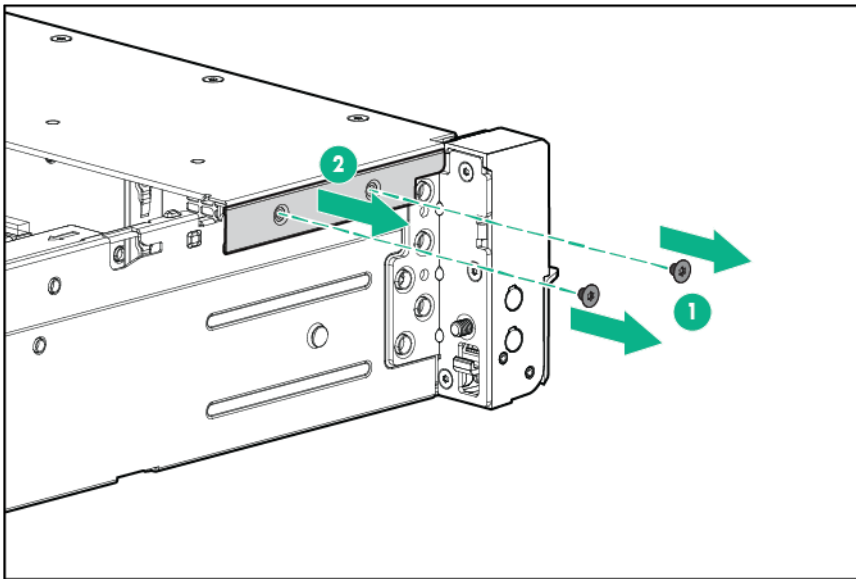

7. Remove the standard ear.

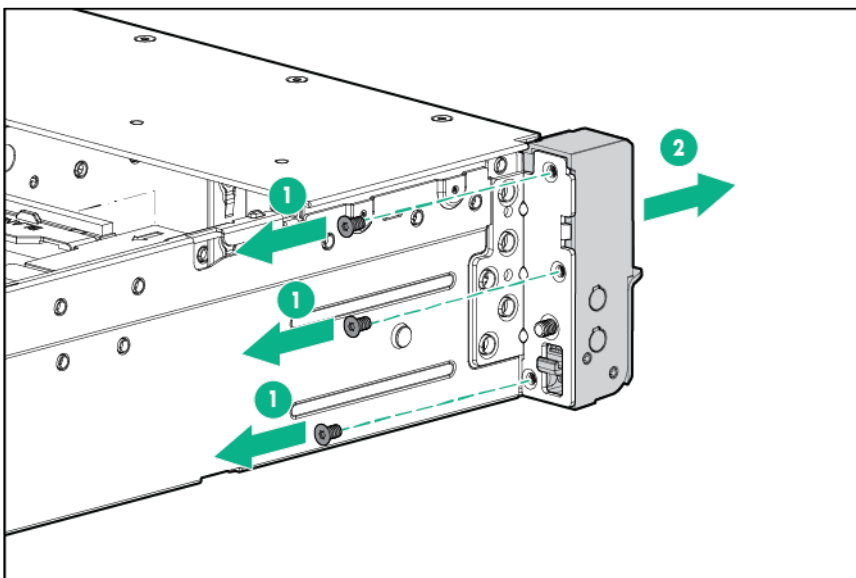

8. Install the Location Discovery Services ear option and route the discovery service cable through side channel.

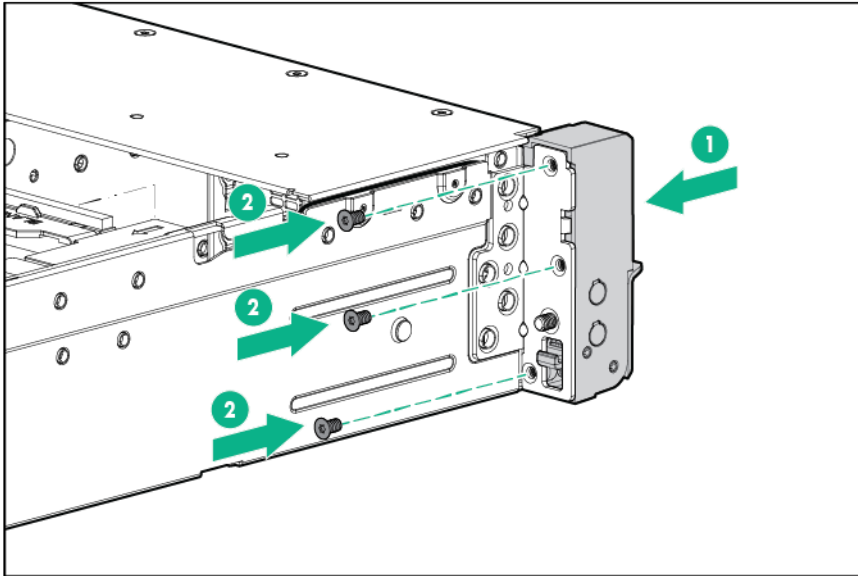

9. Install the cable protection panel.

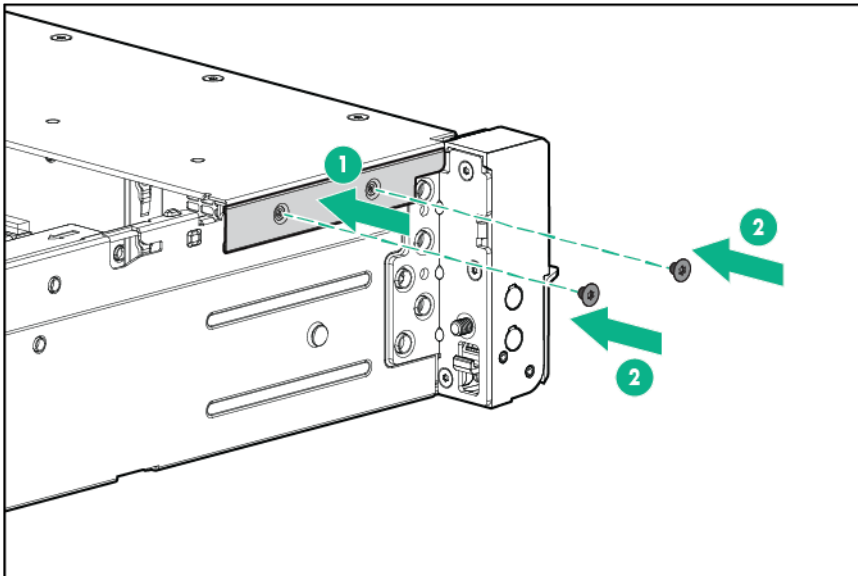

10. Connect the discovery service cable.

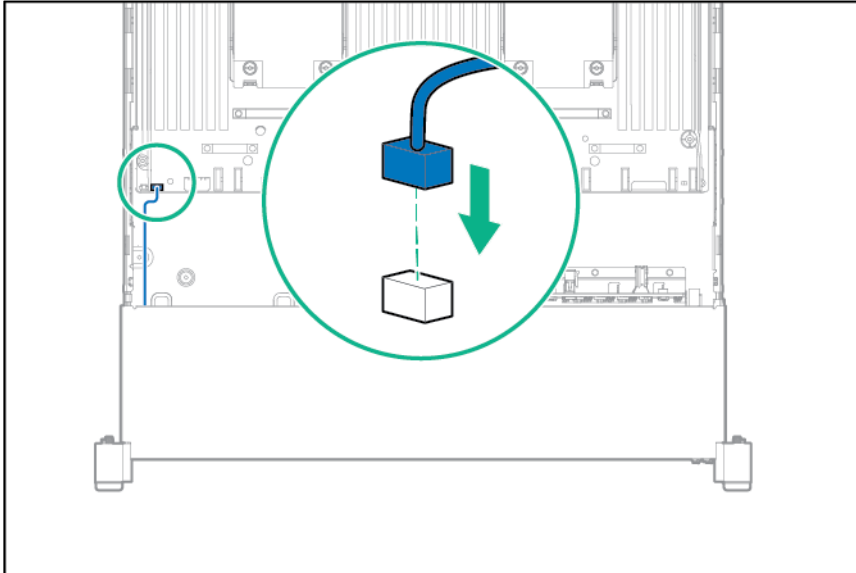

11. Install the fan cage.
12. Install the access panel (on page 28).
13. Slide the server into the rack.
14. Connect each power cord to the server.
15. Connect each power cord to the power source.
16. Power up the server ("[Powering up the server](#)" on page 26).

## Smart Storage Battery

To install the component:

1. Power down the server (on page 26).
2. Remove all power:
  - a. Disconnect each power cord from the power source.
  - b. Disconnect each power cord from the server.
3. Do one of the following:
  - o Extend the server from the rack (on page 26).
  - o Remove the server from the rack (on page 27).
4. Remove the access panel (on page 27).
5. Remove the air baffle (on page 32).
6. Remove the fan cage (on page 29).

7. Install the Smart Storage battery.

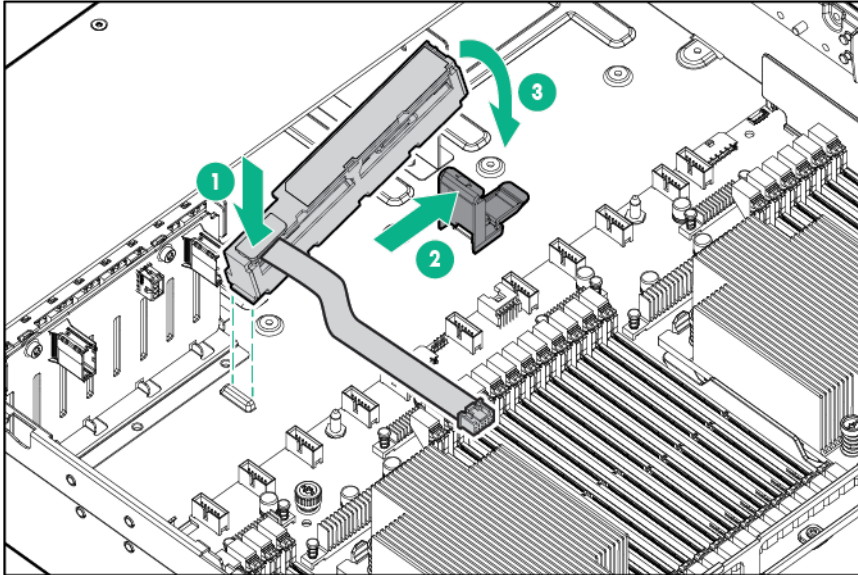

8. Route the cable.

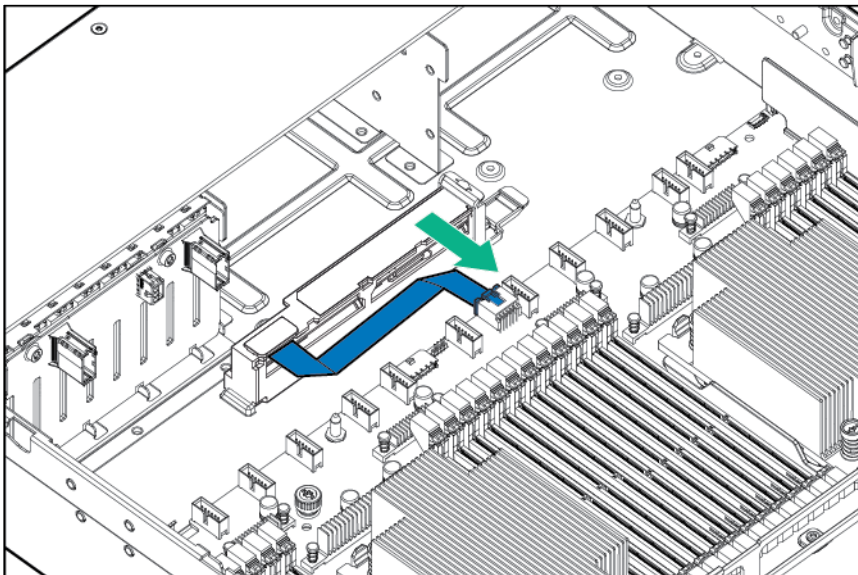

9. Install the fan cage.
10. Install the air baffle (on page 33).
11. Install the access panel (on page 28).
12. Slide the server into the rack.
13. Connect each power cord to the server.
14. Connect each power cord to the power source.
15. Power up the server ("Powering up the server" on page 26).

## FlexibleLOM option

To install the component:

1. Power down the server (on page 26).
2. Remove all power:

- a. Disconnect each power cord from the power source.
- b. Disconnect each power cord from the server.
3. Do one of the following:
  - o Extend the server from the rack (on page 26).
  - o Remove the server from the rack (on page 27).
4. Remove the access panel (on page 27).
5. Remove the FlexibleLOM PCIe blank.

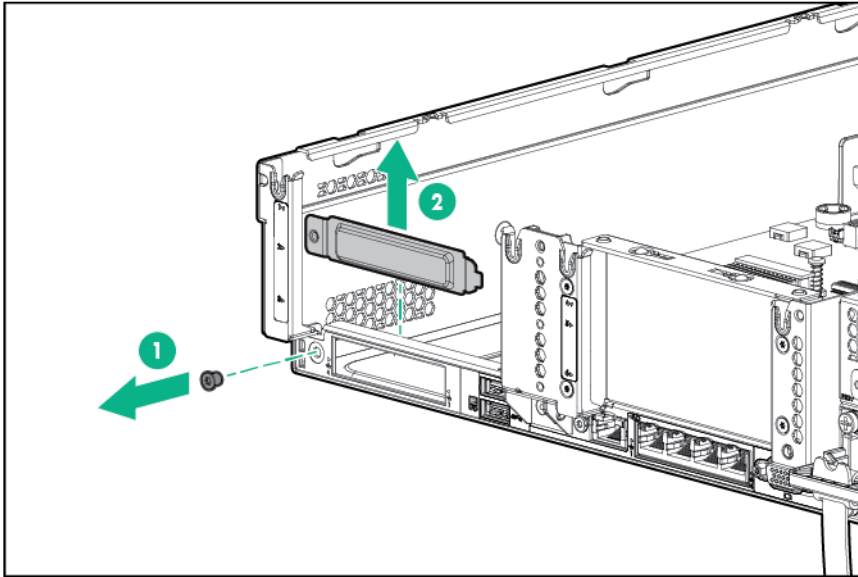

6. Install the component:
  - a. Firmly seat the FlexibleLOM in the slot.
  - b. Tighten the thumbscrew.

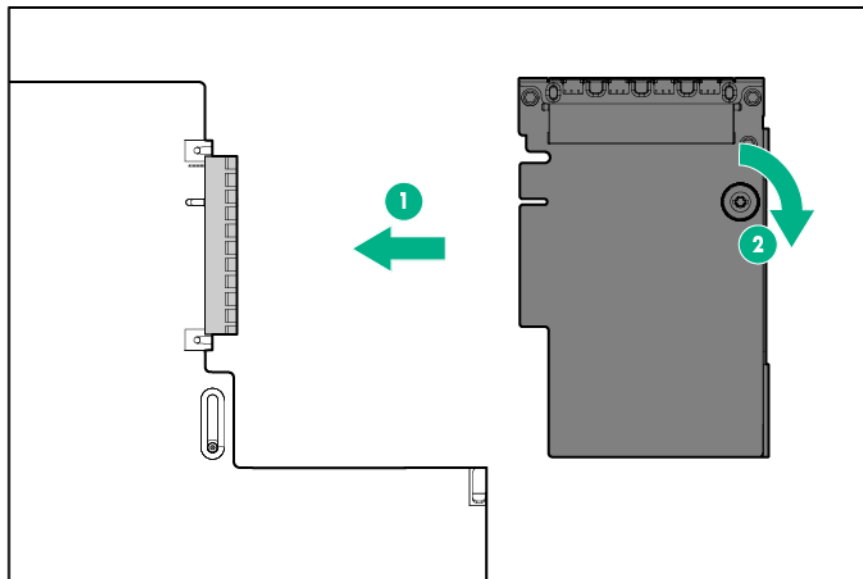

7. Install the access panel (on page 28).
8. Slide the server into the rack.
9. Connect the LAN segment cables.
10. Connect each power cord to the server.
11. Connect each power cord to the power source.
12. Power up the server ("[Powering up the server](#)" on page 26).

## Expansion board options

The server supports PCI Express expansion boards. The server ships with PCIe riser boards and expansion slots. PCIe expansion boards are supported with optional riser boards.

### Removing an expansion slot blank

- ⚠ WARNING:** To reduce the risk of personal injury, electric shock, or damage to the equipment, remove the power cord to remove power from the server. The front panel Power On/Standby button does not completely shut off system power. Portions of the power supply and some internal circuitry remain active until AC power is removed.
- 
- ⚠ CAUTION:** For proper cooling, do not operate the server without the access panel, baffles, expansion slot covers, or blanks installed. If the server supports hot-plug components, minimize the amount of time the access panel is open.
- 

To remove the component:

1. Power down the server (on page 26).
2. Remove all power:
  - a. Disconnect each power cord from the power source.
  - b. Disconnect each power cord from the server.
3. Do one of the following:
  - o Extend the server from the rack (on page 26).
  - o Remove the server from the rack (on page 27).
4. Remove the access panel (on page 27).
5. Remove the PCIe riser cage:
  - o Primary PCIe riser cage ("[Remove the PCI riser cage](#)" on page 30)
  - o Secondary PCIe riser cage ("[3-slot PCI riser cage option](#)" on page 75)
6. Remove the expansion slot blank:
  - o Primary PCIe riser cage

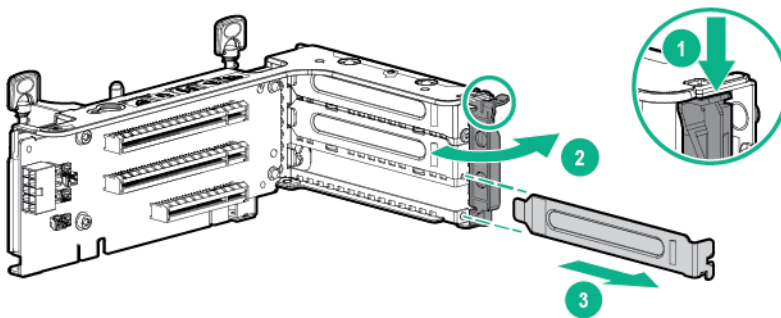



- Optional primary PCIe riser cage

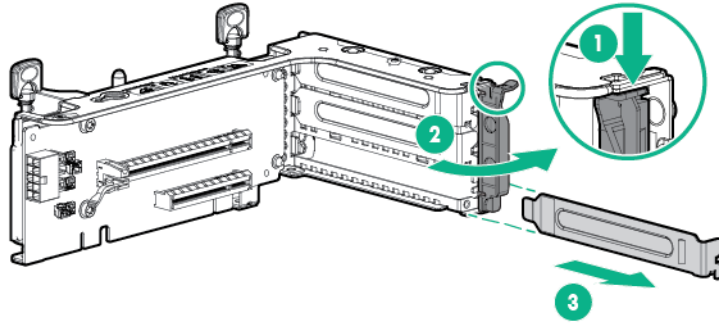

- Secondary PCIe riser cage

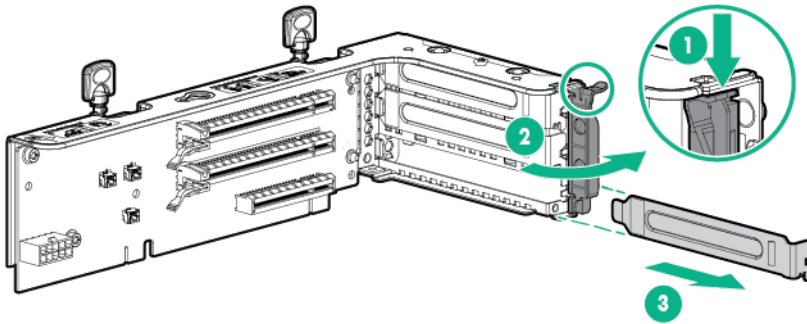

To replace the component, reverse the removal procedure.

## Installing an expansion board

1. Power down the server (on page 26).
2. Remove all power:
  - a. Disconnect each power cord from the power source.
  - b. Disconnect each power cord from the server.
3. Do one of the following:
  - Extend the server from the rack (on page 26).
  - Remove the server from the rack (on page 27).
4. Remove the access panel (on page 27).
5. Remove the PCI riser cage (on page 30).
6. Remove the expansion slot blank ("[Installing an expansion board](#)" on page 113).

7. Install the expansion board.

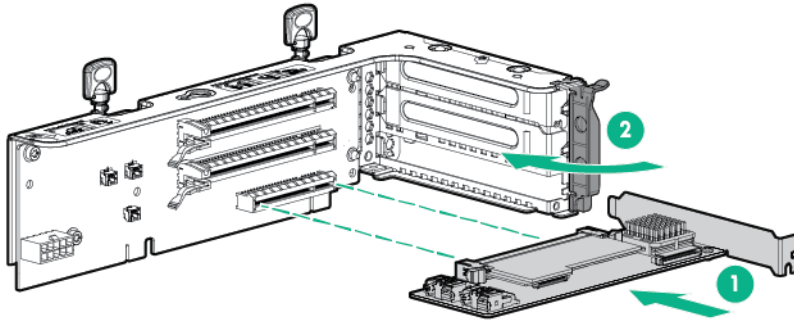

8. Connect any required internal or external cables to the expansion board. See the documentation that ships with the expansion board.
9. Install the PCI riser cage (on page 31).
10. Install the access panel (on page 28).
11. Install the server into the rack ("Installing the server into the rack" on page 39).
12. Connect each power cord to the server.
13. Connect each power cord to the power source.
14. Power up the server ("Powering up the server" on page 26).

## HPE H240 Smart HBA/P440, P840 Flexible Smart Array Controller



**CAUTION:** Hewlett Packard Enterprise recommends performing a complete backup of all server data before performing a controller or adapter installation or removal.

Before installing the controller, you must observe the following requirements:

- To ensure cables are connected correctly, observe the labels on the cable and component connectors.
- Be sure you have the latest firmware for the controllers, HBAs, and the expander card. To download the latest firmware, see the Hewlett Packard Enterprise website (<http://www.hpe.com/support/hpesc>).

To install the component:

1. Back up all server data.
2. Power down the server (on page 26).
3. Remove all power:
  - a. Disconnect each power cord from the power source.
  - b. Disconnect each power cord from the server.
4. Do one of the following:
  - Extend the server from the rack (on page 26).
  - Remove the server from the rack (on page 27).
5. Remove the access panel (on page 27).
6. Remove the PCI riser cage (on page 30).
7. Install the controller on the riser board:

- o H240 or P440

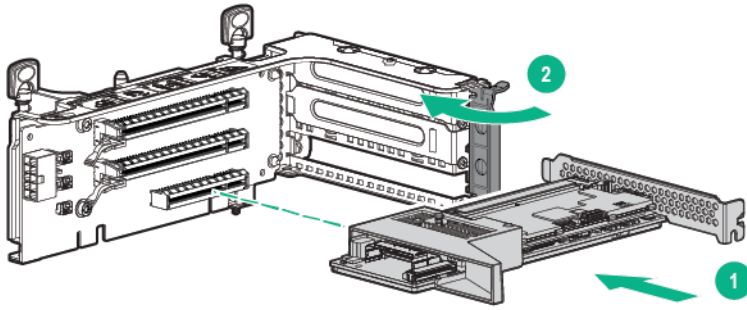

- o P840

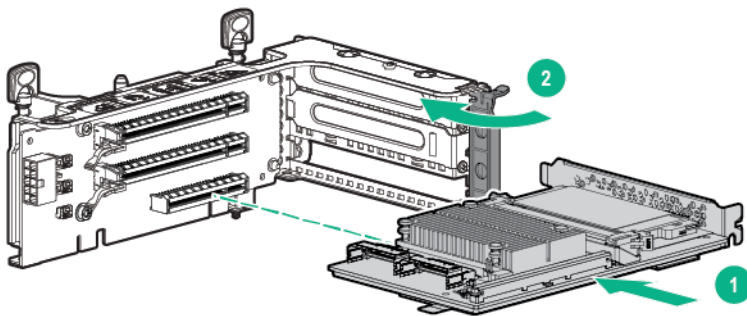

8. Install the riser board assembly:

- o H240 or P440

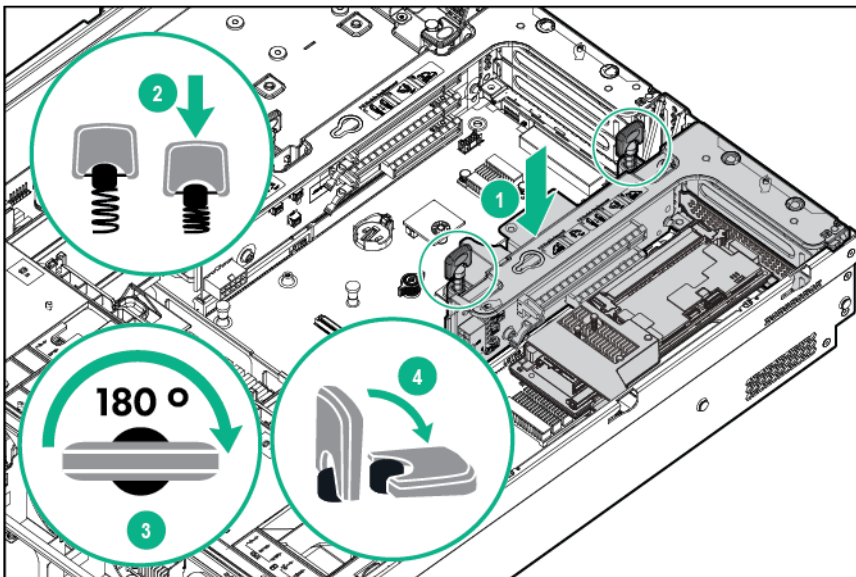

- o P840

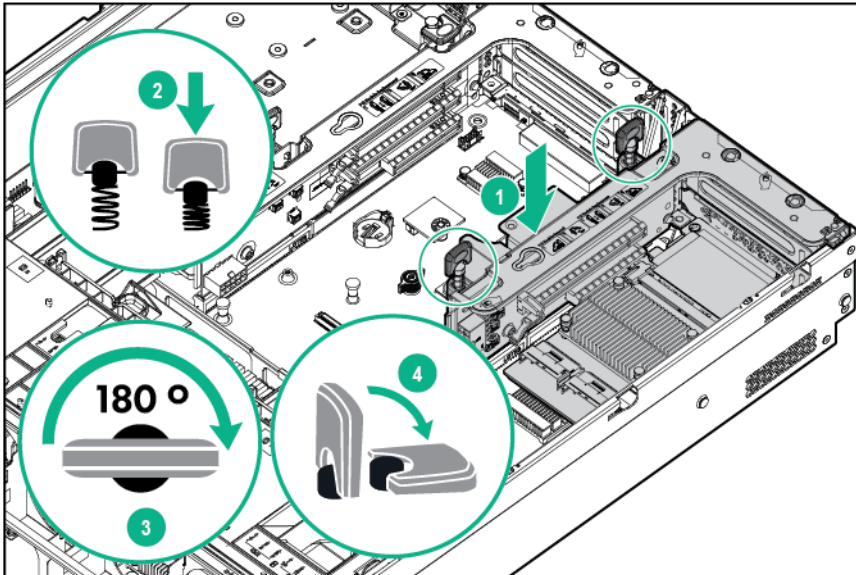

9. Connect the appropriate SAS cables. For more information, see Flexible Smart Array Controller cabling.
10. Install the air baffle (on page 33).
11. Install the access panel (on page 28).
12. Do one of the following:
  - a. Slide the server into the rack.
  - b. Install the server into the rack.
13. Connect each power cord to the server.
14. Connect each power cord to the power source.
15. Before powering on the system, be sure the HPE Smart Storage Battery ("Smart Storage Battery" on page 109) is installed.
16. Power up the server ("Powering up the server" on page 26).

## HPE P440ar/P840ar Flexible Smart Array Controller

**CAUTION:** Hewlett Packard Enterprise recommends performing a complete backup of all server data before performing a controller or adapter installation or removal.

Before installing the controller, you must observe the following requirements:

- To ensure cables are connected correctly, observe the labels on the cable and component connectors.
- Be sure you have the latest firmware for the controllers, HBAs, and the expander card. To download the latest firmware, see the Hewlett Packard Enterprise website (<http://www.hpe.com/support/hpesc>).

To install the component:

1. Back up all server data.
2. Power down the server (on page 26).
3. Remove all power:
  - a. Disconnect each power cord from the power source.

- b. Disconnect each power cord from the server.
4. Do one of the following:
  - o Extend the server from the rack (on page 26).
  - o Remove the server from the rack (on page 27).
5. Remove the access panel (on page 27).
6. Remove the air baffle (on page 32).
7. Install the controller:
  - o P440ar

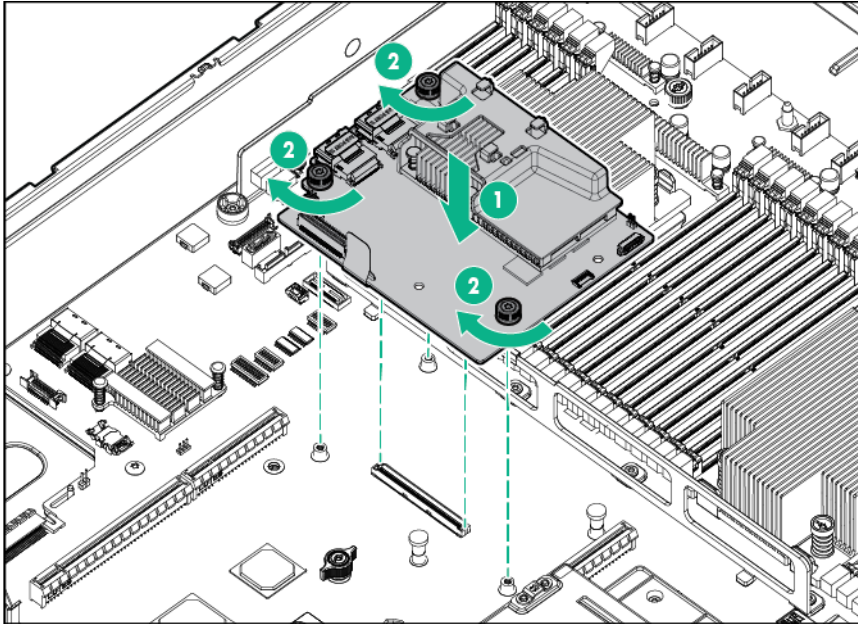

- o P840ar

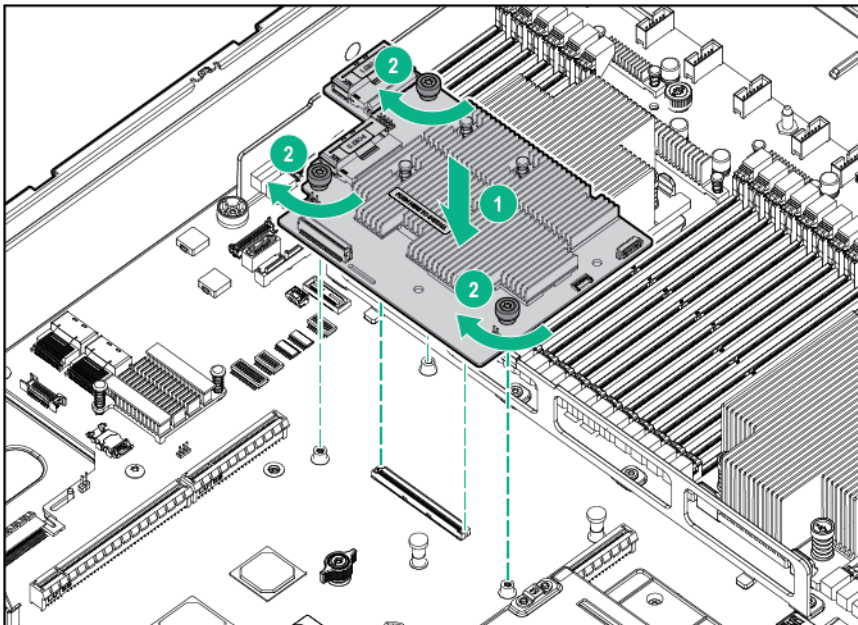

8. Connect the appropriate SAS cables. For more information, see Flexible Smart Array Controller cabling.
9. Install the air baffle (on page 33).

10. Install the access panel (on page 28).
11. Do one of the following:
  - a. Slide the server into the rack.
  - b. Install the server into the rack.
12. Connect each power cord to the server.
13. Connect each power cord to the power source.
14. Before powering on the system, be sure the HPE Smart Storage Battery ("Smart Storage Battery" on page 109) is installed.
15. Power up the server ("Powering up the server" on page 26).

## 12G SAS Expander Card

Before installing the 12G SAS Expander Card, observe the following requirements:

- The following components must be installed:
  - Storage controller
  - Drive cages:
    - For 24SFF drive configuration—Bay 1 and bay 2 8SFF front drive cages
    - For 12LFF drive configuration—12LFF front drive cage
    - For configurations using the rear drive cage—2SFF rear drive cage or 3LFF rear drive cage
- The preferred slot to install the SAS expander card is slot 3 of the primary PCI riser cage, if the slot is not occupied. It is not supported in the secondary PCI riser cage.
- To ensure cables are connected correctly, observe the labels on the cable and component connectors.
- Be sure you have the latest firmware for the controllers, HBAs, and the expander card. To download the latest firmware, see the Hewlett Packard Enterprise website (<http://www.hpe.com/support/hpesc>).
- Understand the required cable connections:
  - Group A—Controller to SAS expander card

Cable	Description	Connection to SAS expander	Connection to controller
776408-001	X4 Mini-SAS cable	Port 2	Port 2
776409-001	X4 Mini-SAS cable	Port 1	Port 1
781580-001	2 x4 Mini-SAS to x-8 Mini-SAS Y cable	Ports 1 and 2	Port 1

- Group B—SAS expander card to front LFF drive cage

Cable	Description	Connection to SAS expander	Connection to drive bay
747576-001	2 x4 mini-SAS cable	Port 3 Port 4	12 LFF Port 1 12 LFF Port 2
747577-001	x4 mini-SAS cable	Port 5	12 LFF Port 3

- Group C—SAS expander card to front SFF drive cages

Cable	Description	Connection to SAS expander	Connection to drive bay
776402-001	2 x4 Mini-SAS cable	Port 3 Port 4	8 SFF Bay 1 Port 1 8 SFF Bay 1 Port 2
781579-001	4 x4 Mini-SAS cable	Port 5 Port 6 Port 7 Port 8	8 SFF Bay 2 Port 1 8 SFF Bay 2 Port 2 8 SFF Bay 3 Port 1 8 SFF Bay 3 Port 2

- o Group D—SAS expander card to rear drive cage

Cable	Description	Connection to SAS expander	Connection to drive bay
776401-001	X4 Mini-SAS cable	Port 9	2SFF/3LFF

### 12G SAS Expander Card ports



To install the component:

1. Power down the server (on page 26).
2. Remove all power:
  - a. Disconnect each power cord from the power source.
  - b. Disconnect each power cord from the server.
3. Do one of the following:
  - o Extend the server from the rack (on page 26).
  - o Remove the server from the rack (on page 27).
4. Remove the access panel (on page 27).
5. Remove the air baffle (on page 32).
6. Remove the fan cage (on page 29).
7. Remove the primary PCI riser cage.



**IMPORTANT:** The 12G SAS Expander Card is not supported in the secondary PCI riser cage.

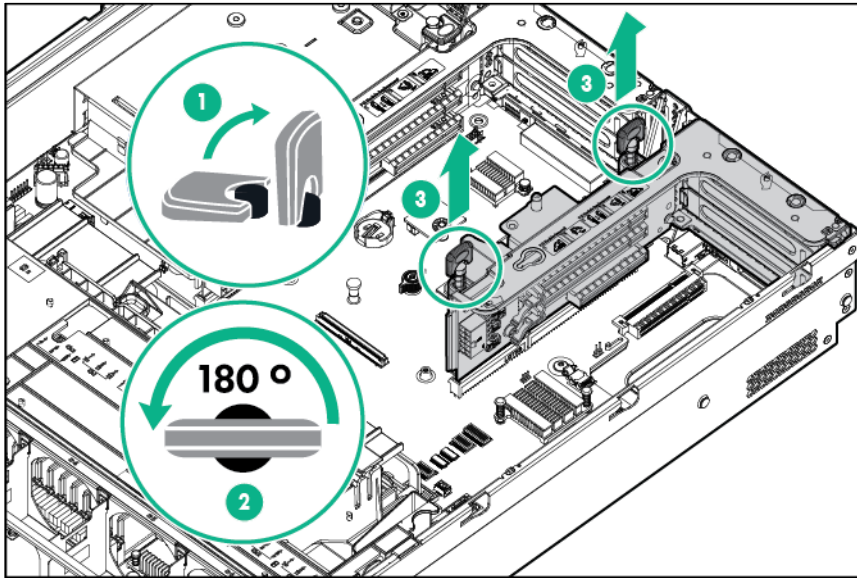

8. Remove the expansion slot blank from slot 3.

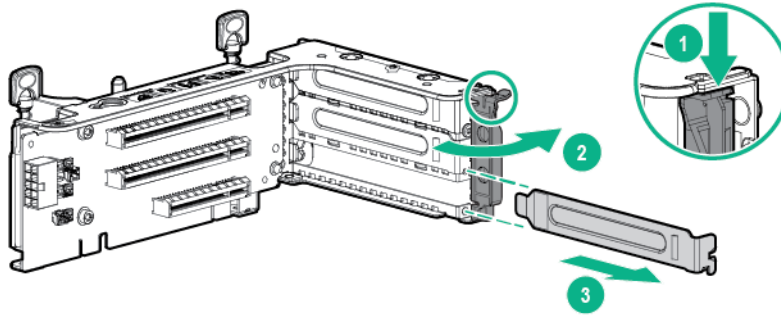

9. Using the labels on the cables to determine the correct connections, connect the cables to the SAS expander card:
- Depending on the ports on the controller, connect the appropriate controller cables from Group A to the SAS expander card.

Controller ports	Cable	SAS expander ports
2 x4 connectors	x4 Mini-SAS cable	Port 1
	x4 Mini-SAS cable	Port 2
1 x8 connector	2 x4 Mini-SAS to x8 Mini-SAS Y cable	Ports 1 and 2

- Depending on the drive configuration, connect the appropriate drive cage cables to the SAS expander card.

Drive configuration	Cable group	Cable	SAS expander ports
24 SFF	C	2 x4 Mini-SAS cable	Ports 3 and 4
		4 x4 Mini-SAS cable	Port 5
			Port 6
			Port 7
		Port 8	
12 LFF	B	2 x4 Mini-SAS cable	Ports 3 and 4



Drive configuration	Cable group	Cable	SAS expander ports
		x4 Mini-SAS cable	Port 5
2 SFF/3 LFF	D	x4 Mini-SAS cable	Port 9

10. Install the SAS expander card. The cables are not shown for clarity.  
The preferred slot to install the SAS expander card is slot 3 of the primary PCI riser cage.

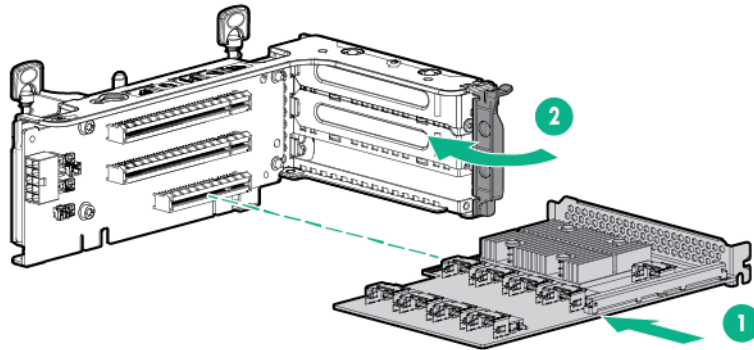

**IMPORTANT:** If using a PCI slot-based controller, install the controller in slot 1.

11. Install the PCI riser cage (on page 31).
12. Using the labels on the cables to determine the correct connections, connect the cables from the SAS expander card to the controller:
  - o HPE Flexible Smart Array Controller with 2 x4 connectors (Group A SAS cables)

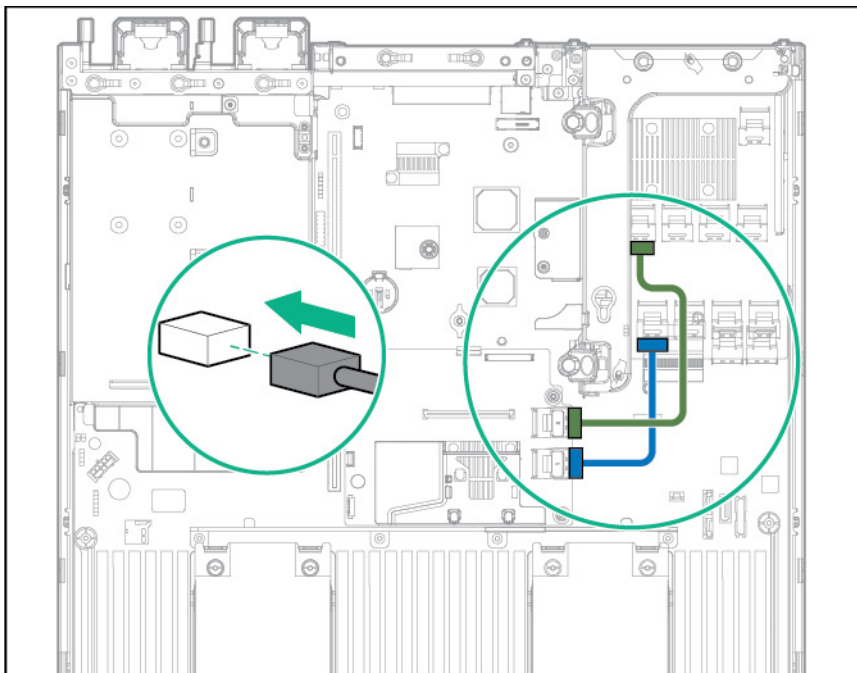

- o PCI slot-based Smart Array controller with x8 connector (Group A SAS cables)

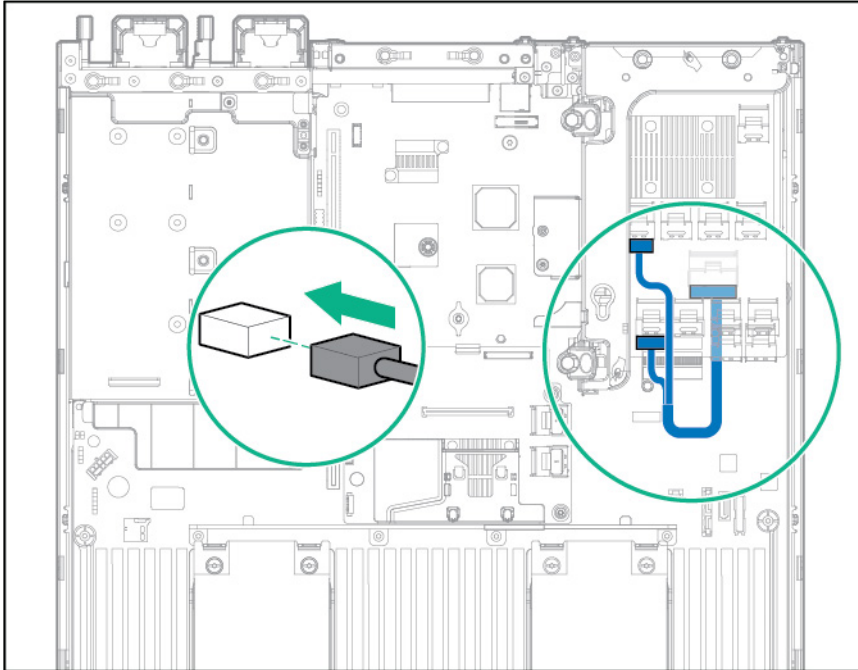

13. Connect the cables to the drive cage backplanes:

- o 24SFF drive backplanes (Group C SAS cables)

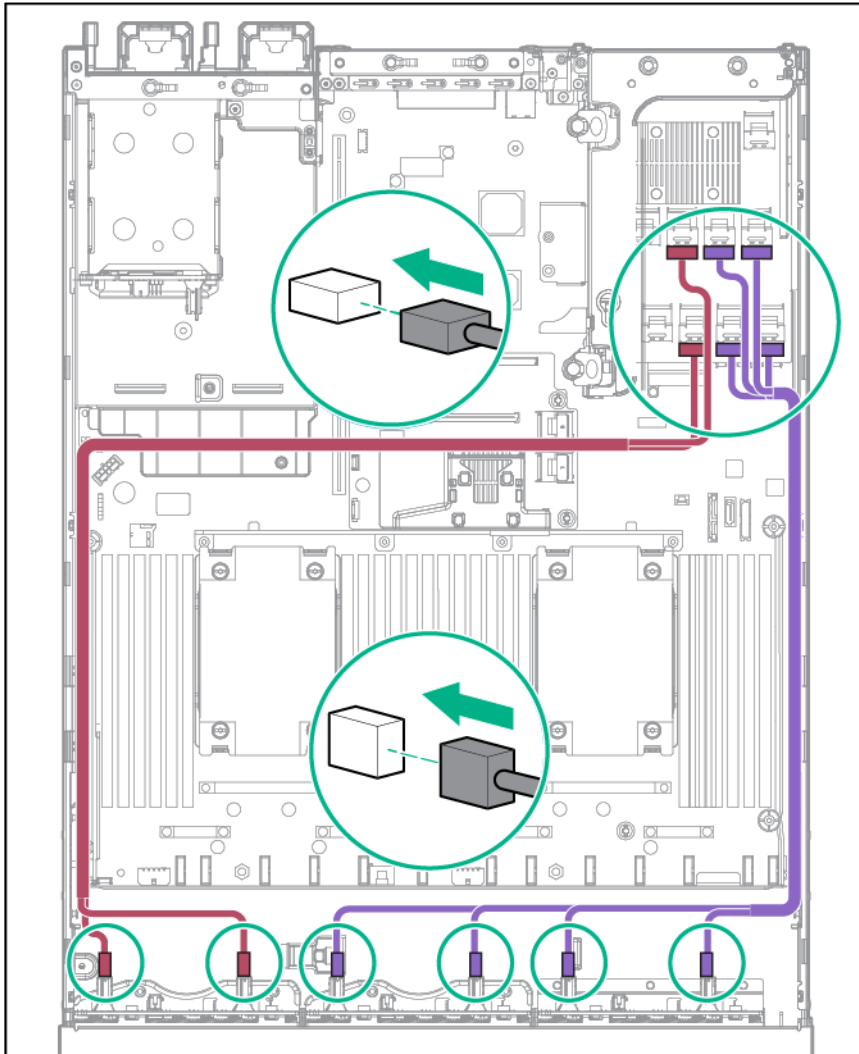

- o 12LFF drive backplanes (Group B SAS cables)

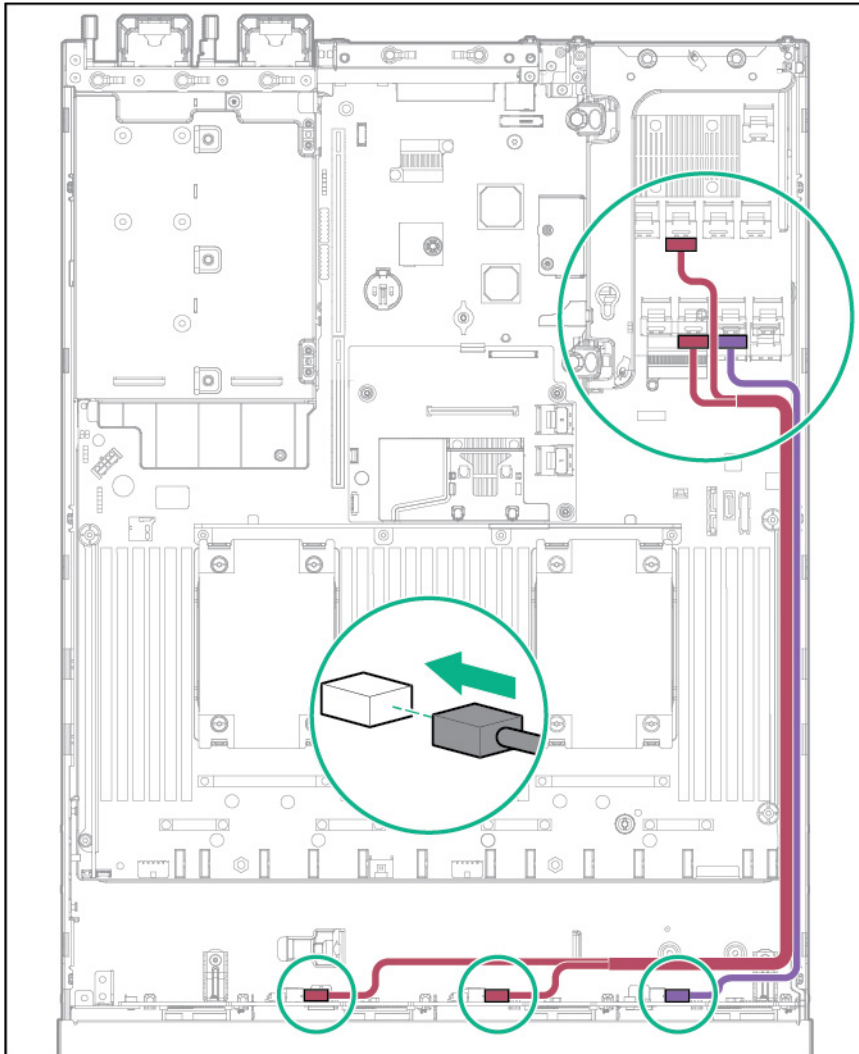

- o 2SFF or 3LFF rear cage drive backplane (Group D SAS cables)

The cabling is the same for both backplanes. In the following illustration, the 2SFF rear cage backplane is shown.

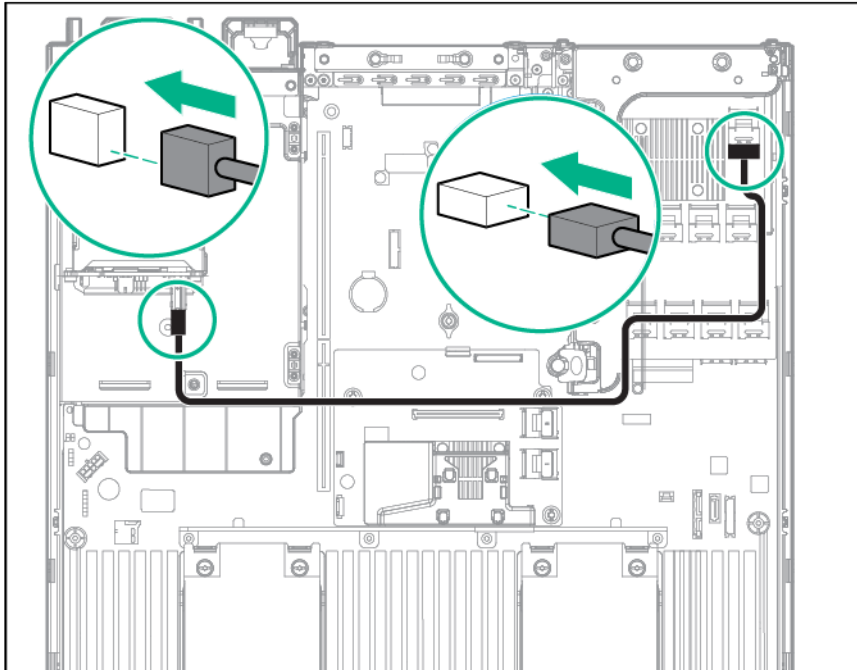

14. Install the fan cage.
15. Install the air baffle (on page 33).
16. Install the access panel (on page 28).
17. Install the server into the rack ("[Installing the server into the rack](#)" on page 39).
18. Connect each power cord to the server.
19. Connect each power cord to the power source.
20. Power up the server ("[Powering up the server](#)" on page 26).

## Rear serial port option

To install the component:

1. Power down the server (on page 26).
2. Remove all power:
  - a. Disconnect each power cord from the power source.
  - b. Disconnect each power cord from the server.
3. Do one of the following:
  - o Extend the server from the rack (on page 26).
  - o Remove the server from the rack (on page 27).
4. Remove the access panel (on page 27).

5. Remove the serial cable blank.

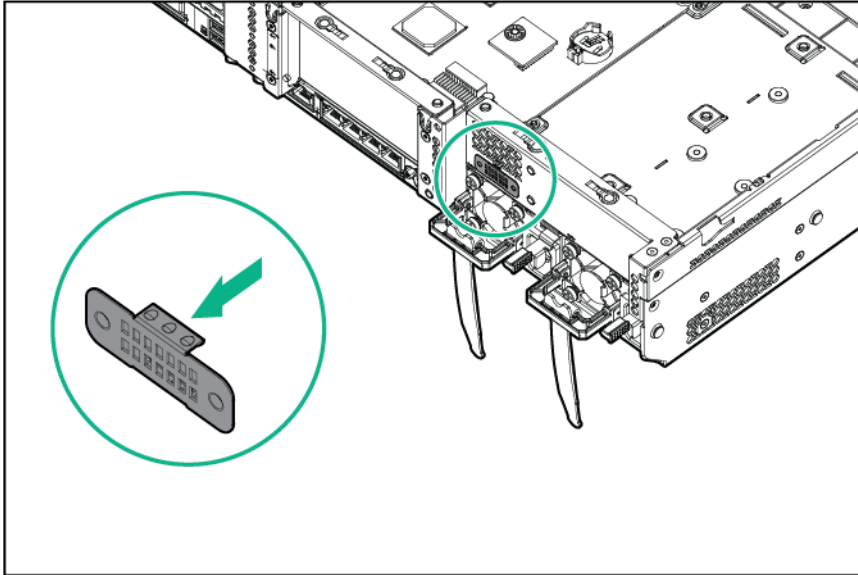

6. Connect the serial cable option. Then, remove the backing from the double-sided tape and press down where indicated.

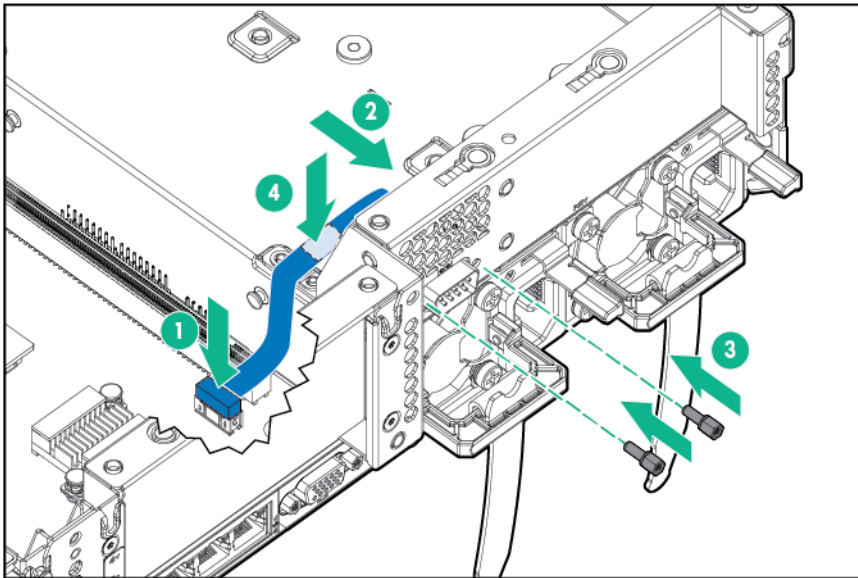

7. Install the access panel (on page 28).
8. Slide the server into the rack.
9. Connect each power cord to the server.
10. Connect each power cord to the power source.
11. Power up the server ("[Powering up the server](#)" on page 26).

## M.2 SSD Enablement Board option

The M.2 enablement board is supported in all 6 of the PCI slots on this server.

### Installing an SSD module on the M.2 SSD Enablement Board

1. Power down the server (on page 26).

2. Remove all power:
  - a. Disconnect each power cord from the power source.
  - b. Disconnect each power cord from the server.
3. Extend the server from the rack (on page 26).
4. Remove the access panel (on page 27).
5. Remove the PCIe riser cage ("Remove the PCIe riser cage" on page 30).
6. Remove the expansion slot blank ("Installing an expansion board" on page 113).



**IMPORTANT:** For management and monitoring of the SSD modules, use the HPE Smart Storage Administrator (<http://www.hpe.com/servers/ssa>).

7. Install the SSD module on the M.2 SSD enablement board.

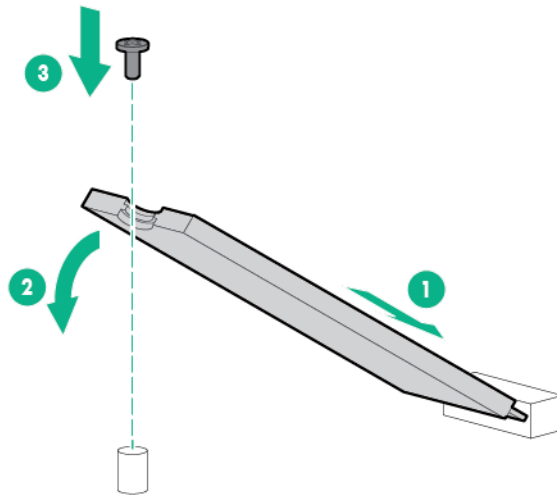

8. Install the M.2 SSD enablement board in any slot in the primary or secondary PCI riser cage ("Installing an M.2 SSD enablement board" on page 127).
9. Install the PCI riser cage (on page 31).
10. Install the access panel (on page 28).
11. Install the server into the rack ("Installing the server into the rack" on page 39).
12. Connect each power cord to the server.
13. Connect each power cord to the power source.
14. Power up the server ("Powering up the server" on page 26).

## Installing an M.2 SSD enablement board

1. Power down the server (on page 26).
2. Remove all power:
  - a. Disconnect each power cord from the power source.
  - b. Disconnect each power cord from the server.
3. Do one of the following:
  - o Extend the server from the rack (on page 26).
  - o Remove the server from the rack (on page 27).
4. Remove the access panel (on page 27).
5. Remove the PCIe riser cage ("Remove the PCIe riser cage" on page 30).

6. Remove the expansion slot cover.
7. Install the M.2 SSD enablement board into expansion any of the slots on the primary PCI riser or secondary PCI riser:
  - o 3-slot riser cage

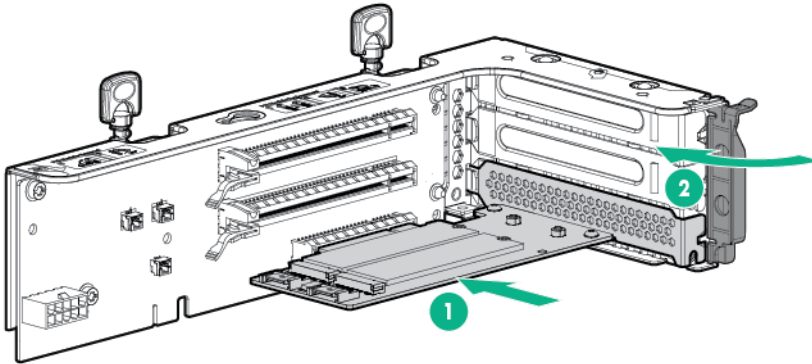

- o 2-slot riser cage

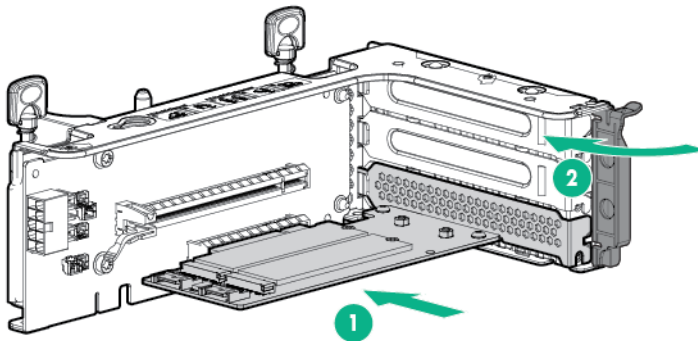

8. Connect the SATA cables from the M.2 SSD enablement board to the system board.
  - o M.2 SSD enablement board installed in the primary PCI riser cage

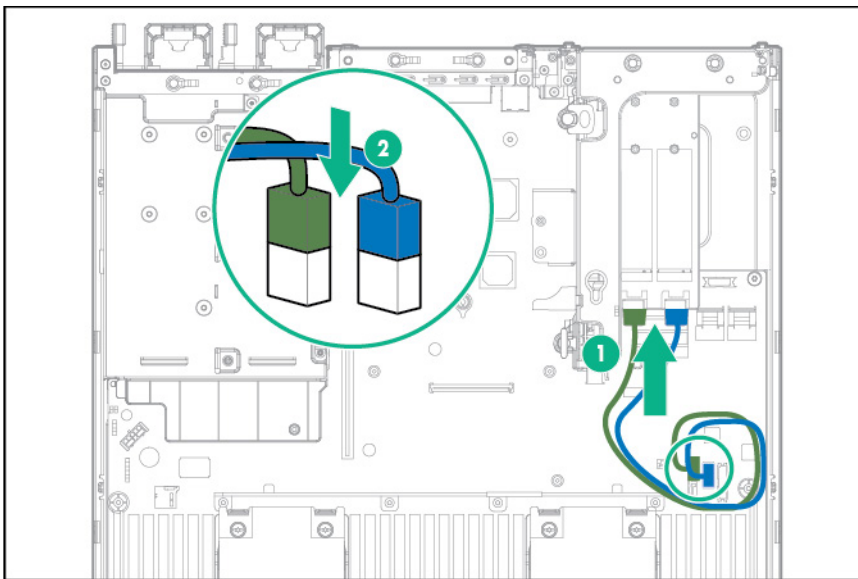



- o M.2 SSD enablement board installed in the secondary PCI riser cage

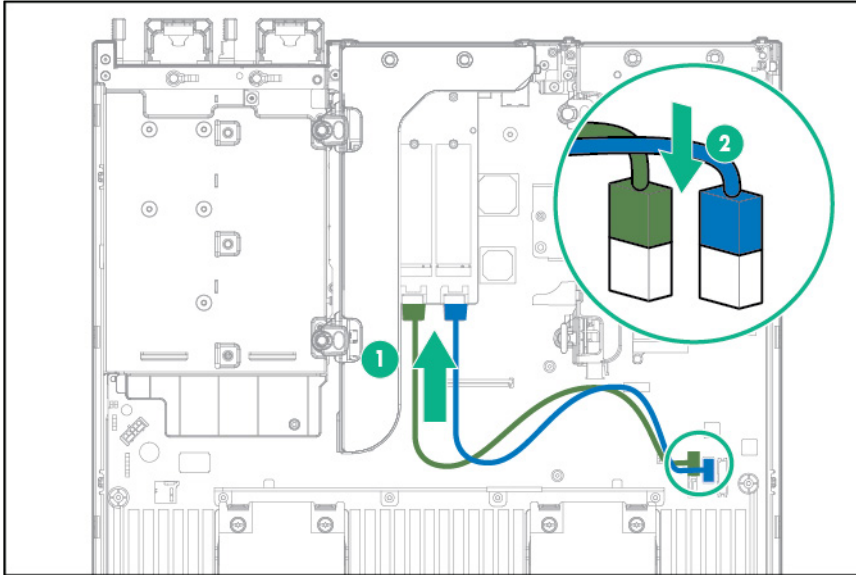

9. Install the PCI riser cage (on page 31).
10. Install the access panel (on page 28).
11. Install the server into the rack ("Installing the server into the rack" on page 39).
12. Connect each power cord to the server.
13. Connect each power cord to the power source.
14. Power up the server ("Powering up the server" on page 26).

## Dual 8Gb microSD Enterprise Midline USB device

This server supports the installation of the Dual 8Gb microSD Enterprise Midline USB device on the server internal USB connector.

This USB storage device contains a dual-SD card module that supports up to two SD, SDHC, or SDXC storage cards providing data redundancy through a mirrored RAID-1 configuration. This USB storage device connects to an internal USB connector and is configured upon boot.

To locate the internal USB connector, see "System board components (on page 17)." For more information, see the Dual 8Gb microSD EM USB storage device documentation on the Hewlett Packard Enterprise website (<http://www.hpe.com/support/8GBDualMicrosd ug en>).

## 750 W Flex Slot Hot Plug Battery Backup Module

The FSBBU is a self-contained unit with internal lithium-ion batteries that provide DC 12V backup power for servers when either the main bus utility power fails or the power supply is out of regulation.

You do not have to power down the server before removing or installing an FSBBU.

## Flex slot battery backup module configuration load support

The FSBBU module can be daisy chained to only one other FSBBU module. When AC power is lost to one server, then the loads of both servers will determine if the FSBBU will support the combined load.

Server #1 + FSBBU module load condition (%)	Server #2 + FSBBU module load condition (%)	Supported (Yes/No) where server #1 lost input AC power	Supported (Yes/No) where server #2 lost input AC power
10 (75W- 6.25A)	90 (675W- 56.25A)	Yes	No
20 (150W- 12.5A)	80 (600W- 50A)	Yes	No
30 (225W- 18.5A)	70 (525W- 43.5A)	Yes	No
40 (300W- 25A)	60 (450W- 37.5)	Yes	Yes
50 (375W- 31.25)	50 (375W- 31.25)	Yes	Yes
60 (450W- 37.5)	40 (300W- 25A)	Yes	Yes
70 (525W- 43.5A)	30 (225W- 18.5A)	No	Yes
80 ( 600W- 50A)	20 (150W- 12.5A)	No	Yes
90 (675W- 56.25A)	10 (75W- 6.25A)	No	Yes

## Installing the FSBBU

**CAUTION:** To prevent improper cooling and thermal damage, do not operate the chassis unless all bays are populated with a component or a blank.

To install the component:

1. Access the product rear panel (on page 28).
2. Remove the blank.

**WARNING:** To reduce the risk of personal injury from hot surfaces, allow the FSBBU or power supply blank to cool before touching it.

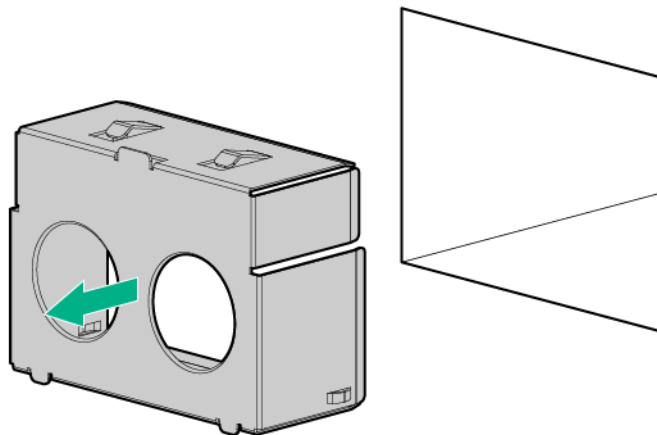

3. Press the battery check button located on the rear of the FSBBU module to check the battery condition before installing the unit into the power supply bay. To locate the battery check button and for more information on the FSBBU module LED status, see "Flex slot battery backup module LEDs and buttons (on page 15)."

4. Install the FSBBU module into the power supply bay until it clicks into place.

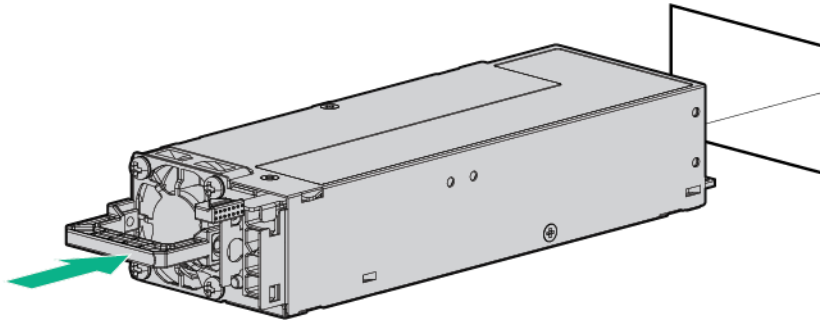

5. Connect multiple FSBBU units using a daisy chain configuration. A jumper cable (part number K9B28A) is required for a daisy chain configuration.

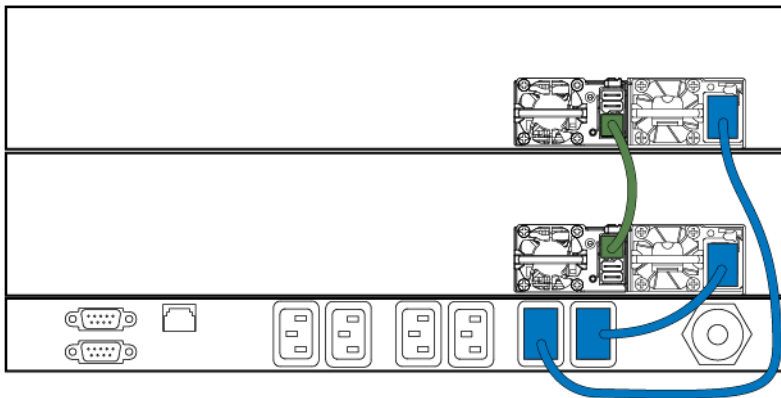

6. Charge the FSBBU module until the LED is solid green.

For more information about product features, specifications, options, configurations, and compatibility, see the product QuickSpecs on the Hewlett Packard Enterprise website (<http://www.hpe.com/info/qs>).

## HP Trusted Platform Module option

This server supports both TPM 1.2 and TPM 2.0. However, once the TPM version 1.2 is installed on the system board, it can no longer be upgraded to TPM version 2.0.

For more information about product features, specifications, options, configurations, and compatibility, see the product QuickSpecs on the Hewlett Packard Enterprise website (<http://www.hpe.com/info/qs>).

Use these instructions to install and enable a TPM on a supported server. This procedure includes three sections:

1. Installing the Trusted Platform Module board (on page 132).
2. Retaining the recovery key/password (on page 133).
3. Enabling the Trusted Platform Module (on page 134).

Enabling the TPM requires accessing BIOS/Platform Configuration (RBSU) in the UEFI System Utilities ("HPE UEFI System Utilities" on page 174).

TPM installation requires the use of drive encryption technology, such as the Microsoft Windows BitLocker Drive Encryption feature. For more information on BitLocker, see the Microsoft website (<http://www.microsoft.com>).

---

 **CAUTION:** Always observe the guidelines in this document. Failure to follow these guidelines can cause hardware damage or halt data access.

---

When installing or replacing a TPM, observe the following guidelines:

- Do not remove an installed TPM. Once installed, the TPM becomes a permanent part of the system board.
- When installing or replacing hardware, Hewlett Packard Enterprise service providers cannot enable the TPM or the encryption technology. For security reasons, only the customer can enable these features.
- When returning a system board for service replacement, do not remove the TPM from the system board. When requested, Hewlett Packard Enterprise Service provides a TPM with the spare system board.
- Any attempt to remove an installed TPM from the system board breaks or disfigures the TPM security rivet. Upon locating a broken or disfigured rivet on an installed TPM, administrators should consider the system compromised and take appropriate measures to ensure the integrity of the system data.
- When using BitLocker, always retain the recovery key/password. The recovery key/password is required to enter Recovery Mode after BitLocker detects a possible compromise of system integrity.
- Hewlett Packard Enterprise is not liable for blocked data access caused by improper TPM use. For operating instructions, see the encryption technology feature documentation provided by the operating system.

## Installing the Trusted Platform Module board

---

 **WARNING:** To reduce the risk of personal injury, electric shock, or damage to the equipment, remove the power cord to remove power from the server. The front panel Power On/Standby button does not completely shut off system power. Portions of the power supply and some internal circuitry remain active until AC power is removed.

---

 **WARNING:** To reduce the risk of personal injury from hot surfaces, allow the drives and the internal system components to cool before touching them.

---

To install the component:

1. Power down the server (on page 26).
2. Remove all power:
  - a. Disconnect each power cord from the power source.
  - b. Disconnect each power cord from the server.
3. Do one of the following:
  - Extend the server from the rack (on page 26).
  - Remove the server from the rack (on page 27).
4. Remove the access panel (on page 27).
5. Remove the PCI riser cage (on page 30).

---

 **CAUTION:** Any attempt to remove an installed TPM from the system board breaks or disfigures the TPM security rivet. Upon locating a broken or disfigured rivet on an installed TPM, administrators should consider the system compromised and take appropriate measures to ensure the integrity of the system data.

---

6. Install the TPM board. Press down on the connector to seat the board ("[System board components](#)" on page 17).

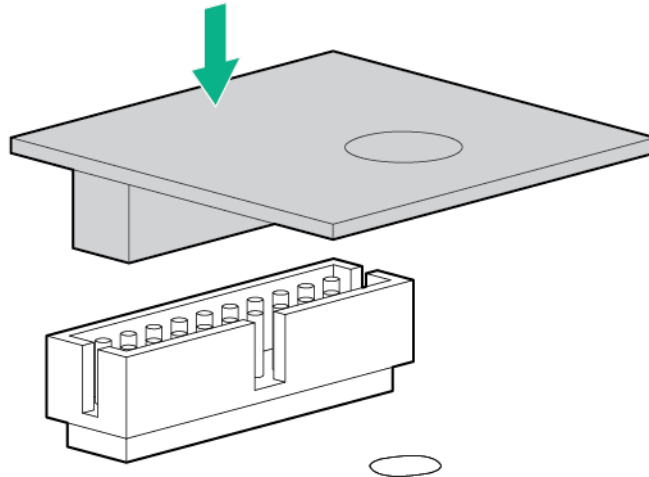

7. Install the TPM security rivet by pressing the rivet firmly into the system board.

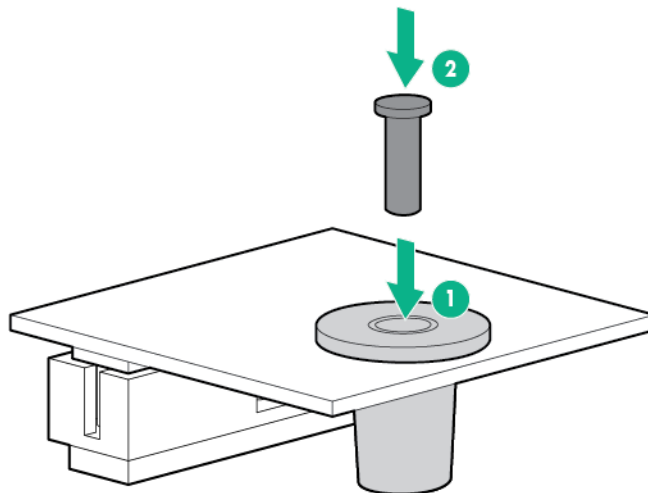

8. Install the PCI riser cage (on page 31).
9. Install the access panel (on page 28).
10. Install the server into the rack ("[Installing the server into the rack](#)" on page 39).
11. Power up the server ("[Powering up the server](#)" on page 26).

## Retaining the recovery key/password

The recovery key/password is generated during BitLocker setup, and can be saved and printed after BitLocker is enabled. When using BitLocker, always retain the recovery key/password. The recovery key/password is required to enter Recovery Mode after BitLocker detects a possible compromise of system integrity.

To help ensure maximum security, observe the following guidelines when retaining the recovery key/password:

- Always store the recovery key/password in multiple locations.
- Always store copies of the recovery key/password away from the server.

- Do not save the recovery key/password on the encrypted hard drive.

## Enabling the Trusted Platform Module

1. During the server startup sequence, press the **F9** key to access System Utilities.
2. From the System Utilities screen, select **System Configuration > BIOS/Platform Configuration (RBSU) > Server Security**.
3. Select **Trusted Platform Module Options** and press the **Enter** key.
4. Select **Enabled** to enable the TPM and BIOS secure startup. The TPM is fully functional in this mode.
5. Press the **F10** key to save your selection.
6. When prompted to save the change in System Utilities, press the **Y** key.
7. Press the **ESC** key to exit System Utilities. Then, press the **Enter** key when prompted to reboot the server.

The server then reboots a second time without user input. During this reboot, the TPM setting becomes effective.

You can now enable TPM functionality in the OS, such as Microsoft Windows BitLocker or measured boot.



---

**CAUTION:** When a TPM is installed and enabled on the server, data access is locked if you fail to follow the proper procedures for updating the system or option firmware, replacing the system board, replacing a hard drive, or modifying OS application TPM settings.

---

For more information on firmware updates and hardware procedures, see the *HP Trusted Platform Module Best Practices White Paper* on the Hewlett Packard Enterprise Support Center website (<http://www.hpe.com/support/hpesc>).

For more information on adjusting TPM usage in BitLocker, see the Microsoft website (<http://technet.microsoft.com/en-us/library/cc732774.aspx>).

# Cabling

## Cabling overview

This section provides guidelines that help you make informed decisions about cabling the server and hardware options to optimize performance.



**CAUTION:** When routing cables, always be sure that the cables are not in a position where they can be pinched or crimped.

## Two-bay SFF drive cage option cabling

### 2 SFF drive bay option rear installation

1. Connect the power cable using one of the following connections:
  - o **Single cable connection with 12 LFF drive configuration in the front**

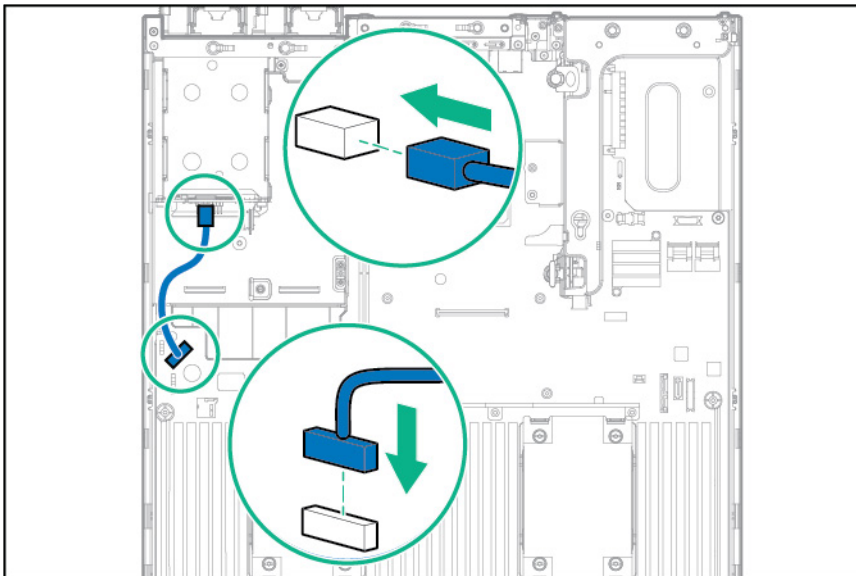

- Y cable connection with 24 SFF drive configuration in front

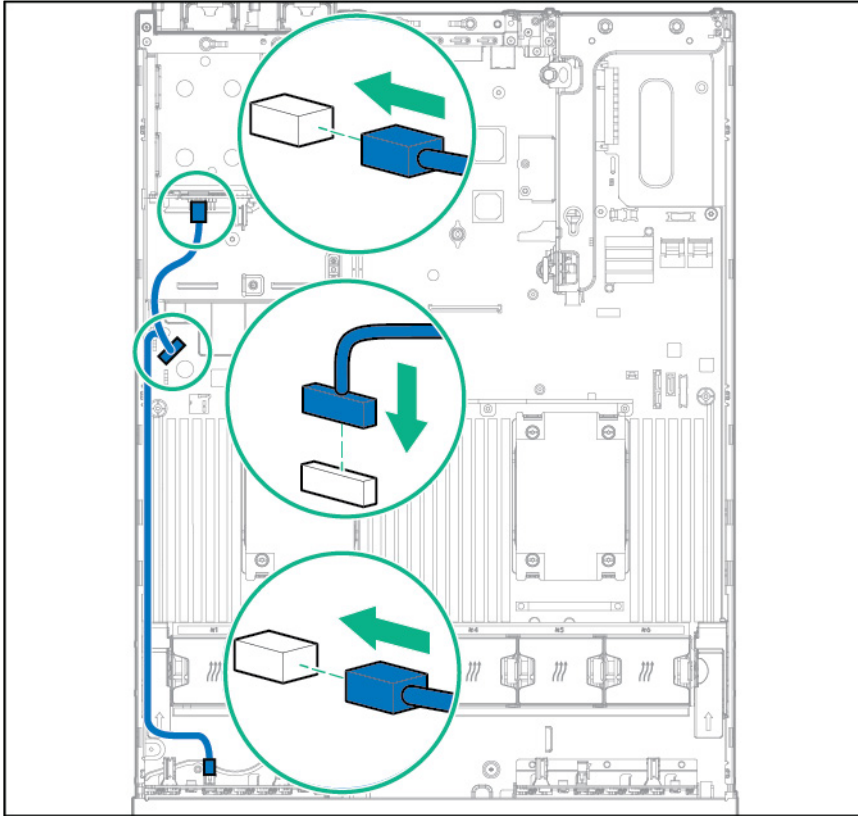

2. Connect the data cable using one of the following connections:

- **Connect to the onboard x4 SATA connector**

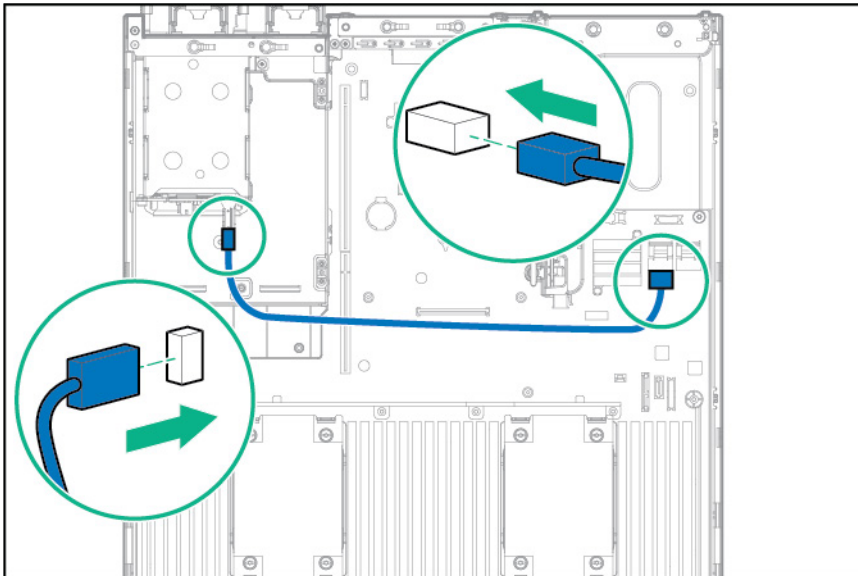



- **Connect to the x2 SATA port and optical disk drive connector**

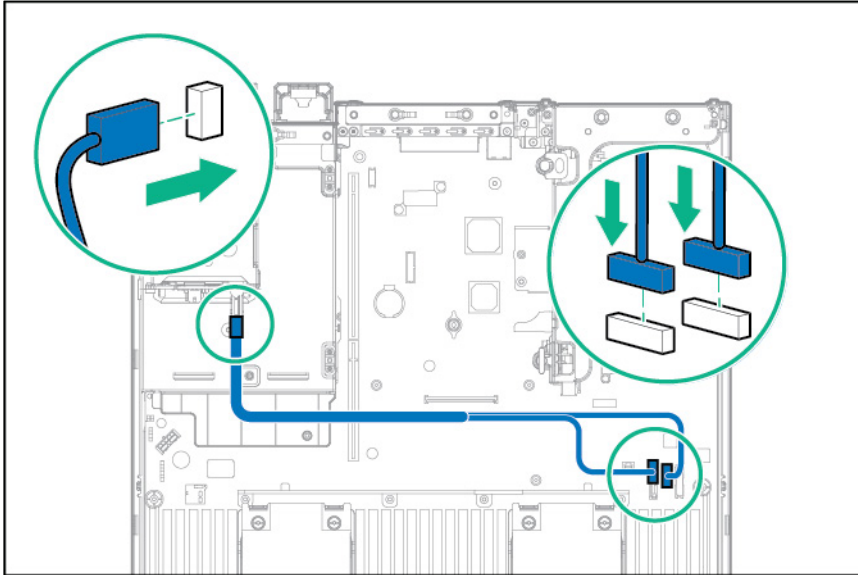

- **Connect to a PCI expansion board**

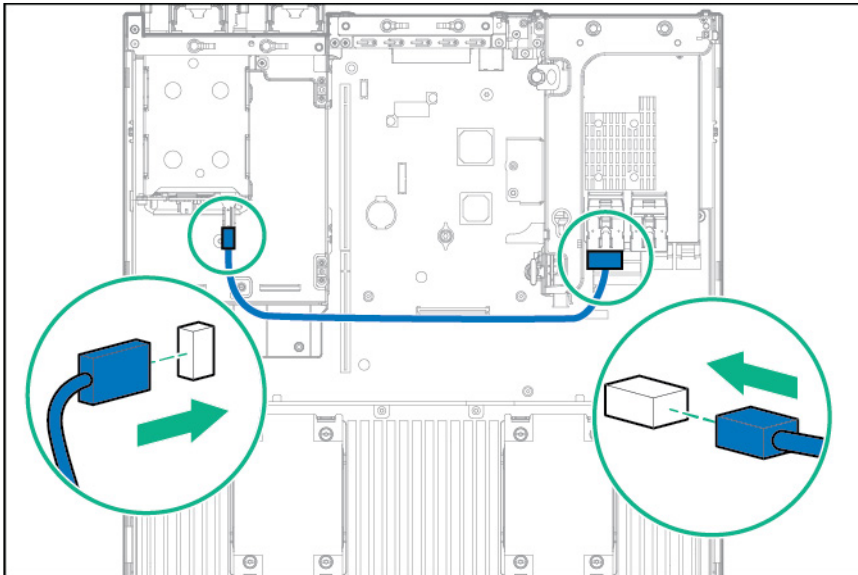

- **Connect to a PCI expansion board and the 12 LFF drive backplane**

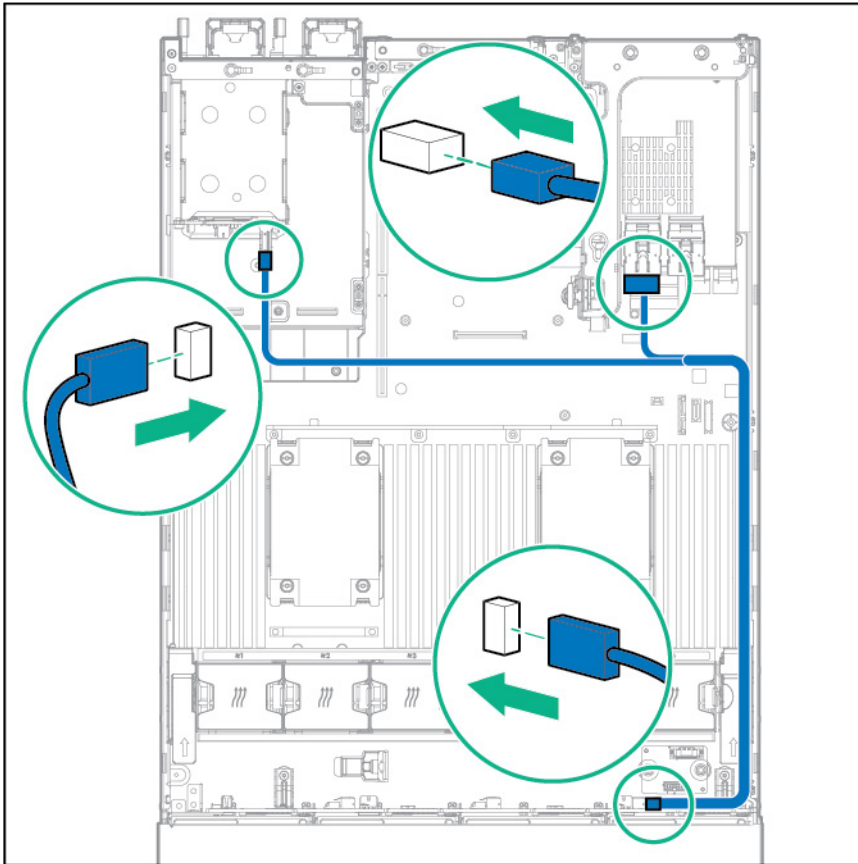

- **Connect to an HPE 12G SAS Expander Card**

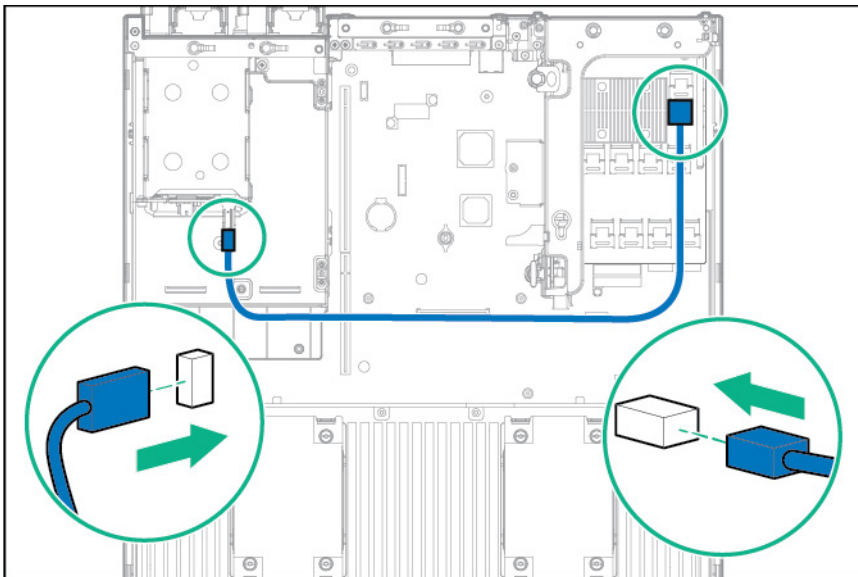

# Three-bay LFF rear drive cage cabling

- 1. Connect the power cable.

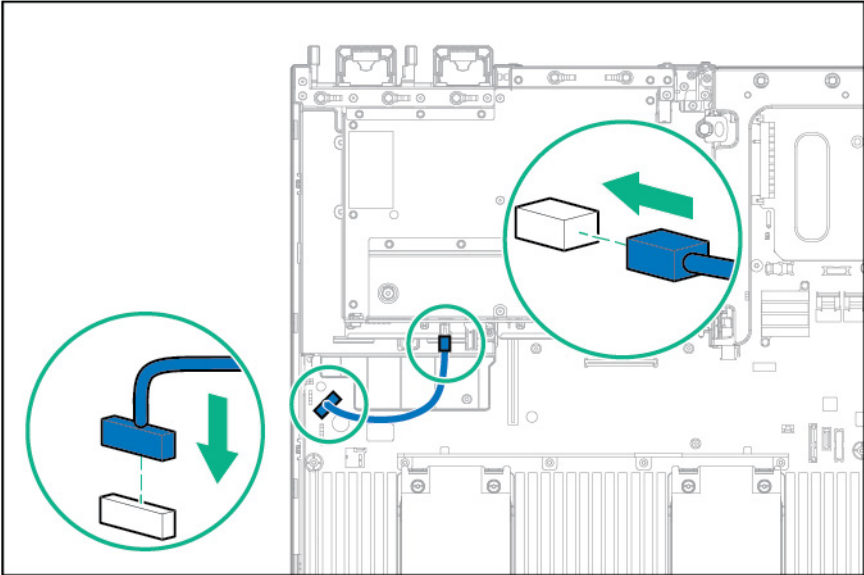

- 2. Connect the data cable using one of the following connections:
  - o **Connect to onboard SATA connectors**

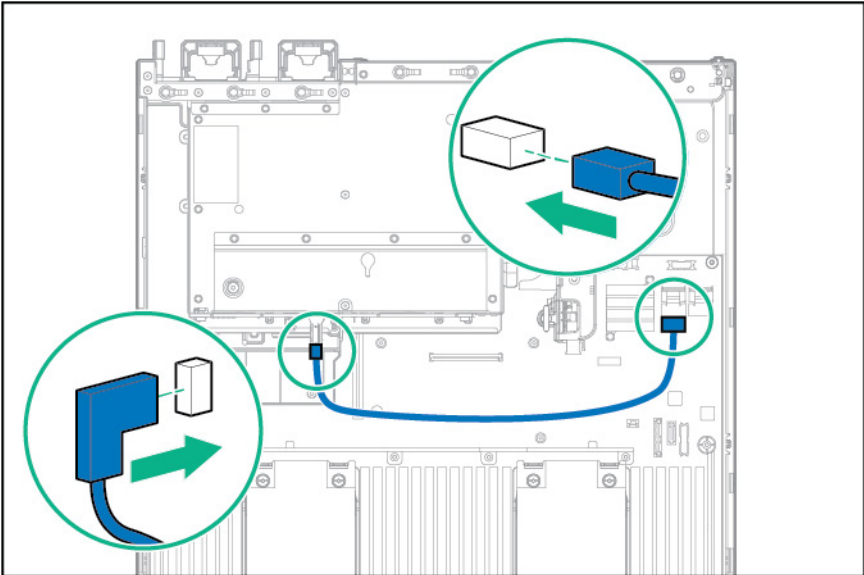

- **Connect to a PCI expansion board**

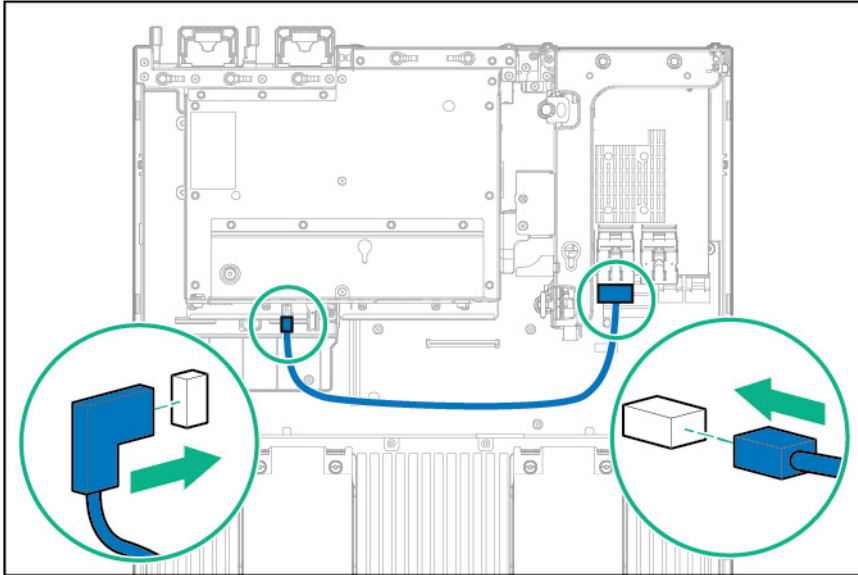

- **Connect to a PCI expansion board and the 12 LFF drive backplane**

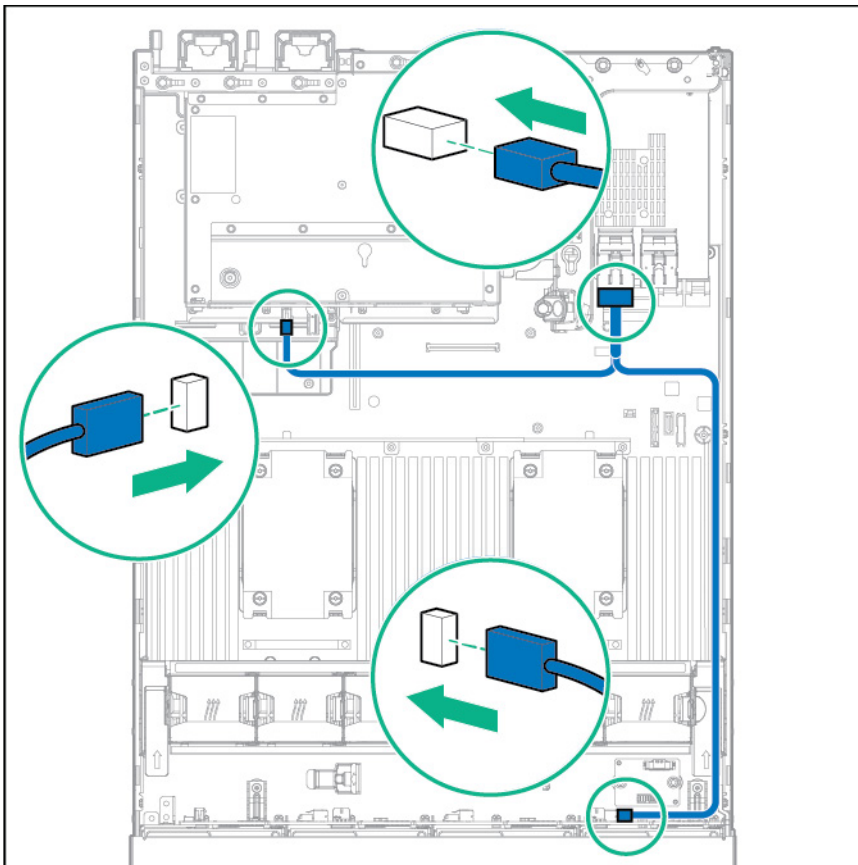

- Connect to an HPE 12G SAS Expander Card

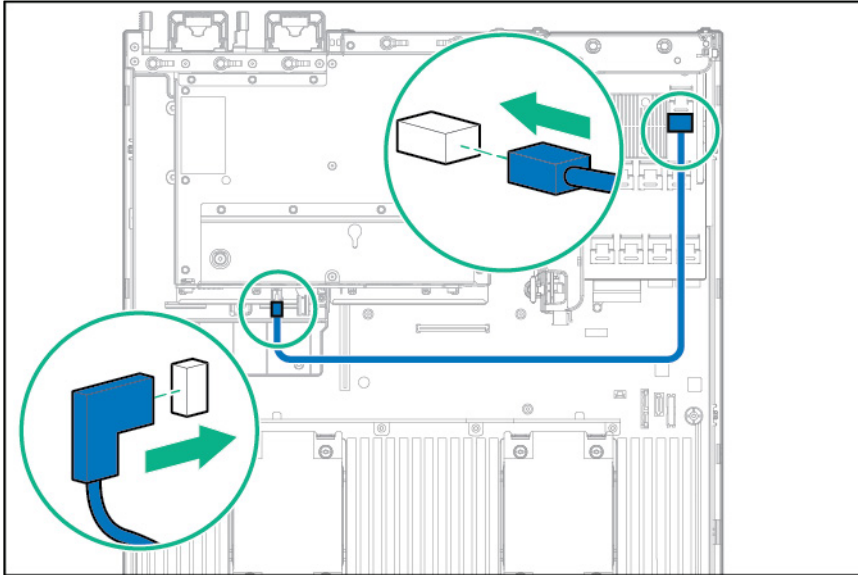

## Eight-bay SFF front drive cage cabling

### Bay 1 installation

1. Connect the power cable using one of the following connections:
  - **Single cable connection**

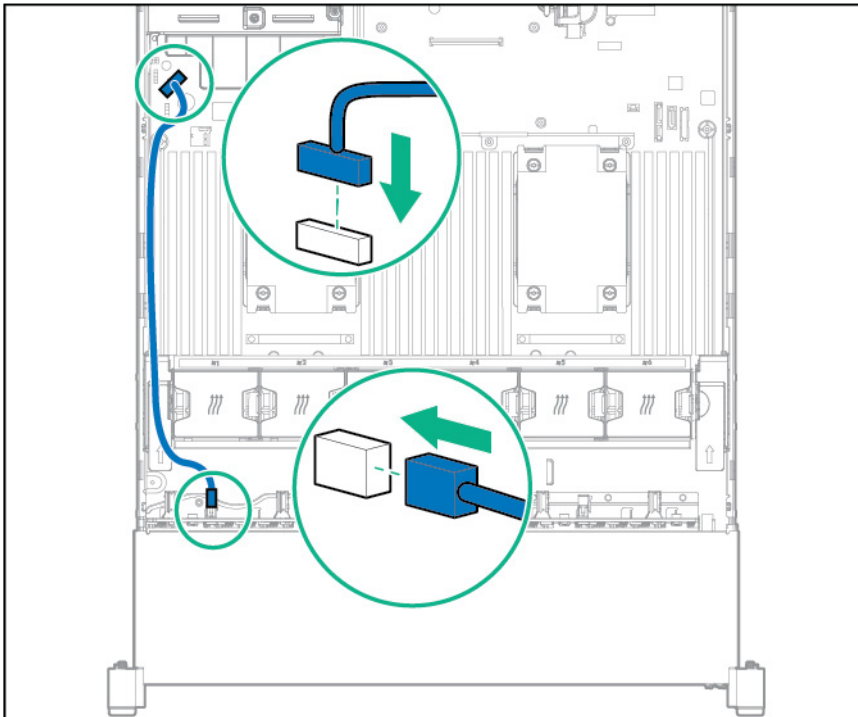

- Y cable connection if the two-bay SFF drive cage option is installed in the rear bay

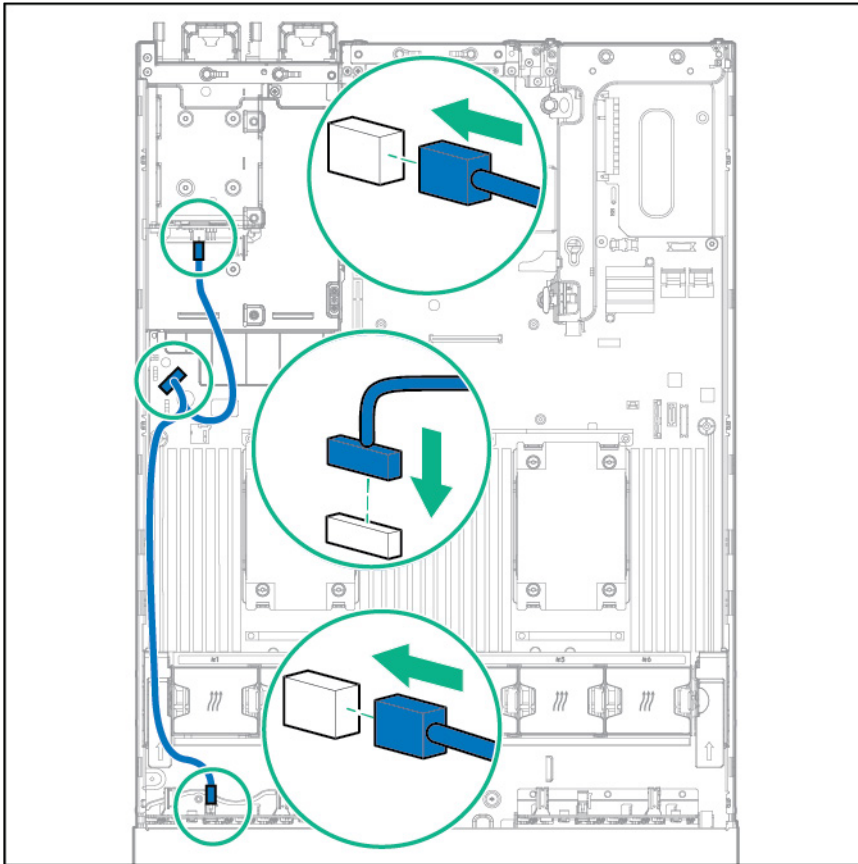

2. Connect the data cable using one of the following connections:

- **Connect to a PCI expansion board**

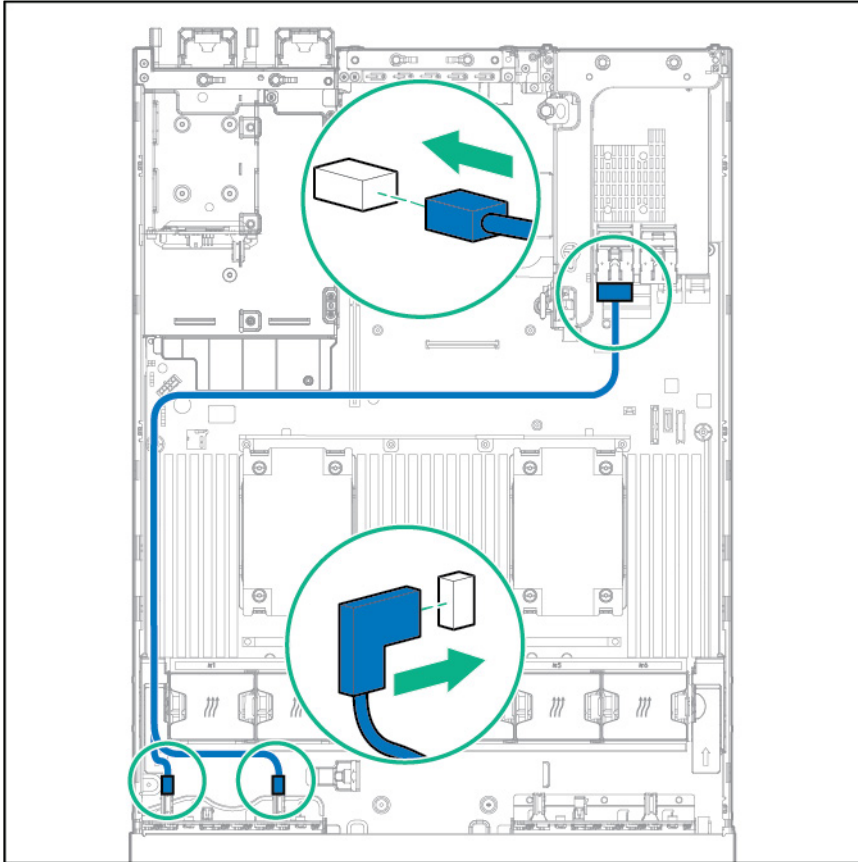

- Connect to an HPE 12G SAS Expander Card

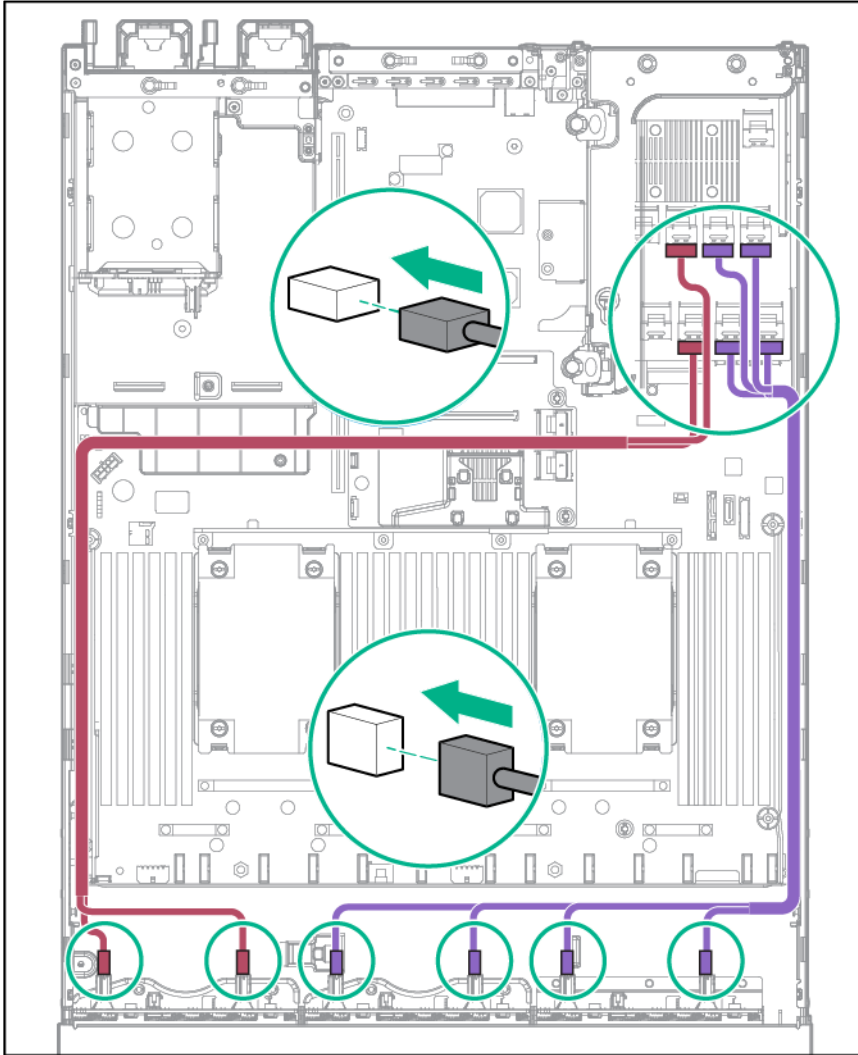

**Bay 2 installation**



1. Connect the power cable.

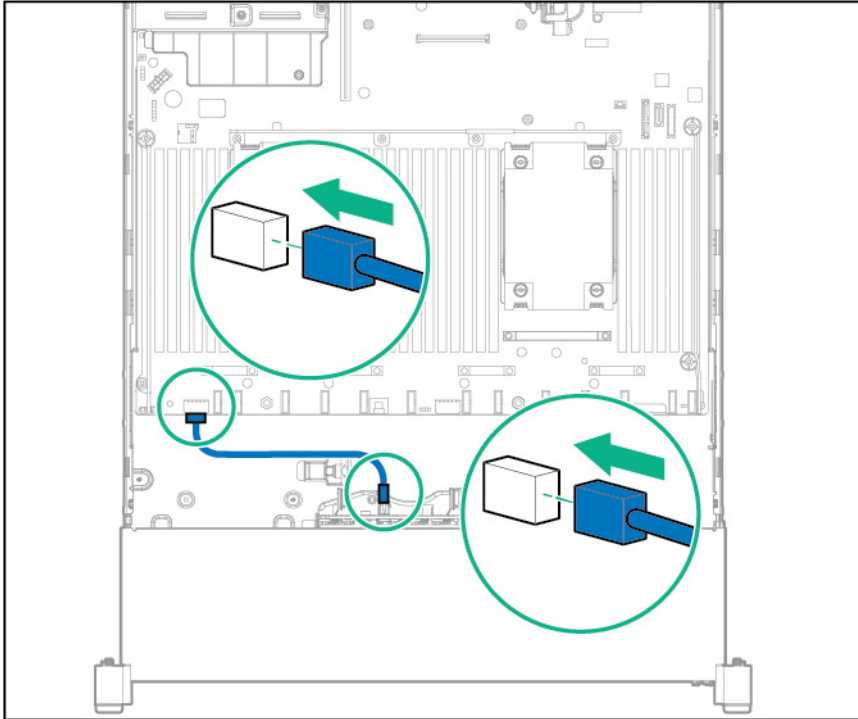

2. Connect the data cable using one of the following connections:
  - o **Connect to a PCI expansion board**

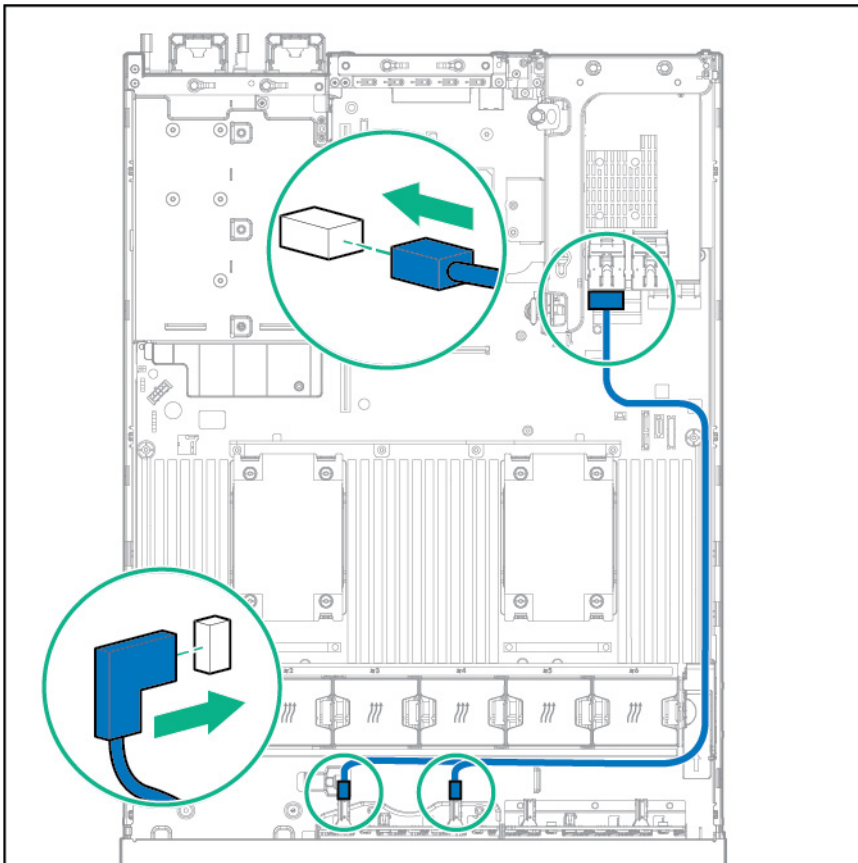

- **Connect to an HPE 12G SAS Expander Card**

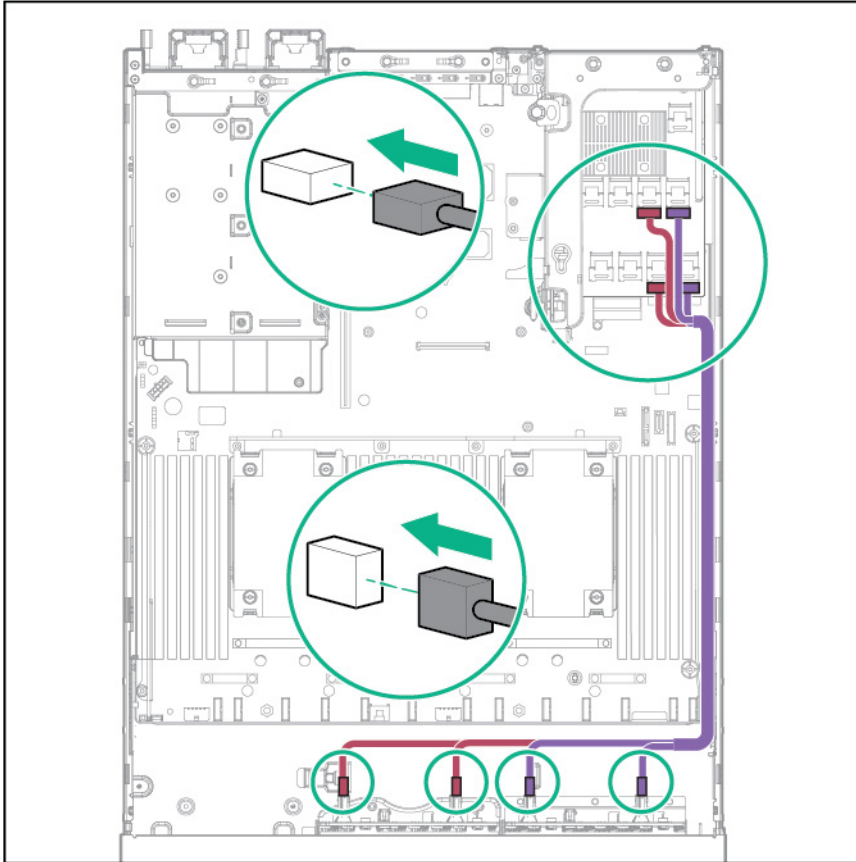

## Express Bay Enablement Option cabling options

The Express Bay Enablement option has several options for cabling, depending on the configuration:

- 8SFF drive cage installed in bay 1
- 8SFF drive cage installed in bay 1 and 2SFF drives in the rear of the server
- Drive bay 1 is empty
- 8SFF drive cage installed in bay 1 and 2 SFF drives in the front of the server

# 8SFF drive cage installed in bay 1

Connect using the 8SFF drive cage power cable (776399-001).

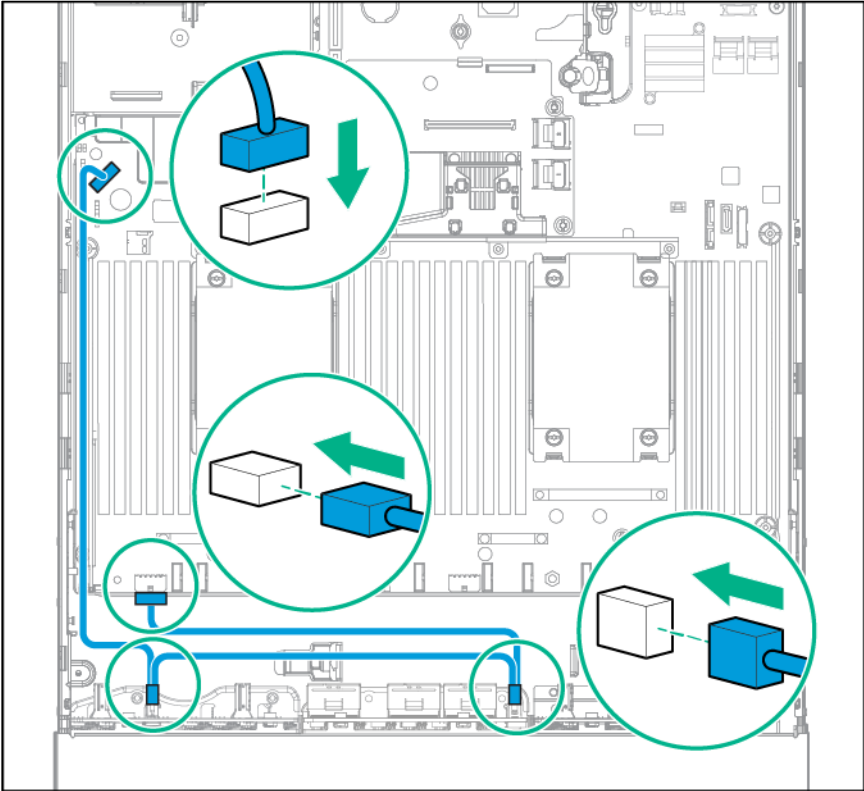

# 8SFF drive cage installed in bay 1 and 2SFF drives in the rear of the server

Connect using the 8SFF drive cage power cable (776399-001) and the 2SFF drives-rear power cable (776400-001).

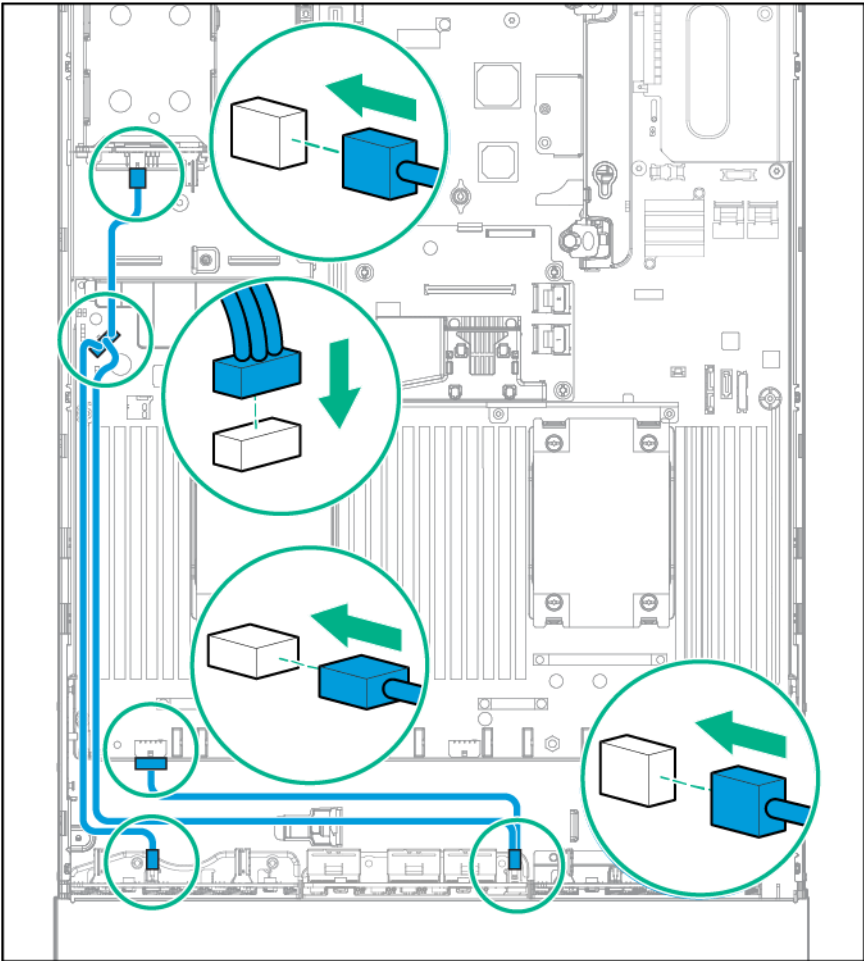

# Drive bay 1 is empty

Connect using the NVMe power cable (776392-001).

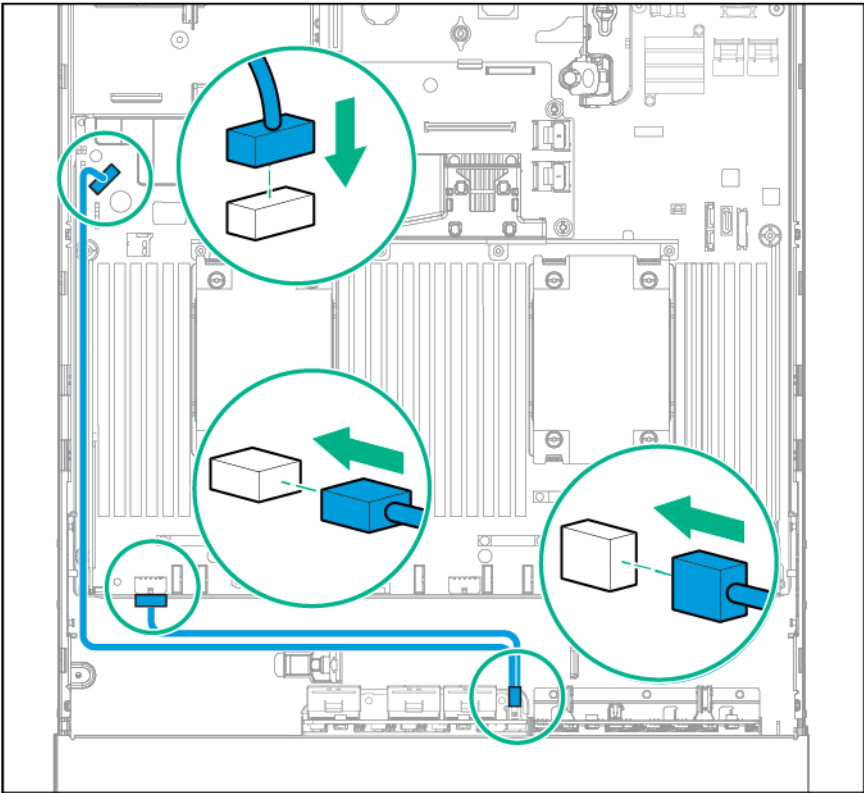

## 8SFF drive cage installed in bay 1 and 2 SFF drives in the front of the server

Connect using the 8SFF drive cage power cable (776399-001) and the 2SFF drives-front power cable (795156-001).

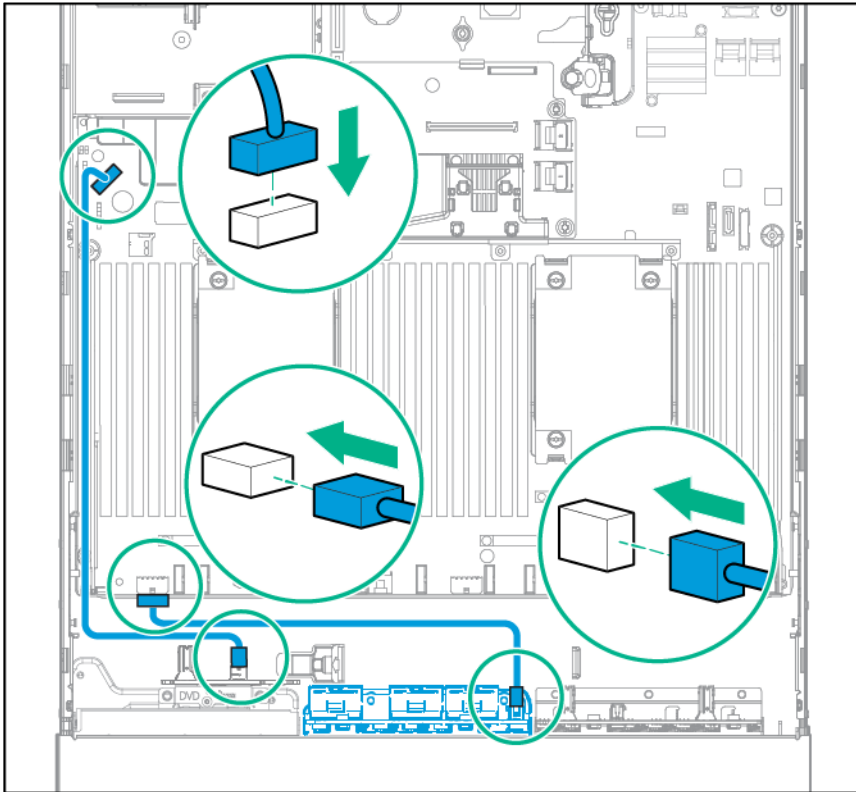

## Host Bus Adapter and Controller cabling

The server supports the HPE H240 Smart Host Bus Adapter and the following controllers:

- HPE Smart Array P440 Controller
- HPE Smart Array P440ar Controller
- HPE Smart Array P840 Controller
- HPE Smart Array P840ar Controller

For more information about supported controller, features, specifications, options, configurations, and compatibility, see the product QuickSpecs on the Hewlett Packard Enterprise website (<http://www.hpe.com/info/qs>).

# HPE H240 Smart Host Bus Adapter/Smart Array P440 Controller cabling

- 8SFF drive cages are installed in bays 1 and 2, and 2SFF drives and VGA/USB are installed in the front of the server (H240 HBA only) — Connect the bay 2 8SFF drive cage cable, the 2SFF drive Mini-SAS cable, and the VGA/USB cable to the H240 HBA.

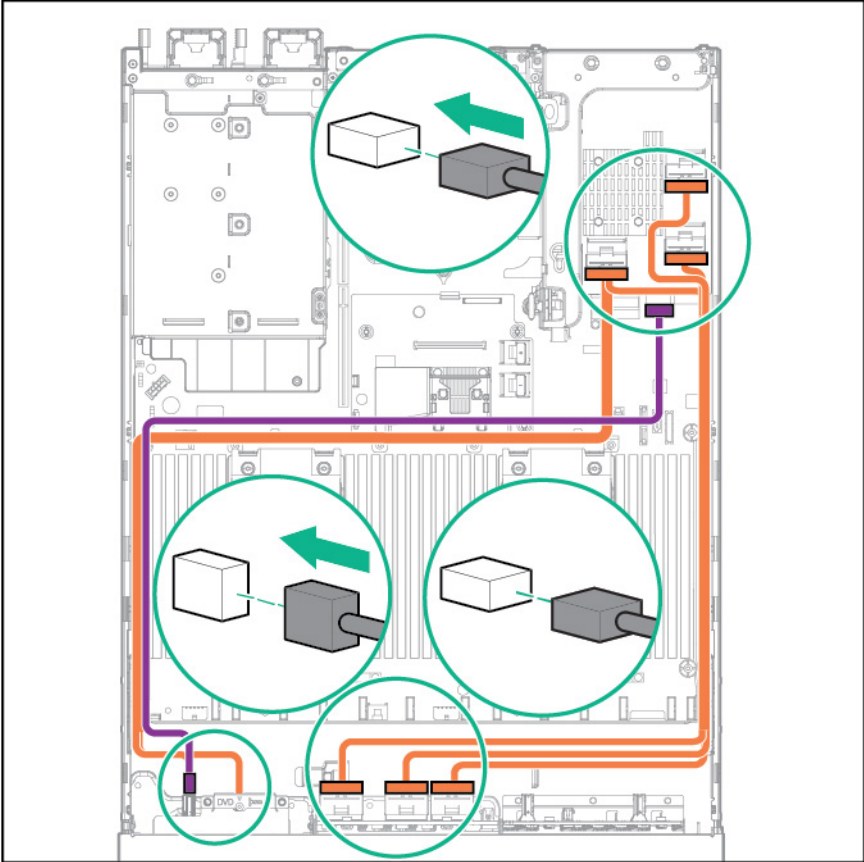

- 8SFF drive cage is installed in bay 2, 6NVMe drives are installed in bay 1, and 2SFF drives and VGA/USB are installed in the front of the server — Connect the 6NVMe data cable, VGA/USB cable, and the front 2SFF Mini-SAS cable to the H240 HBA/P440 controller.

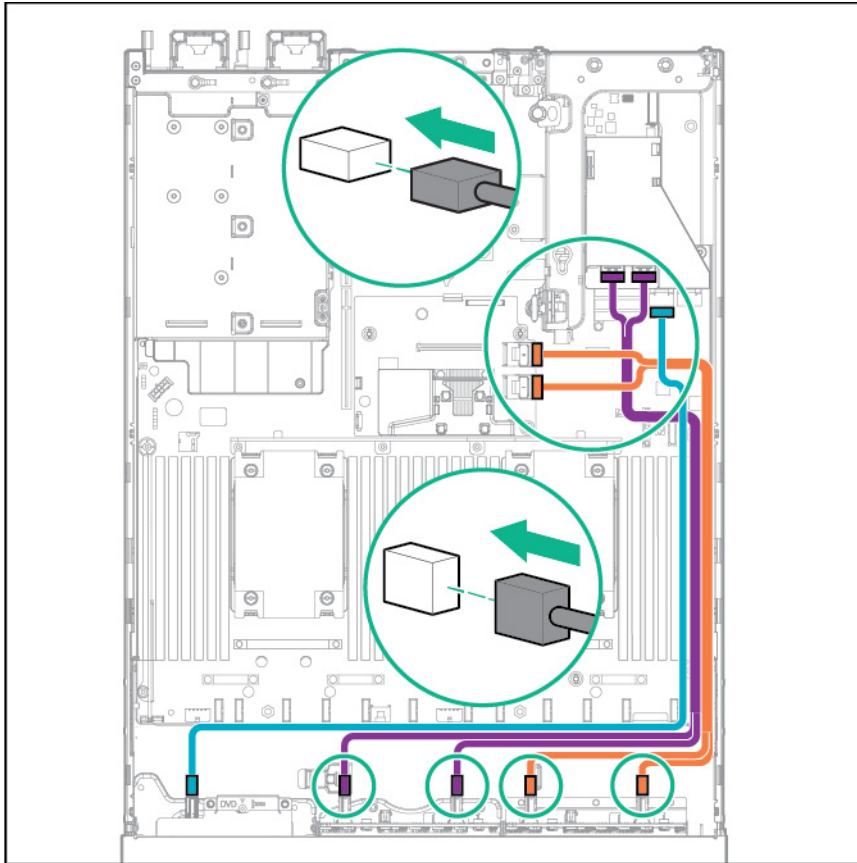



- 12LFF drive cage is installed in the front, and 3LFF drives are installed at the rear of the server — Connect a 12LFF Mini-SAS cable and the 3LFF Mini-SAS cable to the H240 HBA/P440 controller.

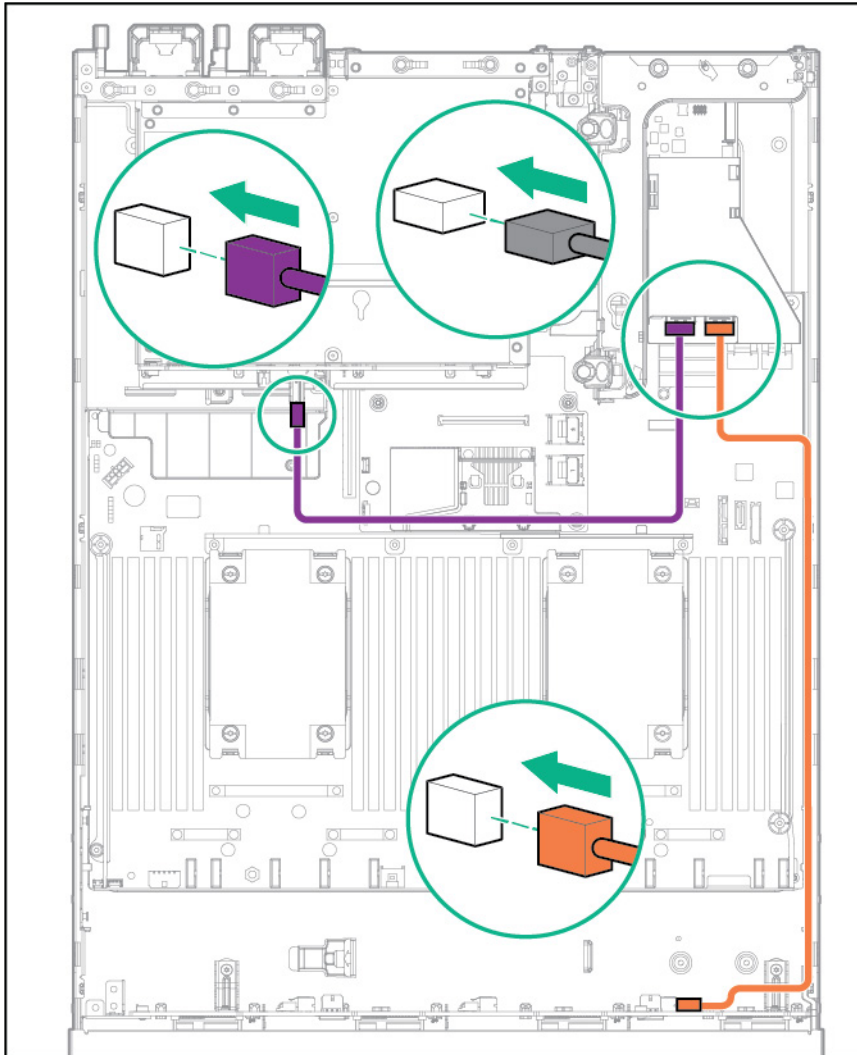

# HPE Smart Array P840 Controller cabling

- 24SFF drive configuration — Connect bay 1 and bay 2 Mini-SAS cables to the P840 controller.

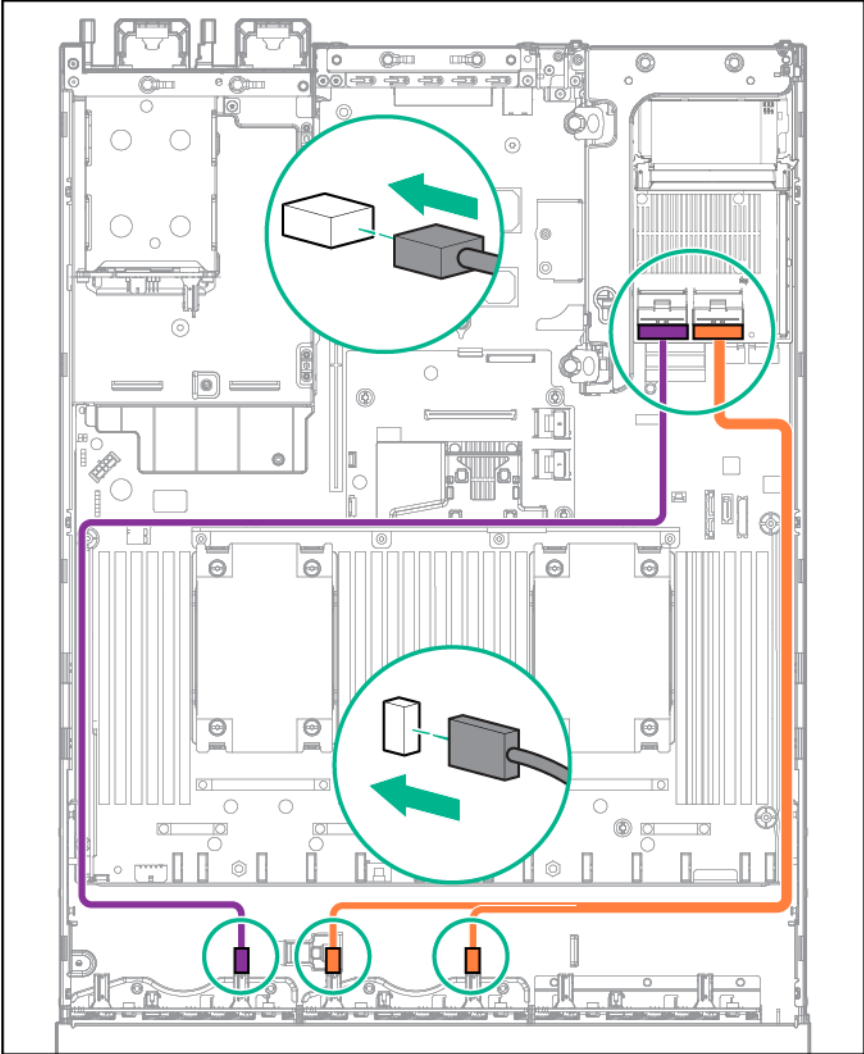

- 12LFF drives are installed in the front, and 3LFF drives are installed at the rear of the server — Connect the 12LFF Mini-SAS cable and the 3LFF Mini-SAS Y cable to the P840 controller.

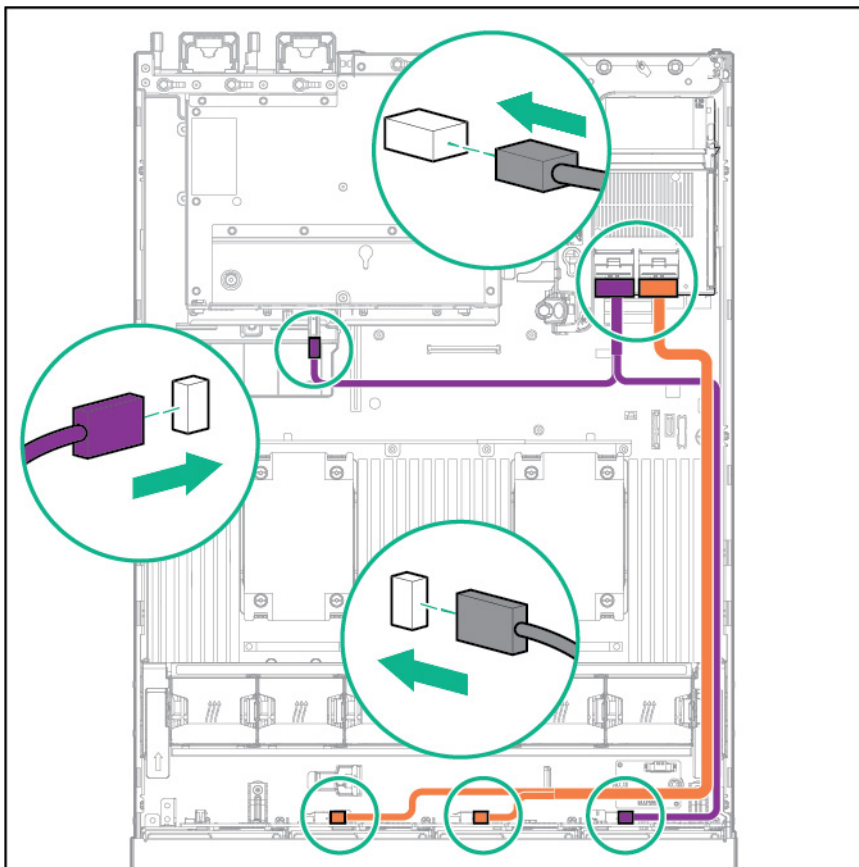

## HPE Smart Array P440ar Controller cabling

- Connect the Mini-SAS cable to the P440ar controller for the following configurations:
  - 24SFF drive configuration
  - 16SFF drives with front 2SFF drives and VGA/USB configuration
  - 6NVMe, 8SFF, and front 2SFF drives with VGA/USB configuration

The image below shows the 24SFF configuration. The image might vary from your server depending on the configuration installed. However, the cabling for the P440ar controller remains the same.

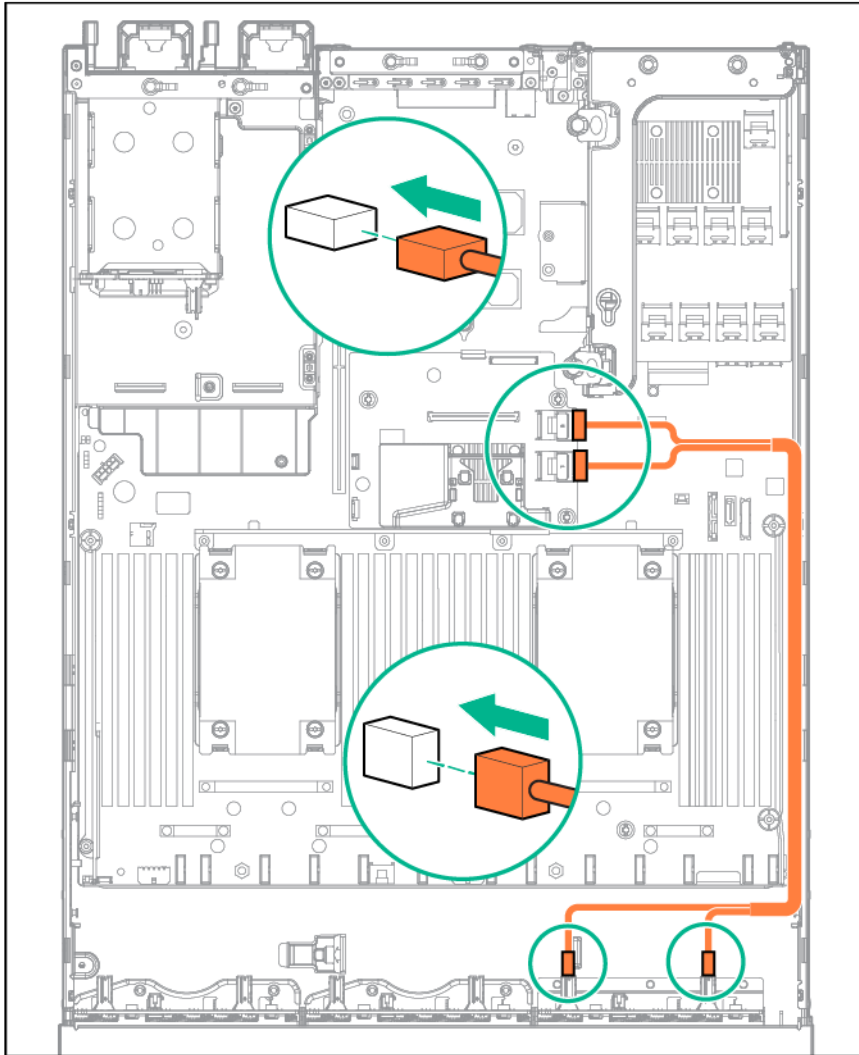

- 24SFF drives at the front and 2SFF drives at the rear of the server — Connect the P440ar controller cables to the 12G SAS Expander port 1 and port 2.

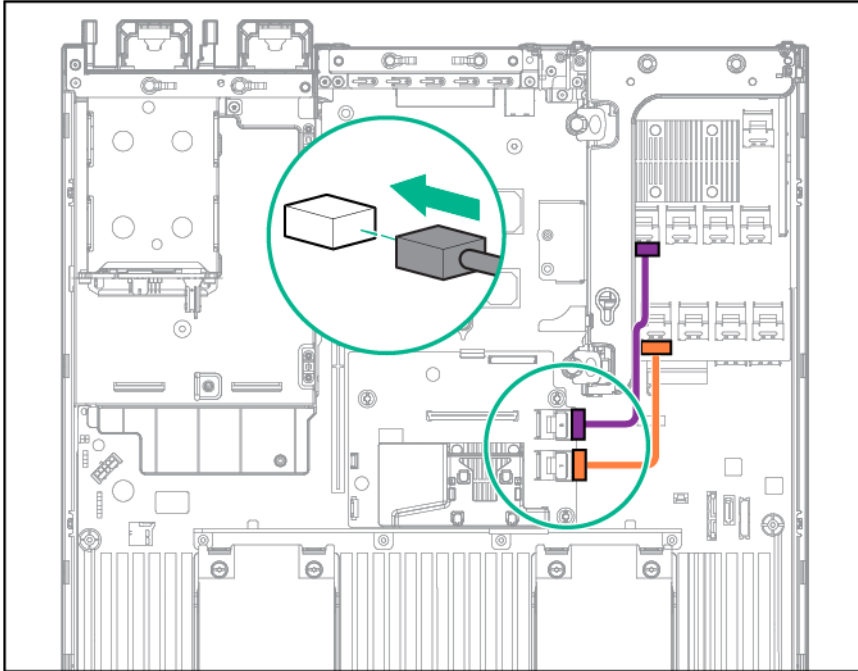

- 4LFF drive configuration — Connect the 4LFF Mini-SAS cable to the P440ar controller.

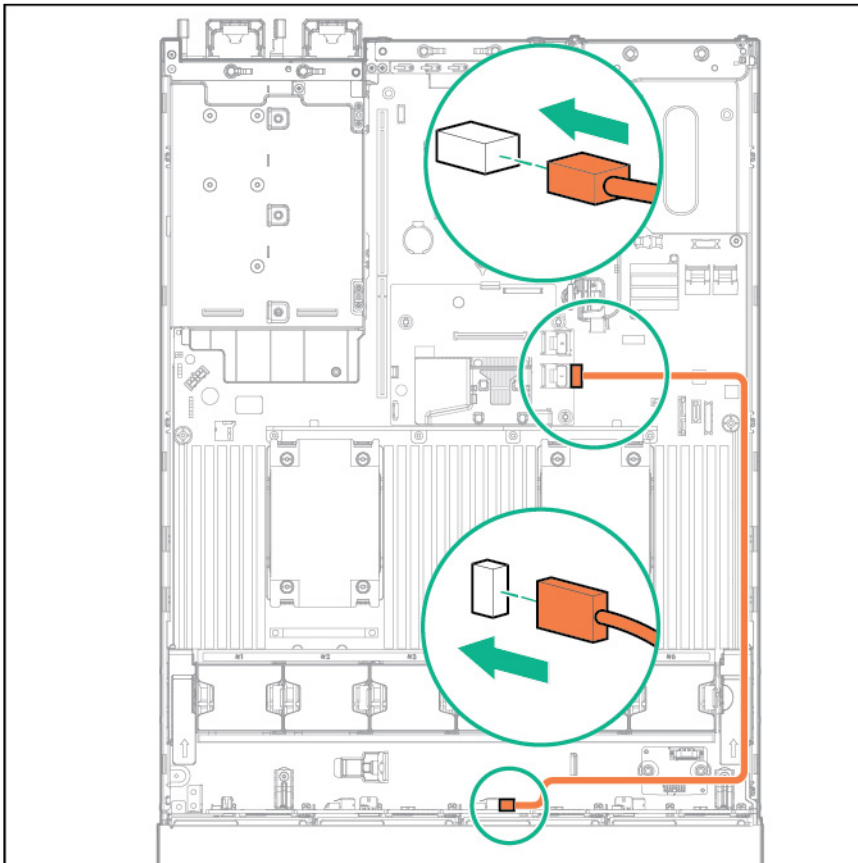

- 12LFF drives at the front, and 3LFF drives at the rear of the server without the 12G SAS Expander — Connect one 12LFF Mini-SAS cable to the P440ar controller.

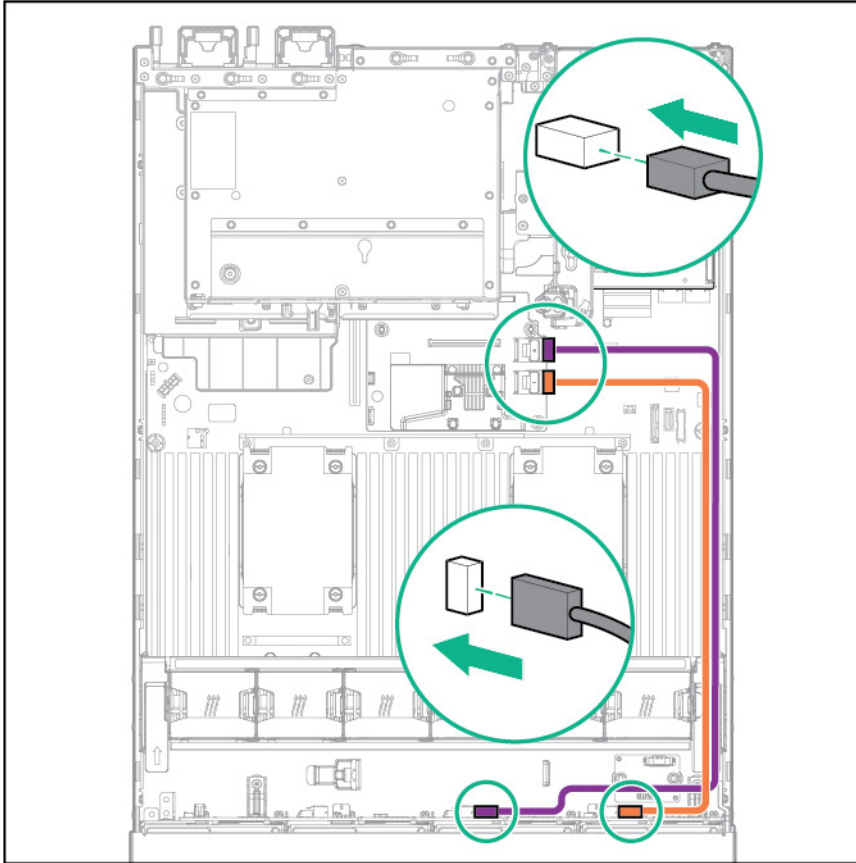

- 12LFF drives at the front, and 3LFF drives at the rear of the server with 12G SAS Expander — Connect the P440ar controller cables to port 1 and port 2 on the 12G SAS Expander.

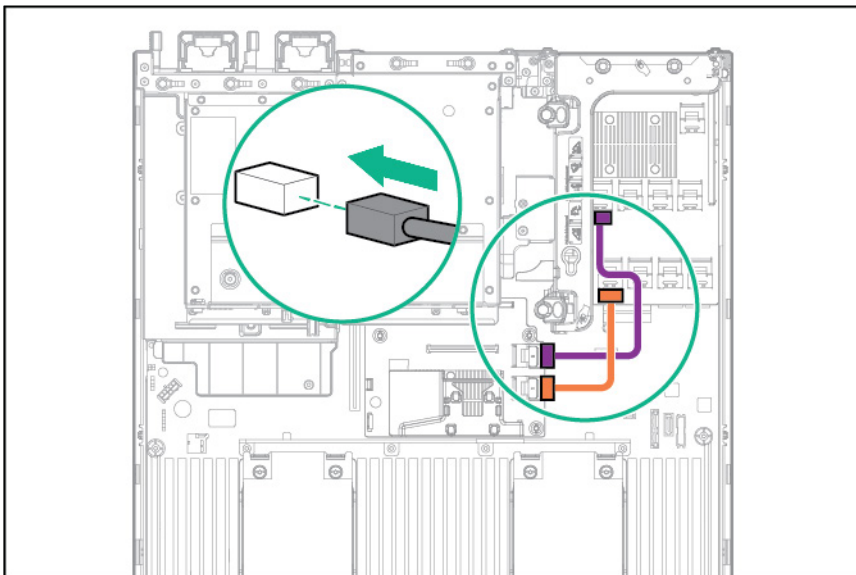

# HPE Smart Array P840ar Controller cabling

- 16SFF drive configuration — Connect the two Mini-SAS cables to the P840ar controller.

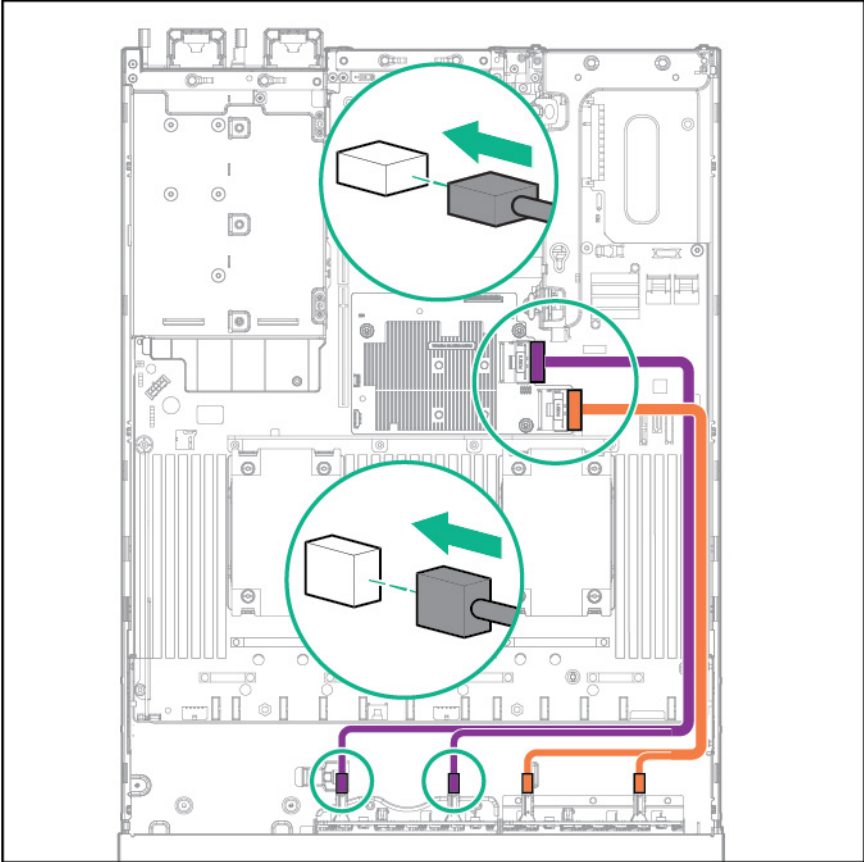

- 16SFF and 6NVMe drives with Express Bay Enablement option installed — Connect the two 8SFF Mini-SAS cables to the P840ar controller.

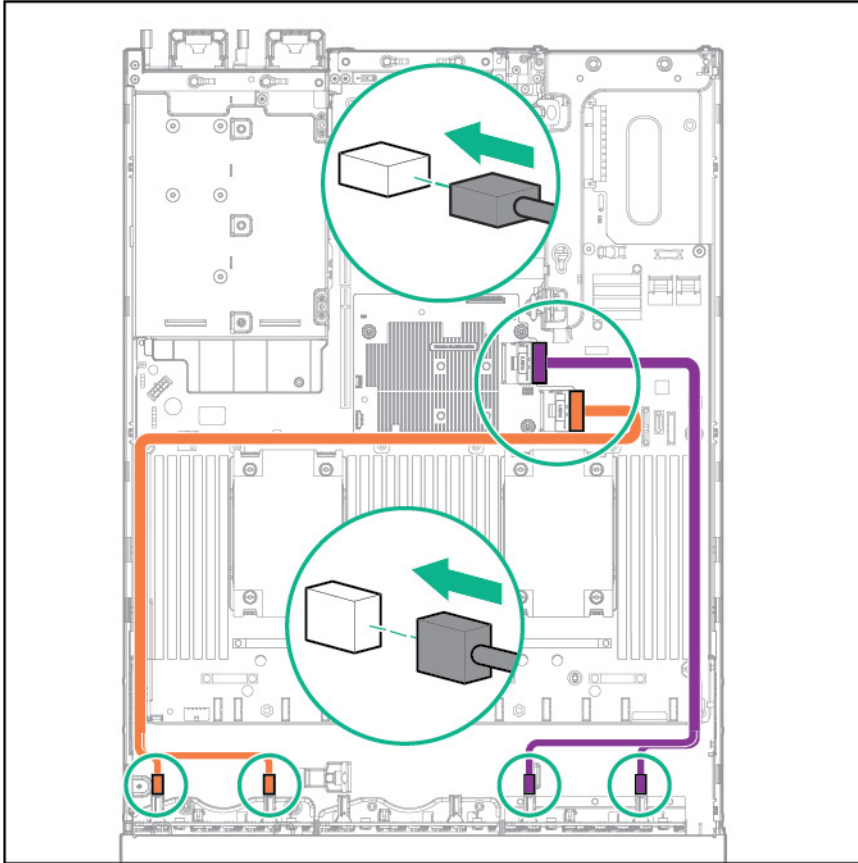

- 24SFF drives at the front, and 2SFF drives at the rear of the server — Connect the P840ar controller Mini-SAS Y cable to the SAS expander.

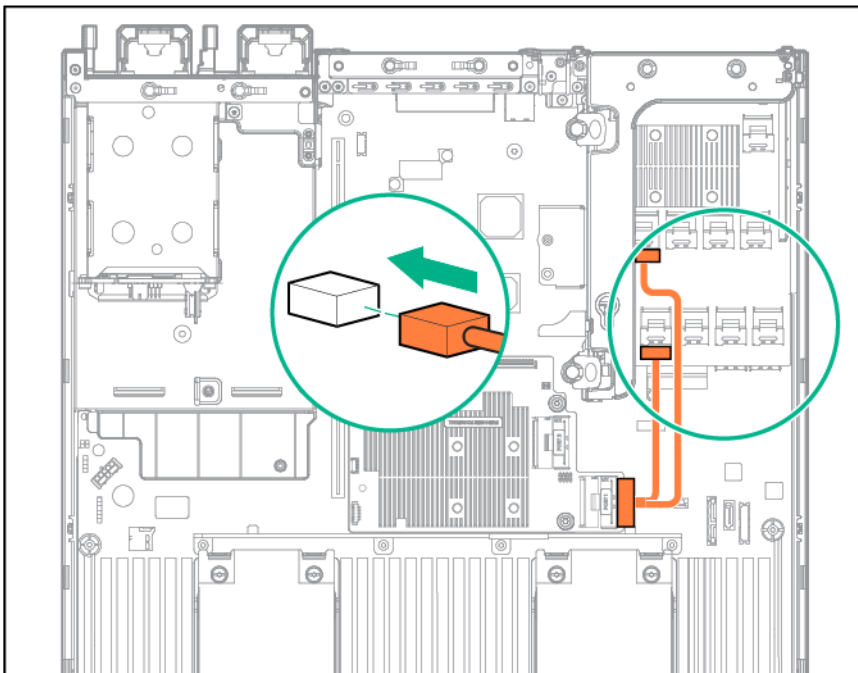



- 12LFF drives at the front, and 2SFF drives at the rear of the server — Connect the 12LFF Mini-SAS cable and the 2SFF Mini-SAS Y cable to the P840ar Controller.

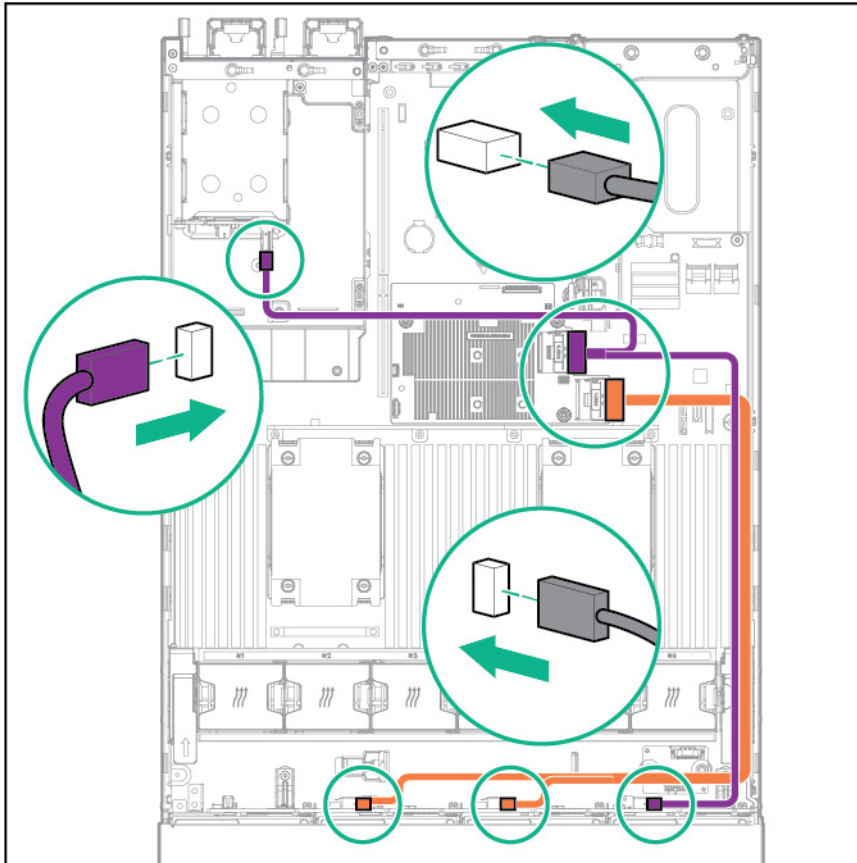

- 12LFF configuration — Connect the two 12LFF Mini-SAS cables to the P840ar controller.

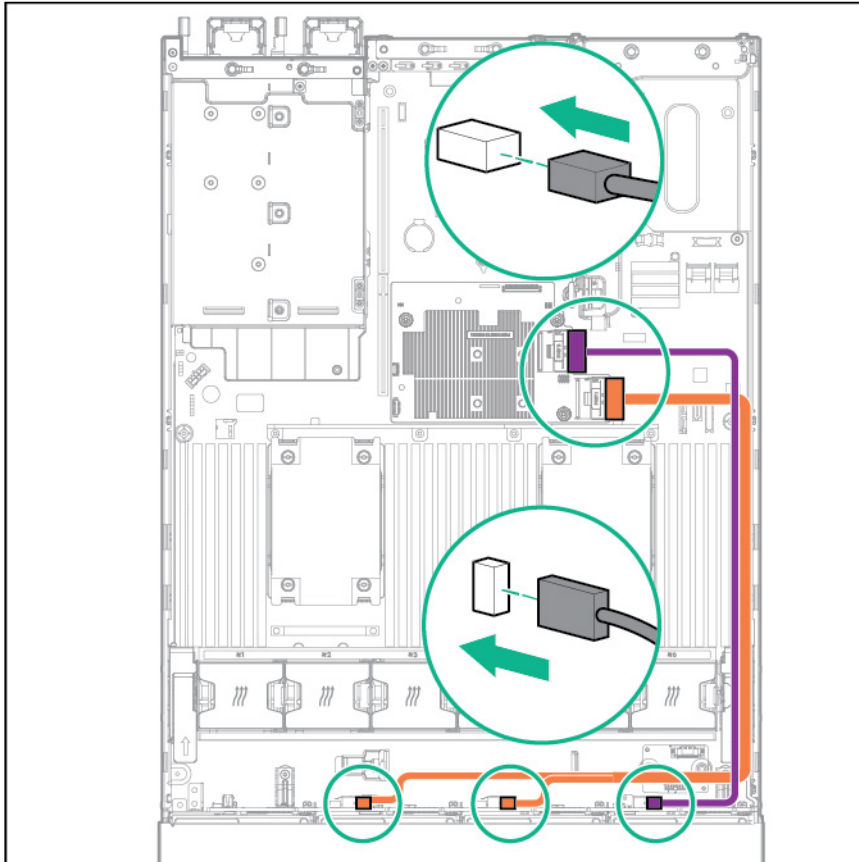

- 12LFF drives at the front, and 3LFF drives at the rear of the server — Connect the 12LFF Mini-SAS cable and the 3LFF Mini-SAS Y cable to the P840ar controller.

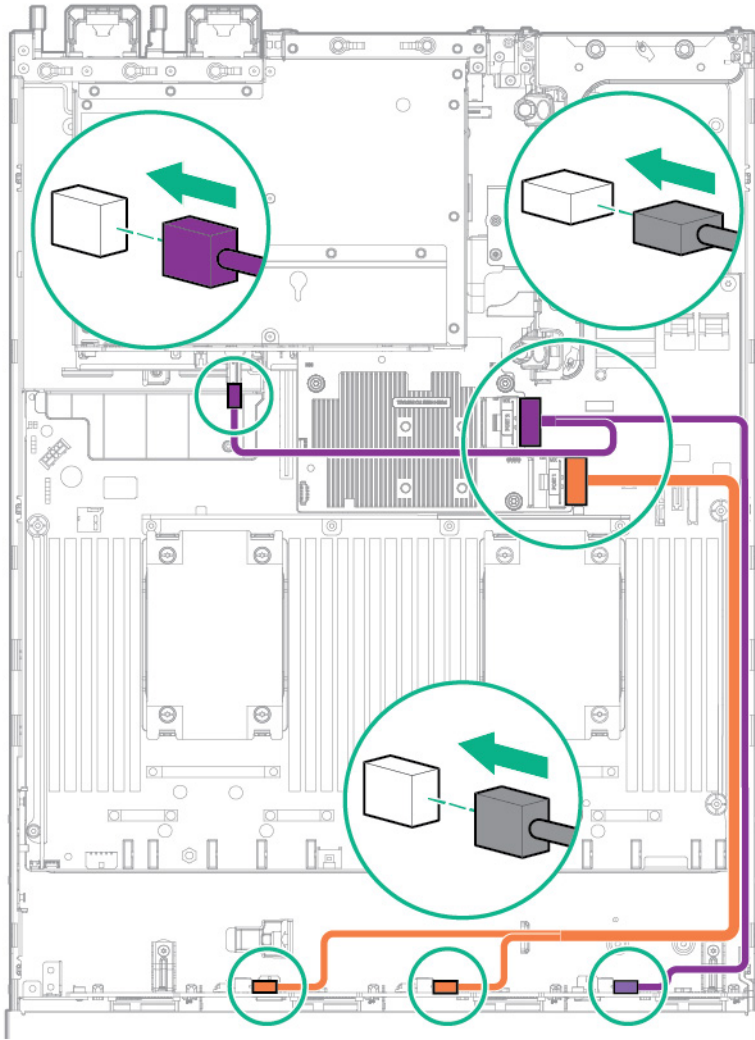

# Universal media bay cabling

Connect the VGA cable to the optional VGA connector. Connect the USB cable to the front dual internal USB 3.0 connector.

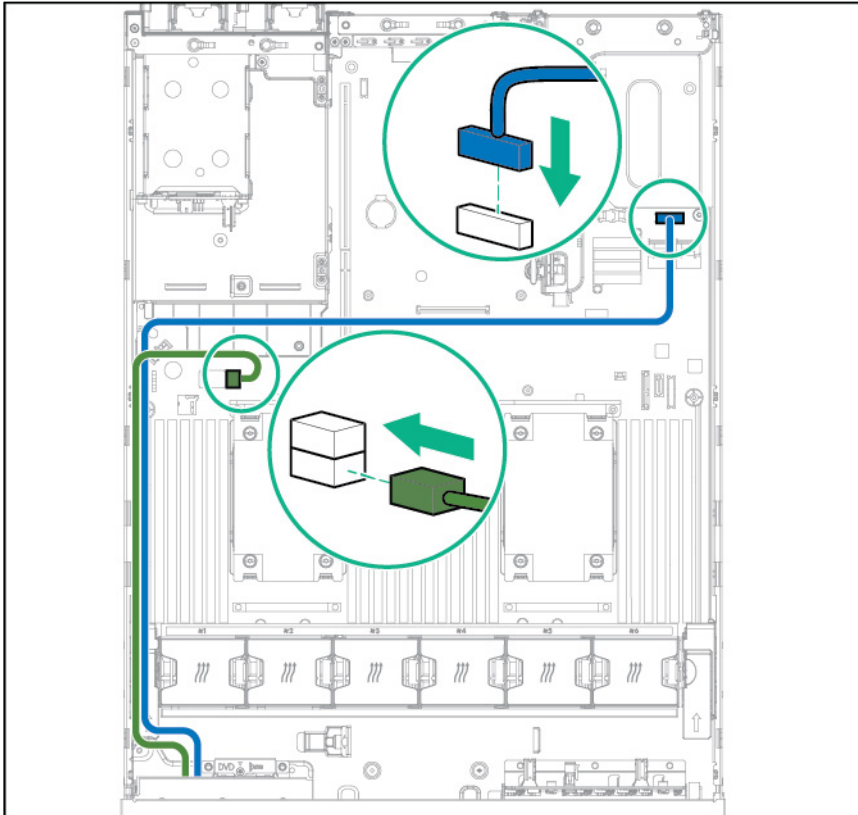

Connect the SATA optical drive cable to the front optical disk drive connector.

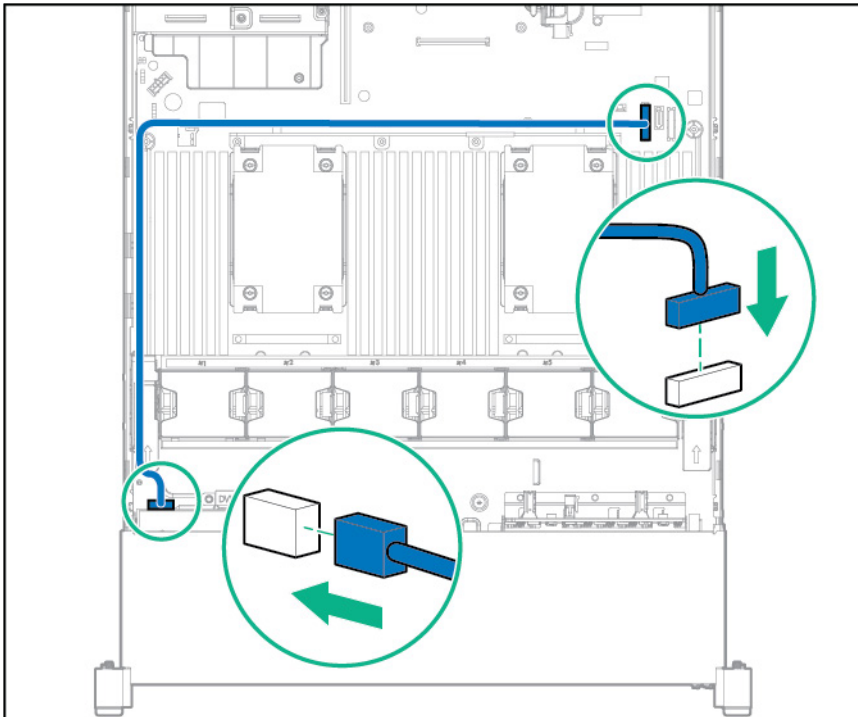

Connect the 2 SFF drive bay data cable to one of the following connections, depending on the configuration:

- PCI expansion board

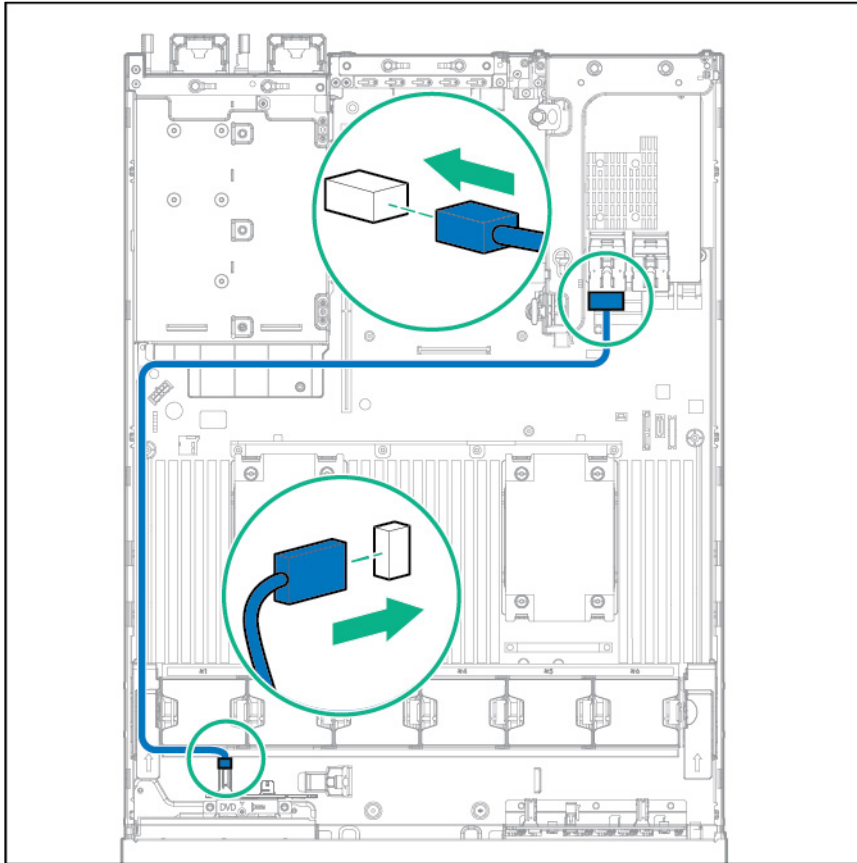

- x4 SATA connector

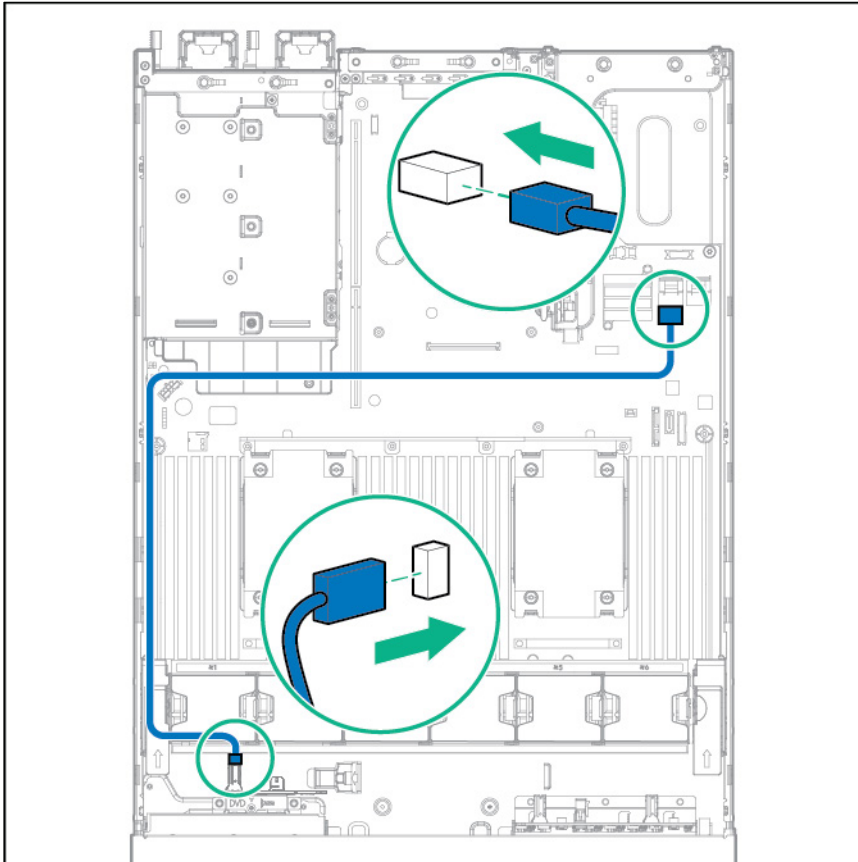

Connect the 2 SFF drive bay power cable.

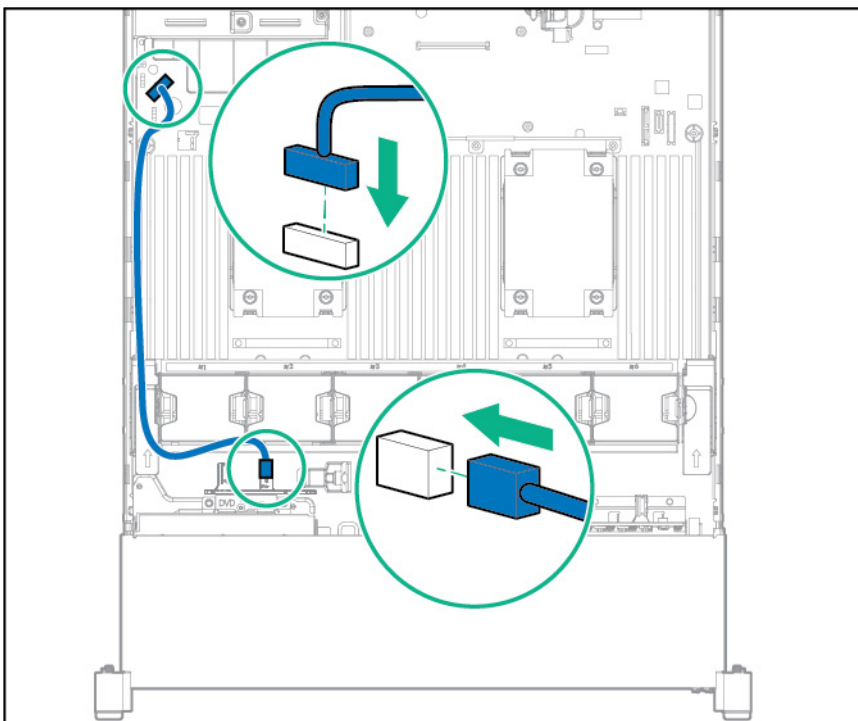

# 150W PCIe power cable option

**CAUTION:** To prevent damage to the server or expansion boards, power down the server and remove all AC power cords before removing or installing the PCI expansion cage.

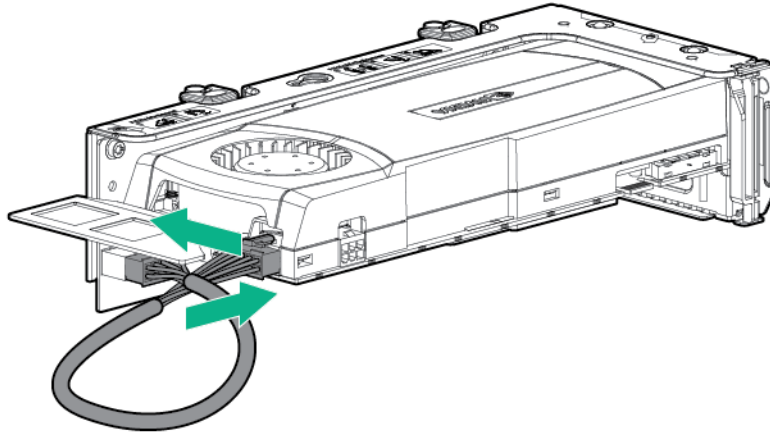

## M.2 SSD Enablement Board option cabling

The M.2 SSD Enablement Board option is supported in both the primary and secondary PCI riser cage. Cable the option according to the location in the server:

- **Primary PCI riser cage**

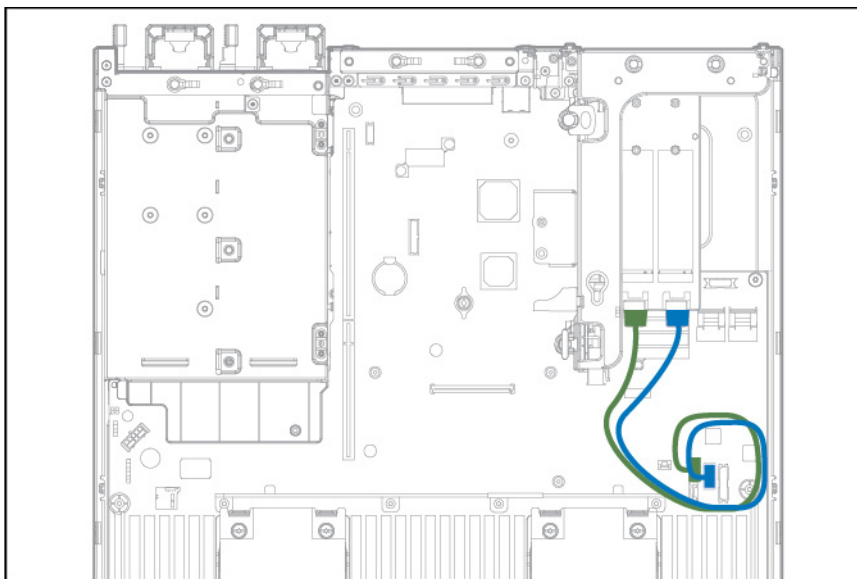

- **Secondary PCI riser cage**

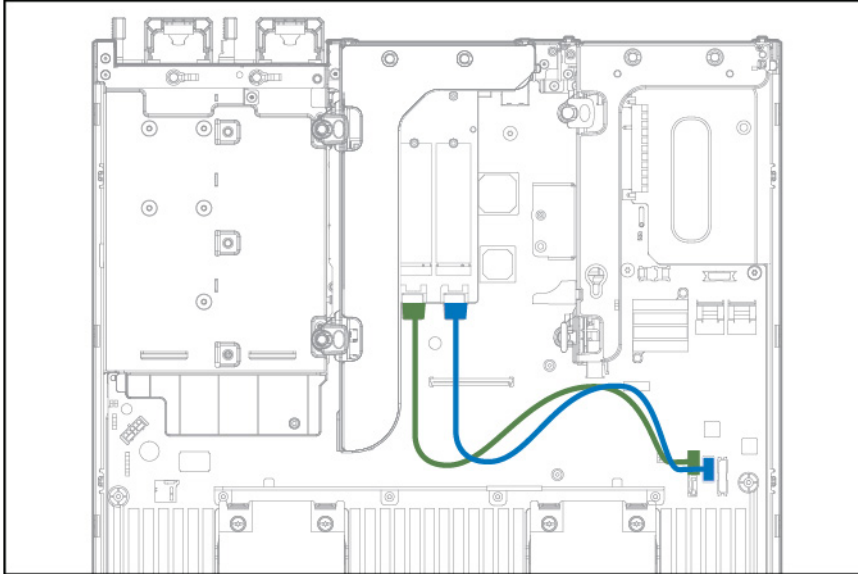



# Software and configuration utilities

## Server mode

The software and configuration utilities presented in this section operate in online mode, offline mode, or in both modes. Depending on the server model, your server may not support all of the tools and solutions in this section.

All software and configuration utilities listed in this table are not supported on all HP ProLiant Gen8 servers.

Software or configuration utility	Server mode
HP iLO ("HPE iLO" on page 169)	Online and Offline
Active Health System (on page 170)	Online and Offline
Integrated Management Log (on page 171)	Online and Offline
Intelligent Provisioning (on page 172)	Offline
HP Insight Diagnostics ("HPE Insight Diagnostics" on page 172)	Online and Offline
HP Insight Remote Support software ("HPE Insight Remote Support" on page 171)	Online
HP Insight Online ("Insight Online" on page 172)	Online
Erase Utility (on page 173)	Offline
Scripting Toolkit for Windows and Linux (on page 173)	Online
HP Service Pack for ProLiant ("Service Pack for ProLiant" on page 173)	Online and Offline
HP Smart Update Manager (on page 174)	Online and Offline
UEFI System Utilities ("HPE UEFI System Utilities" on page 174) — HP ProLiant DL580 Gen8 Server only	Offline
HP ROM-Based Setup Utility	Offline
Array Configuration Utility	Online and Offline
HP Smart Storage Administrator ("HPE Smart Storage Administrator" on page 177)	Online and Offline
Option ROM Configuration for Arrays	Offline
ROMPaq utility	Offline

## Product QuickSpecs

For more information about product features, specifications, options, configurations, and compatibility, see the product QuickSpecs on the Hewlett Packard Enterprise website (<http://www.hpe.com/info/qs>).

## HPE iLO

iLO is a remote server management processor embedded on the system boards of HPE ProLiant and Synergy servers. iLO enables the monitoring and controlling of servers from remote locations. HPE iLO management is a powerful tool that provides multiple ways to configure, update, monitor, and repair servers remotely. iLO (Standard) comes preconfigured on HPE servers **without an additional cost or license**.

Features that enhance server administrator productivity are licensed. For more information, see the iLO documentation on the Hewlett Packard Enterprise website (<http://www.hpe.com/info/ilo-docs>).

# Active Health System

The HPE Active Health System provides the following features:

- Combined diagnostics tools/scanners
- Always on, continuous monitoring for increased stability and shorter downtimes
- Rich configuration history
- Health and service alerts
- Easy export and upload to Service and Support

The Active Health System monitors and records changes in the server hardware and system configuration. The Active Health System assists in diagnosing problems and delivering rapid resolution if server failures occur.

The Active Health System collects the following types of data:

- Server model
- Serial number
- Processor model and speed
- Storage capacity and speed
- Memory capacity and speed
- Firmware/BIOS

Active Health System does not collect information about Active Health System users' operations, finances, customers, employees, partners, or data center, such as IP addresses, host names, user names, and passwords. Active Health System does not parse or change operating system data from third-party error event log activities, such as content created or passed through by the operating system.

The data that is collected is managed according to the Hewlett Packard Enterprise Data Privacy policy. For more information see the Hewlett Packard Enterprise website (<http://www.hpe.com/info/privacy>).

The Active Health System, in conjunction with the system monitoring provided by Agentless Management or SNMP Pass-thru, provides continuous monitoring of hardware and configuration changes, system status, and service alerts for various server components.

The Agentless Management Service is available in the SPP, which can be downloaded from the Hewlett Packard Enterprise website (<http://www.hpe.com/servers/spp/download>). The Active Health System log can be downloaded manually from iLO 4 or HPE Intelligent Provisioning and sent to Hewlett Packard Enterprise.

For more information, see the following documents:

- *iLO User Guide* on the Hewlett Packard Enterprise website (<http://www.hpe.com/info/ilo/docs>)
- *Intelligent Provisioning User Guide* on the Hewlett Packard Enterprise website (<http://www.hpe.com/info/intelligentprovisioning/docs>)

## iLO RESTful API support

HPE iLO 4 firmware version 2.00 and later includes the iLO RESTful API. The iLO RESTful API is a management interface that server management tools can use to perform configuration, inventory, and monitoring of the ProLiant server via iLO. The iLO RESTful API uses basic HTTPS operations (GET, PUT, POST, DELETE, and PATCH) to submit or return JSON-formatted data with iLO web server.

HPE iLO 4 2.30 and later is Redfish 1.0-conformant while remaining backward compatible with the existing iLO RESTful API.

HPE iLO 4 supports the iLO RESTful API with ProLiant Gen8 and later servers. For more information about the iLO RESTful API, see the Hewlett Packard Enterprise website (<http://www.hpe.com/info/restfulinterface/docs>).

## Integrated Management Log

The IML records hundreds of events and stores them in an easy-to-view form. The IML timestamps each event with 1-minute granularity.

You can view recorded events in the IML in several ways, including the following:

- From within HPE SIM
- From within UEFI System Utilities ("[HPE UEFI System Utilities](#)" on page [174](#))
- From within the Embedded UEFI shell (on page [176](#))
- From within operating system-specific IML viewers:
  - For Windows: IML Viewer
  - For Linux: IML Viewer Application
- From within the iLO web interface
- From within Insight Diagnostics ("[HPE Insight Diagnostics](#)" on page [172](#))

## HPE Insight Remote Support

Hewlett Packard Enterprise strongly recommends that you register your device for remote support to enable enhanced delivery of your Hewlett Packard Enterprise warranty, HPE support services, or Hewlett Packard Enterprise contractual support agreement. Insight Remote Support supplements your monitoring continuously to ensure maximum system availability by providing intelligent event diagnosis, and automatic, secure submission of hardware event notifications to Hewlett Packard Enterprise, which will initiate a fast and accurate resolution, based on your product's service level. Notifications can be sent to your authorized Hewlett Packard Enterprise Channel Partner for onsite service, if configured and available in your country.

For more information, see *Insight Remote Support and Insight Online Setup Guide for ProLiant Servers and BladeSystem c-Class Enclosures* on the Hewlett Packard Enterprise website (<http://www.hpe.com/info/insightremotesupport/docs>). Insight Remote Support is available as part of Hewlett Packard Enterprise Warranty, HPE support services, or Hewlett Packard Enterprise contractual support agreement.

## HPE Insight Remote Support central connect

When you use the embedded Remote Support functionality with ProLiant Gen8 and later server models and BladeSystem c-Class enclosures, you can register a server or enclosure to communicate to Hewlett Packard Enterprise through an Insight Remote Support centralized Hosting Device in your local environment. All configuration and service event information is routed through the Hosting Device. This information can be viewed by using the local Insight Remote Support user interface or the web-based view in Insight Online.

For more information, see *Insight Remote Support Release Notes* on the Hewlett Packard Enterprise website (<http://www.hpe.com/info/insightremotesupport/docs>).

## HPE Insight Online direct connect

When you use the embedded Remote Support functionality with ProLiant Gen8 and later server models and BladeSystem c-Class enclosures, you can register a server or enclosure to communicate directly to Insight Online without the need to set up an Insight Remote Support centralized Hosting Device in your local environment. Insight Online will be your primary interface for remote support information.

For more information, see the product documentation on the Hewlett Packard Enterprise website (<http://www.hpe.com/info/insightremotesupport/docs>).

## Insight Online

HPE Insight Online is a capability of the Support Center portal. Combined with Insight Remote Support central connect or Insight Online direct connect, it automatically aggregates device health, asset, and support information with contract and warranty information, and then secures it in a single, personalized dashboard that is viewable from anywhere at any time. The dashboard organizes your IT and service data to help you understand and respond to that information more quickly. With specific authorization from you, an authorized Channel Partner can also view your IT environment remotely using Insight Online.

For more information about using Insight Online, see *Insight Online User's Guide* on the Hewlett Packard Enterprise website (<http://www.hpe.com/info/enterprise/docs>).

## Intelligent Provisioning

Intelligent Provisioning is a single-server deployment tool embedded in ProLiant Gen8 and later servers that simplifies ProLiant server setup, providing a reliable and consistent way to deploy ProLiant server configurations:

- Intelligent Provisioning assists with the OS installation process by preparing the system for installing "off-the-shelf" and Hewlett Packard Enterprise branded versions of operating system software and integrating optimized ProLiant server support software.
- Intelligent Provisioning provides maintenance-related tasks using the Perform Maintenance window.
- Intelligent Provisioning provides installation help for Microsoft Windows, Red Hat and SUSE Linux, and VMware operating systems. For specific OS support, see the *Intelligent Provisioning Release Notes* on the Hewlett Packard Enterprise website (<http://www.hpe.com/info/intelligentprovisioning/docs>).

For more information about Intelligent Provisioning software, see the Hewlett Packard Enterprise website (<http://www.hpe.com/servers/intelligentprovisioning>). For Intelligent Provisioning recovery media downloads, see the Resources tab on the Hewlett Packard Enterprise website (<http://www.hpe.com/servers/intelligentprovisioning>). For consolidated drive and firmware update packages, see the Smart Update: Server Firmware and Driver Updates page on the Hewlett Packard Enterprise website (<http://www.hpe.com/info/SmartUpdate>).

## HPE Insight Diagnostics

The Insight Diagnostics is a proactive server management tool, available in both offline and online versions, that provides diagnostics and troubleshooting capabilities to assist IT administrators who verify server installations, troubleshoot problems, and perform repair validation.

The Insight Diagnostics Offline Edition performs various in-depth system and component testing while the OS is not running. To run this utility, boot the server using Intelligent Provisioning (on page 172).

The Insight Diagnostics Online Edition is a web-based application that captures system configuration and other related data needed for effective server management. Available in Microsoft Windows and Linux versions, the utility helps to ensure proper system operation.

For more information or to download the utility, see the Hewlett Packard Enterprise website (<http://www.hpe.com/info/InsightDiagnostics>). The Insight Diagnostics Online Edition is also available in the SPP ("[Service Pack for ProLiant](#)" on page 173).

## HPE Insight Diagnostics survey functionality

HPE Insight Diagnostics (on page 172) provides survey functionality that gathers critical hardware and software information on ProLiant servers.

This functionality supports operating systems that are supported by the server. For operating systems supported by the server, see the Hewlett Packard Enterprise website (<http://www.hpe.com/info/supportos>).

If a significant change occurs between data-gathering intervals, the survey function marks the previous information and overwrites the survey data files to reflect the latest changes in the configuration.

Survey functionality is installed with every Intelligent Provisioning-assisted Insight Diagnostics installation, or it can be installed through the SPP ("[Service Pack for ProLiant](#)" on page 173).

## Erase Utility

---

**△ CAUTION:** Perform a backup before running the Erase Utility. The utility sets the system to its original factory state, deletes the current hardware configuration information, including array setup and disk partitioning, and erases all connected hard drives completely. Before using this utility, see the instructions in the *Intelligent Provisioning User Guide*.

---

Use the Erase Utility to erase drives and Active Health System logs, and to reset UEFI System Utilities settings. Run the Erase Utility if you must erase the system for the following reasons:

- You want to install a new operating system on a server with an existing operating system.
- You encounter an error when completing the steps of a factory-installed operating system installation.

To access the Erase Utility, click the Perform Maintenance icon from the Intelligent Provisioning home screen, and then select **Erase**.

For more information about the Erase Utility, see the *Intelligent Provisioning User Guide* on the Hewlett Packard Enterprise website (<http://www.hpe.com/info/intelligentprovisioning/docs>).

## Scripting Toolkit for Windows and Linux

The STK for Windows and Linux is a server deployment product that delivers an unattended automated installation for high-volume server deployments. The STK is designed to support ProLiant servers. The toolkit includes a modular set of utilities and important documentation that describes how to apply these tools to build an automated server deployment process.

The STK provides a flexible way to create standard server configuration scripts. These scripts are used to automate many of the manual steps in the server configuration process. This automated server configuration process cuts time from each deployment, making it possible to scale rapid, high-volume server deployments.

For more information or to download the STK, see the Hewlett Packard Enterprise website (<http://www.hpe.com/servers/proliant/stk>).

## Service Pack for ProLiant

The SPP is a comprehensive systems software (drivers and firmware) solution delivered as a single package with major server releases. This solution uses HP SUM as the deployment tool and is tested on all supported ProLiant servers including ProLiant Gen8 and later servers.

SPP can be used in an online mode on a Windows or Linux hosted operating system, or in an offline mode where the server is booted to an operating system included on the ISO file so that the server can be updated automatically with no user interaction or updated in interactive mode.

For more information or to download SPP, see one of the following pages on the Hewlett Packard Enterprise website:

- Service Pack for ProLiant download page (<http://www.hpe.com/servers/spp/download>)

- Smart Update: Server Firmware and Driver Updates page (<http://www.hpe.com/info/SmartUpdate>)

## HP Smart Update Manager

HP SUM is a product used to install and update firmware, drivers, and systems software on ProLiant servers. The HP SUM provides a GUI and a command-line scriptable interface for deployment of systems software for single or one-to-many ProLiant servers and network-based targets, such as iLOs, OAs, and VC Ethernet and Fibre Channel modules.

For more information about HP SUM, see the product page on the Hewlett Packard Enterprise website (<http://www.hpe.com/servers/hpsum>).

To download HP SUM, see the Hewlett Packard Enterprise website (<http://www.hpe.com/servers/hpsum/download>).

To access the *HP Smart Update Manager User Guide*, see the HP SUM Information Library (<http://www.hpe.com/info/hpsum/documentation>).

## HPE UEFI System Utilities

The UEFI System Utilities is embedded in the system ROM. The UEFI System Utilities enable you to perform a wide range of configuration activities, including:

- Configuring system devices and installed options
- Enabling and disabling system features
- Displaying system information
- Selecting the primary boot controller
- Configuring memory options
- Selecting a language
- Launching other pre-boot environments such as the Embedded UEFI Shell and Intelligent Provisioning

For more information on the UEFI System Utilities, see the *HPE UEFI System Utilities User Guide for HPE ProLiant Gen9 Servers* on the Hewlett Packard Enterprise website (<http://www.hpe.com/info/uefi/docs>).

Scan the QR code located at the bottom of the screen to access mobile-ready online help for the UEFI System Utilities and UEFI Shell. For on-screen help, press **F1**.

## Using UEFI System Utilities

To use the UEFI System Utilities, use the following keys.

Action	Key
Access System Utilities	F9 during server POST
Navigate menus	Up and Down arrows
Select items	Enter
Save selections	F10
Access Help for a highlighted configuration option*	F1

\*Scan the QR code on the screen to access online help for the UEFI System Utilities and UEFI Shell.

Default configuration settings are applied to the server at one of the following times:

- Upon the first system power-up
- After defaults have been restored

Default configuration settings are sufficient for typical server operations; however, you can modify configuration settings as needed. The system prompts you for access to the UEFI System Utilities each time the system is powered up.

## Flexible boot control

This feature enables you to do the following:

- Add Boot Options
  - Browse all FAT16 and FAT32 file systems.
  - Select an X64 UEFI application with an .EFI extension to add as a new UEFI boot option, such as an OS boot loader or other UEFI application.  
The new boot option is appended to the boot order list. When you select a file, you are prompted to enter the boot option description (which is then displayed in the Boot menu), as well as any optional data to be passed to an .EFI application.
- Boot to System Utilities  
After pre-POST, the boot options screen appears. During this time, you can access the UEFI System Utilities by pressing the **F9** key.
- Choose between supported modes: Legacy BIOS Boot Mode or UEFI Boot Mode



**IMPORTANT:** If the default boot mode settings are different than the user defined settings, the system may not boot the OS installation if the defaults are restored. To avoid this issue, use the User Defined Defaults feature in UEFI System Utilities to override the factory default settings.

For more information, see the *HPE UEFI System Utilities User Guide for HPE ProLiant Gen9 Servers* on the Hewlett Packard Enterprise website (<http://www.hpe.com/info/uefi/docs>).

## Restoring and customizing configuration settings

You can reset all configuration settings to the factory default settings, or you can restore system default configuration settings, which are used instead of the factory default settings.

You can also configure default settings as necessary, and then save the configuration as the custom default configuration. When the system loads the default settings, it uses the custom default settings instead of the factory defaults.

## Secure Boot configuration

Secure Boot is integrated in the UEFI specification on which the Hewlett Packard Enterprise implementation of UEFI is based. Secure Boot is completely implemented in the BIOS and does not require special hardware. It ensures that each component launched during the boot process is digitally signed and that the signature is validated against a set of trusted certificates embedded in the UEFI BIOS. Secure Boot validates the software identity of the following components in the boot process:

- UEFI drivers loaded from PCIe cards
- UEFI drivers loaded from mass storage devices
- Pre-boot UEFI shell applications
- OS UEFI boot loaders

Once enabled, only firmware components and operating systems with boot loaders that have an appropriate digital signature can execute during the boot process. Only operating systems that support Secure Boot and have an EFI boot loader signed with one of the authorized keys can boot when Secure Boot is enabled. For more information about supported operating systems, see the *HPE UEFI System Utilities and Shell Release Notes for HPE ProLiant Gen9 Servers* on the Hewlett Packard Enterprise website (<http://www.hpe.com/info/uefi/docs>).

A physically present user can customize the certificates embedded in the UEFI BIOS by adding/removing their own certificates.

When Secure Boot is enabled, the System Maintenance Switch does not restore all manufacturing defaults when set to the ON position. For security reasons, the following are not restored to defaults when the System Maintenance Switch is in the ON position:

- Secure Boot is not disabled and remains enabled.
- The Boot Mode remains in UEFI Boot Mode even if the default boot mode is Legacy Boot Mode.
- The Secure Boot Database is not restored to its default state.
- iSCSI Software Initiator configuration settings are not restored to defaults.

## Embedded UEFI shell

The system BIOS in all ProLiant Gen9 servers includes an Embedded UEFI Shell in the ROM. The UEFI Shell environment provides an API, a command line prompt, and a set of CLIs that allow scripting, file manipulation, and system information. These features enhance the capabilities of the UEFI System Utilities.

For more information, see the following documents:

- *HPE UEFI Shell User Guide for HPE ProLiant Gen9 Servers* on the Hewlett Packard Enterprise website (<http://www.hpe.com/info/uefi/docs>)
- *UEFI Shell Specification* on the UEFI website (<http://www.uefi.org/specifications>)

## Embedded Diagnostics option

The system BIOS in all ProLiant Gen9 servers includes an Embedded Diagnostics option in the ROM. The Embedded Diagnostics option can run comprehensive diagnostics of the server hardware, including processors, memory, drives, and other server components.

For more information on the Embedded Diagnostics option, see the *HPE UEFI System Utilities User Guide for HPE ProLiant Gen9 Servers* on the Hewlett Packard Enterprise website (<http://www.hpe.com/info/uefi/docs>).

## iLO RESTful API support for UEFI

The ProLiant Gen9 servers include support for a UEFI compliant System BIOS, along with UEFI System Utilities and Embedded UEFI Shell pre-boot environments. ProLiant Gen9 servers also support configuring the UEFI BIOS settings using the iLO RESTful API, a management interface that server management tools can use to perform configuration, inventory, and monitoring of a ProLiant server. The iLO RESTful API uses basic HTTPS operations (GET, PUT, POST, DELETE, and PATCH) to submit or return JSON-formatted data with iLO web server.

For more information about the iLO RESTful API and the RESTful Interface Tool, see the Hewlett Packard Enterprise website (<http://www.hpe.com/info/restfulinterface/docs>).

## Re-entering the server serial number and product ID

After you replace the system board, you must re-enter the server serial number and the product ID.



1. During the server startup sequence, press the **F9** key to access UEFI System Utilities.
2. Select the **System Configuration > BIOS/Platform Configuration (RBSU) > Advanced Options > Advanced System ROM Options > Serial Number**, and then press the **Enter** key.
3. Enter the serial number and press the **Enter** key. The following message appears:  
The serial number should only be modified by qualified service personnel. This value should always match the serial number located on the chassis.
4. Press the **Enter** key to clear the warning.
5. Enter the serial number and press the **Enter** key.
6. Select **Product ID**. The following warning appears:  
Warning: The Product ID should ONLY be modified by qualified service personnel. This value should always match the Product ID located on the chassis.
7. Enter the product ID and press the **Enter** key.
8. Press the **F10** key to confirm exiting System Utilities. The server automatically reboots.

## Utilities and features

### HPE Smart Storage Administrator

The HPE SSA is a configuration and management tool for HPE Smart Array controllers. Starting with HPE ProLiant Gen8 servers, HPE SSA replaces ACU with an enhanced GUI and additional configuration features.

The HPE SSA exists in three interface formats: the HPE SSA GUI, the HPE SSA CLI, and HPE SSA Scripting. Although all formats provide support for configuration tasks, some of the advanced tasks are available in only one format.

Some HPE SSA features include the following:

- Supports online array capacity expansion, logical drive extension, assignment of online spares, and RAID or stripe size migration
- Provides diagnostic and SmartSSD Wear Gauge functionality on the Diagnostics tab
- For supported controllers, provides access to additional features.

For more information about HPE SSA, see the Hewlett Packard Enterprise website (<http://www.hpe.com/servers/ssa>).

### Automatic Server Recovery

ASR is a feature that causes the system to restart when a catastrophic operating system error occurs, such as a blue screen, ABEND, or panic. A system fail-safe timer, the ASR timer, starts when the System Management driver, also known as the Health Driver, is loaded. When the operating system is functioning properly, the system periodically resets the timer. However, when the operating system fails, the timer expires and restarts the server.

ASR increases server availability by restarting the server within a specified time after a system hang. You can disable ASR from the System Management Homepage or through UEFI System Utilities.

### USB support

Hewlett Packard Enterprise servers support both USB 2.0 ports and USB 3.0 ports. Both types of ports support installing all types of USB devices (USB 1.0, USB 2.0, and USB 3.0), but may run at lower speeds in specific situations:

- USB 3.0 capable devices operate at USB 2.0 speeds when installed in a USB 2.0 port.
- When the server is configured for UEFI Boot Mode, Hewlett Packard Enterprise provides legacy USB support in the pre-boot environment prior to the operating system loading for USB 1.0, USB 2.0, and USB 3.0 speeds.
- When the server is configured for Legacy BIOS Boot Mode, Hewlett Packard Enterprise provides legacy USB support in the pre-boot environment prior to the operating system loading for USB 1.0 and USB 2.0 speeds. While USB 3.0 ports can be used with all devices in Legacy BIOS Boot Mode, they are not available at USB 3.0 speeds in the pre-boot environment. Standard USB support (USB support from within the operating system) is provided by the OS through the appropriate USB device drivers. Support for USB 3.0 varies by operating system.

For maximum compatibility of USB 3.0 devices with all operating systems, Hewlett Packard Enterprise provides a configuration setting for USB 3.0 Mode. Auto is the default setting. This setting impacts USB 3.0 devices when connected to USB 3.0 ports in the following manner:

- **Auto (default)**—If configured in Auto Mode, USB 3.0 capable devices operate at USB 2.0 speeds in the pre-boot environment and during boot. When a USB 3.0 capable OS USB driver loads, USB 3.0 devices transition to USB 3.0 speeds. This mode provides compatibility with operating systems that do not support USB 3.0 while still allowing USB 3.0 devices to operate at USB 3.0 speeds with state-of-the-art operating systems.
- **Enabled**—If Enabled, USB 3.0 capable devices operate at USB 3.0 speeds at all times (including the pre-boot environment) when in UEFI Boot Mode. This mode should not be used with operating systems that do not support USB 3.0. If operating in Legacy Boot BIOS Mode, the USB 3.0 ports cannot function in the pre-boot environment and are not bootable.
- **Disabled**—If configured for Disabled, USB 3.0 capable devices function at USB 2.0 speeds at all times.

The pre-OS behavior of the USB ports is configurable in the UEFI System Utilities, so that the user can change the default operation of the USB ports. For more information, see the *HPE UEFI System Utilities User Guide for HPE ProLiant Gen9 Servers* on the Hewlett Packard Enterprise website (<http://www.hpe.com/info/uefi/docs>).

## External USB functionality

Hewlett Packard Enterprise provides external USB support to enable local connection of USB devices for server administration, configuration, and diagnostic procedures.

For additional security, external USB functionality can be disabled through USB options in UEFI System Utilities.

## Redundant ROM support

The server enables you to upgrade or configure the ROM safely with redundant ROM support. The server has a single ROM that acts as two separate ROM images. In the standard implementation, one side of the ROM contains the current ROM program version, while the other side of the ROM contains a backup version.

---

**NOTE:** The server ships with the same version programmed on each side of the ROM.

---

## Safety and security benefits

When you flash the system ROM, the flashing mechanism writes over the backup ROM and saves the current ROM as a backup, enabling you to switch easily to the alternate ROM version if the new ROM becomes corrupted for any reason. This feature protects the existing ROM version, even if you experience a power failure while flashing the ROM.

# Keeping the system current

## Access to Hewlett Packard Enterprise Support Materials

Access to some updates for ProLiant Servers may require product entitlement when accessed through the Hewlett Packard Enterprise Support Center support portal. Hewlett Packard Enterprise recommends that you have an HP Passport set up with relevant entitlements. For more information, see the Hewlett Packard Enterprise website (<http://www.hpe.com/support/AccessToSupportMaterials>).

## Updating firmware or System ROM

Multiple methods exist to update the firmware or System ROM:

- Service Pack for ProLiant (on page 173)
- FWUPDATE utility (on page 179)
- FWUpdate command from within the Embedded UEFI shell
- Firmware Update application in UEFI System Utilities ("[Firmware Update application in the UEFI System Utilities](#)" on page 180)
- Online Flash components (on page 180)

Product entitlement is required to perform updates. For more information, see "Accessing updates (on page 193)."

## FWUPDATE utility

The FWUPDATE utility enables you to upgrade the system firmware (BIOS).

To use the utility to upgrade the firmware:

1. Download the FWUPDATE flash component from the Hewlett Packard Enterprise Support Center website (<http://www.hpe.com/support/hpesc>).
2. Save the FWUPDATE flash components to a USB key.
3. Set the boot order so the USB key will boot first using one of the following options:
  - Configure the boot order so the USB key is the first bootable device.
  - Press **F11** (Boot Menu) when prompted during system boot to access the **One-Time Boot Menu**. This menu allows you to select the boot device for a specific boot and does not modify the boot order configuration settings.
4. Insert the USB key into an available USB port.
5. Boot the system.

The FWUPDATE utility checks the system and provides a choice (if more than one exists) of available firmware revisions.

To download the flash components, see the Hewlett Packard Enterprise Support Center website (<http://www.hpe.com/support/hpesc>).

For more information about the One-Time Boot Menu, see the *HPE UEFI System Utilities User Guide for HPE ProLiant Gen9 Servers* on the Hewlett Packard Enterprise website (<http://www.hpe.com/info/uefi/docs>).

## Firmware Update application in the UEFI System Utilities

For systems configured in either boot mode, update the firmware:

1. Access the System ROM Flash Binary component for your server from the Hewlett Packard Enterprise Support Center website (<http://www.hpe.com/support/hpesc>). When searching for the component, always select **OS Independent** to find the component.
2. Copy the binary file to a USB media or iLO virtual media.
3. Attach the media to the server.
4. During POST, press **F9** to enter System Utilities.
5. Select **Embedded Applications** → **Firmware Update** → **System ROM** → **Select Firmware File**.
6. Select the device containing the flash file.
7. Select the flash file. This step may take a few moments to complete.
8. Select **Start firmware update** and allow the process to complete.
9. Reboot the server. A reboot is required after the firmware update for the updates to take effect and for hardware stability to be maintained.

## Online Flash components

This component provides updated system firmware that can be installed directly on supported operating systems. Additionally, when used in conjunction with the HP SUM ("HP Smart Update Manager" on page 174), this Smart Component allows the user to update firmware on remote servers from a central location. This remote deployment capability eliminates the need for the user to be physically present at the server to perform a firmware update.

## Drivers



---

**IMPORTANT:** Always perform a backup before installing or updating device drivers.

---

The server includes new hardware that may not have driver support on all OS installation media.

If you are installing an Intelligent Provisioning-supported OS, use Intelligent Provisioning (on page 172) and its Configure and Install feature to install the OS and latest supported drivers.

If you do not use Intelligent Provisioning to install an OS, drivers for some of the new hardware are required. These drivers, as well as other option drivers, ROM images, and value-add software can be downloaded as part of an SPP.

If you are installing drivers from SPP, be sure that you are using the latest SPP version that your server supports. To verify that your server is using the latest supported version and for more information about SPP, see the Hewlett Packard Enterprise website (<http://www.hpe.com/servers/spp/download>).

To locate the drivers for a particular server, go to the Hewlett Packard Enterprise Support Center website (<http://www.hpe.com/support/hpesc>). Under **Select your HPE product**, enter the product name or number and click **Go**.

## Software and firmware

Software and firmware should be updated before using the server for the first time, unless any installed software or components require an older version.

For system software and firmware updates, use one of the following sources:

- Download the SPP ("Service Pack for ProLiant" on page 173) from the Hewlett Packard Enterprise website (<http://www.hpe.com/servers/spp/download>).

- Download individual drivers, firmware, or other systems software components from the server product page in the Hewlett Packard Enterprise Support Center website (<http://www.hpe.com/support/hpesc>).

## Operating System Version Support

For information about specific versions of a supported operating system, refer to the operating system support matrix (<http://www.hpe.com/info/ossupport>).

## Version control

The VCRM and VCA are web-enabled Insight Management Agents tools that SIM uses to schedule software update tasks to the entire enterprise.

- VCRM manages the repository for SPP. Administrators can view the SPP contents or configure VCRM to automatically update the repository with internet downloads of the latest software and firmware from Hewlett Packard Enterprise.
- VCA compares installed software versions on the node with updates available in the VCRM managed repository. Administrators configure VCA to point to a repository managed by VCRM.

For more information about version control tools, see the *Systems Insight Manager User Guide*, the *Version Control Agent User Guide*, and the *Version Control Repository Manager User Guide* on the Hewlett Packard Enterprise website (<http://www.hpe.com/info/enterprise/docs>).

1. Select **HP Insight Management** from the available options in Products and Solutions.
2. Select **HP Version Control** from the available options in Insight Management.
3. Download the latest document.

## Operating systems and virtualization software support for ProLiant servers

For information about specific versions of a supported operating system, see the Hewlett Packard Enterprise website (<http://www.hpe.com/info/ossupport>).

## HPE Technology Service Portfolio

Connect to Hewlett Packard Enterprise for assistance on the journey to the new style of IT. The Hewlett Packard Enterprise Technology Services delivers confidence and reduces risk to help you realize agility and stability in your IT infrastructure.

Utilize our consulting expertise in the areas of private or hybrid cloud computing, big data and mobility requirements, improving data center infrastructure and better use of today's server, storage and networking technology. For more information, see the Hewlett Packard Enterprise website (<http://www.hpe.com/services/consulting>).

Our support portfolio covers services for server, storage and networking hardware and software plus the leading industry standard operating systems. Let us work proactively with you to prevent problems. Our flexible choices of hardware and software support coverage windows and response times help resolve problems faster, reduce unplanned outages and free your staff for more important tasks. For more information, see the Hewlett Packard Enterprise website (<http://www.hpe.com/services/support>).

Tap into our knowledge, expertise, innovation and world-class services to achieve better results. Access and apply technology in new ways to optimize your operations and you'll be positioned for success.

## Change control and proactive notification

Hewlett Packard Enterprise offers Change Control and Proactive Notification to notify customers 30 to 60 days in advance of upcoming hardware and software changes on Hewlett Packard Enterprise commercial products.

For more information, see the Hewlett Packard Enterprise website (<http://www.hpe.com/info/pcn>).

# Troubleshooting

## Troubleshooting resources

The *HPE ProLiant Gen9 Troubleshooting Guide, Volume I: Troubleshooting* provides procedures for resolving common problems and comprehensive courses of action for fault isolation and identification, issue resolution, and software maintenance on ProLiant servers and server blades. To view the guide, select a language:

- English ([http://www.hpe.com/support/Gen9\\_TSG\\_en](http://www.hpe.com/support/Gen9_TSG_en))
- French ([http://www.hpe.com/support/Gen9\\_TSG\\_fr](http://www.hpe.com/support/Gen9_TSG_fr))
- Spanish ([http://www.hpe.com/support/Gen9\\_TSG\\_es](http://www.hpe.com/support/Gen9_TSG_es))
- German ([http://www.hpe.com/support/Gen9\\_TSG\\_de](http://www.hpe.com/support/Gen9_TSG_de))
- Japanese ([http://www.hpe.com/support/Gen9\\_TSG\\_ja](http://www.hpe.com/support/Gen9_TSG_ja))
- Simplified Chinese ([http://www.hpe.com/support/Gen9\\_TSG\\_zh\\_cn](http://www.hpe.com/support/Gen9_TSG_zh_cn))

The *HPE ProLiant Gen9 Troubleshooting Guide, Volume II: Error Messages* provides a list of error messages and information to assist with interpreting and resolving error messages on ProLiant servers and server blades. To view the guide, select a language:

- English ([http://www.hpe.com/support/Gen9\\_EMG\\_en](http://www.hpe.com/support/Gen9_EMG_en))
- French ([http://www.hpe.com/support/Gen9\\_EMG\\_fr](http://www.hpe.com/support/Gen9_EMG_fr))
- Spanish ([http://www.hpe.com/support/Gen9\\_EMG\\_es](http://www.hpe.com/support/Gen9_EMG_es))
- German ([http://www.hpe.com/support/Gen9\\_EMG\\_de](http://www.hpe.com/support/Gen9_EMG_de))
- Japanese ([http://www.hpe.com/support/Gen9\\_EMG\\_ja](http://www.hpe.com/support/Gen9_EMG_ja))
- Simplified Chinese ([http://www.hpe.com/support/Gen9\\_EMG\\_zh\\_cn](http://www.hpe.com/support/Gen9_EMG_zh_cn))

# Battery replacement

If the server no longer automatically displays the correct date and time, you may need to replace the battery that provides power to the real-time clock.



**WARNING:** The computer contains an internal lithium manganese dioxide, a vanadium pentoxide, or an alkaline battery pack. A risk of fire and burns exists if the battery pack is not properly handled. To reduce the risk of personal injury:

- Do not attempt to recharge the battery.
- Do not expose the battery to temperatures higher than 60°C (140°F).
- Do not disassemble, crush, puncture, short external contacts, or dispose of in fire or water.
- Replace only with the spare designated for this product.

To remove the component:

1. Power down the server (on page 26).
2. Remove all power:
  - a. Disconnect each power cord from the power source.
  - b. Disconnect each power cord from the server.
3. Do one of the following:
  - Extend the server from the rack (on page 26).
  - Remove the server from the rack (on page 27).
4. Remove the access panel (on page 27).
5. If installed, remove the secondary PCIe riser cage ("[3-slot PCI riser cage option](#)" on page 75).
6. Locate the battery ("[System board components](#)" on page 17).
7. Remove the battery.

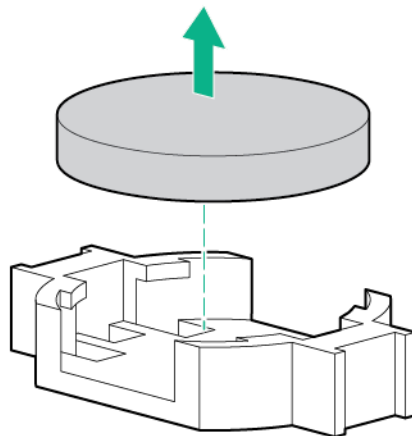

To replace the component, reverse the removal procedure.

For more information about battery replacement or proper disposal, contact an authorized reseller or an authorized service provider.



# Warranty and regulatory information

## Warranty information

HPE ProLiant and x86 Servers and Options

(<http://www.hpe.com/support/ProLiantServers-Warranties>)

HPE Enterprise Servers (<http://www.hpe.com/support/EnterpriseServers-Warranties>)

HPE Storage Products (<http://www.hpe.com/support/Storage-Warranties>)

HPE Networking Products (<http://www.hpe.com/support/Networking-Warranties>)

## Regulatory information

### Safety and regulatory compliance

For important safety, environmental, and regulatory information, see *Safety and Compliance Information for Server, Storage, Power, Networking, and Rack Products*, available at the Hewlett Packard Enterprise website (<http://www.hpe.com/support/Safety-Compliance-EnterpriseProducts>).

### Belarus Kazakhstan Russia marking



Manufacturer and Local Representative Information

**Manufacturer information:**

Hewlett Packard Enterprise Company, 3000 Hanover Street, Palo Alto, CA 94304 U.S.

**Local representative information Russian:**

- **Russia:**

ООО «Хьюлетт Паккард Энтерпрайз», Российская Федерация, 125171, г. Москва, Ленинградское шоссе, 16А, стр.3, Телефон/факс: +7 495 797 35 00

- **Belarus:**

ИООО «Хьюлетт-Паккард Бел», Республика Беларусь, 220030, г. Минск, ул. Интернациональная, 36-1, Телефон/факс: +375 17 392 28 20

- **Kazakhstan:**

ТОО «Хьюлетт-Паккард (К)», Республика Казахстан, 050040, г. Алматы, Бостандыкский район, проспект Аль-Фараби, 77/7, Телефон/факс: + 7 727 355 35 52

#### Local representative information Kazakh:

- **Russia:**

ЖШС "Хьюлетт Паккард Энтерпрайз", Ресей Федерациясы, 125171,  
Мәскеу, Ленинград тас жолы, 16А блок 3, Телефон/факс: +7 495 797 35 00

- **Belarus:**

«HEWLETT-PACKARD Bel» ЖШС, Беларусь Республикасы, 220030, Минск қ.,  
Интернациональная көшесі, 36/1, Телефон/факс: +375 17 392 28 20

- **Kazakhstan:**

ЖШС «Хьюлетт-Паккард (К)», Қазақстан Республикасы, 050040, Алматы қ.,  
Бостандық ауданы, Әл-Фараби даңғылы, 77/7, Телефон/факс: +7 727 355 35 52

#### Manufacturing date:

The manufacturing date is defined by the serial number.

CCSYWWZZZZ (serial number format for this product)

Valid date formats include:

- YWW, where Y indicates the year counting from within each new decade, with 2000 as the starting point; for example, 238: 2 for 2002 and 38 for the week of September 9. In addition, 2010 is indicated by 0, 2011 by 1, 2012 by 2, 2013 by 3, and so forth.
- YYWW, where YY indicates the year, using a base year of 2000; for example, 0238: 02 for 2002 and 38 for the week of September 9.

## Turkey RoHS material content declaration

Türkiye Cumhuriyeti: EEE Yönetmeliğine Uygundur

## Ukraine RoHS material content declaration

Обладнання відповідає вимогам Технічного регламенту щодо обмеження використання деяких небезпечних речовин в електричному та електронному обладнанні, затвердженого постановою Кабінету Міністрів України від 3 грудня 2008 № 1057

# Specifications

## Environmental specifications

Specification	Value
<b>Temperature range*</b>	—
Operating	10°C to 35°C (50°F to 95°F)
Nonoperating	-30°C to 60°C (-22°F to 140°F)
<b>Relative humidity (noncondensing)</b>	—
Operating	Minimum to be the higher (more moisture) of -12°C (10.4°F) dew point or 8% relative humidity Maximum to be 24°C (75.2°F) dew point or 90% relative humidity
Nonoperating	5% to 95% 38.7°C (101.7°F), maximum wet bulb temperature

\* All temperature ratings shown are for sea level. An altitude derating of 1.0°C per 304.8 m (1.8°F per 1000 ft) to 3048 m (10,000 ft) is applicable. No direct sunlight allowed. Maximum rate of change is 20°C per hour (36°F per hour). The upper limit and rate of change might be limited by the type and number of options installed.

For certain approved hardware configurations, the supported system inlet temperature range is extended:

- 5°C to 10°C (41°F to 50°F) and 35°C to 40°C (95°F to 104°F) at sea level with an altitude derating of 1.0°C per every 175 m (1.8°F per every 574 ft) above 900 m (2953 ft) to a maximum of 3048 m (10,000 ft).
- 40°C to 45°C (104°F to 113°F) at sea level with an altitude derating of 1.0°C per every 125 m (1.8°F per every 410 ft) above 900 m (2953 ft) to a maximum of 3048 m (10,000 ft).

The approved hardware configurations for this system are listed on the Hewlett Packard Enterprise website (<http://www.hpe.com/servers/ASHRAE>).

## Mechanical specifications

Specification	Value
Height	8.73 cm (3.44 in)
Depth, SFF	67.94 cm (26.75 in)
Depth, LFF	73.02 cm (28.75 in)
Width	44.54 cm (17.54 in)
Weight (maximum—all SFF drives)*	14.7 kg (32.6 lb)
Weight (minimum—one LFF drive)**	23.6 kg (51.5 lb)

\*The SFF configuration includes the following components:

- SFF drive (1)

- Drive blanks (7)
- Drive bay blanks for bays 1 and 2 (2)
- Fan assemblies (4)
- Fan blanks (2)
- Standard heatsink (1)
- 1P air baffle (1)
- X8 HPE Flexible Smart Array Controller (1)
- Primary riser cage (1)
- Secondary riser cage blank (1)
- Power supply (1)
- Power supply blank (1)
- Cables for the above components

\*\*The LFF configuration includes the following components:

- LFF drives (12)
- Fan assemblies (6)
- SE heatsinks (2)
- 2P air baffle (1)
- X8 HPE Flexible Smart Array Controller (1)
- Primary riser cage (1)
- Secondary riser cage (1)
- Power supplies (2)
- Cables for the above components

The 12 LFF configuration does not contain a rear three-bay LFF drive cage option.

## Power supply specifications

Depending on installed options, the server is configured with one of the following power supplies:

- HPE 500W Flex Slot Platinum Hot-plug Power Supply
- HPE 800W Flex Slot Platinum Hot-plug Power Supply (on page 189)
- HPE 800W Flex Slot Titanium Plus Hot-plug Power Supply (on page 190)
- HPE 800W Flex Slot Universal Hot-plug Power Supply (on page 190)
- HPE 800W Flex Slot -48VDC Hot-plug Power Supply (on page 191)
- HPE 1400W Flex Slot Platinum Plus Hot-plug Power Supply (on page 192)

For detailed power supply specifications, see the QuickSpecs on the Hewlett Packard Enterprise website (<http://www.hpe.com/info/proliant/powersupply>).

## HPE 500W Flex Slot Platinum Hot-plug Power Supply

Specification	Value
<b>Input requirements</b>	
Rated input voltage	100 to 127 VAC 200 to 240 VAC 240 VDC for China only
Rated input frequency	50 Hz to 60 Hz Not applicable to 240 VDC
Rated input current	5.8 A at 100 VAC 2.8 A at 200 VAC 2.4 A at 240 VDC for China only
Maximum rated input power	580 W at 100 VAC 560 W at 200 VAC 576 W at 240 VDC for China only
BTUs per hour	1979 at 100 VAC 1911 at 200 VAC 1965 at 240 VDC for China only
<b>Power supply output</b>	
Rated steady-state power	500 W at 100 VAC to 127 VAC input 500 W at 200 VAC to 240 VAC input 500 W at 240 VDC input for China only
Maximum peak power	500 W at 100 VAC to 127 VAC input 500 W at 200 VAC to 240 VAC input 500 W at 240 VDC input for China only

## HPE 800W Flex Slot Platinum Hot-plug Power Supply

Specification	Value
<b>Input requirements</b>	
Rated input voltage	100 to 127 VAC 200 to 240 VAC 240 VDC for China only
Rated input frequency	50 Hz to 60 Hz Not applicable to 240VDC
Rated input current	9.4 A at 100 VAC 4.5 A at 200 VAC 3.8 A at 240 VDC for China only
Maximum rated input power	940 W at 100 VAC 900 W at 200 VAC 912 W at 240 VDC for China only
BTUs per hour	3207 at 100 VAC 3071 at 200 VAC 3112 at 240 for China only
<b>Power supply output</b>	
Rated steady-state power	800 W at 100 VAC to 127 VAC input 800 W at 200 VAC to 240 VAC

	input 800 W at 240 VDC input for China only
Maximum peak power	800 W at 100 VAC to 127 VAC input 800 W at 200 VAC to 240 VAC input 800 W at 240 VDC input for China only

## HPE 800W Flex Slot Titanium Plus Hot-plug Power Supply

Specification	Value
<b>Input requirements</b>	
Rated input voltage	200 to 240 V AC 240 VDC for China only
Rated input frequency	50 Hz to 60 Hz Not applicable to 240 VDC
Rated input current	4.35 A at 200 VAC 3.62 A at 240 VAC 3.62 A at 240 VDC for China only
Maximum rated input power	870 W at 200 VAC 870 W at 240 VAC 870 W at 240 VDC for China only
BTUs per hour	2969 at 200 VAC 2969 at 240 VAC 2969 at 240 VDC for China only
<b>Power supply output</b>	
Rated steady-state power	800 W at 200 VAC to 240 VAC input 800 W at 240 VDC input for China only
Maximum peak power	800 W at 200 VAC to 240 VAC input 800 W at 240 VDC input for China only

## HPE 800W Flex Slot Universal Hot-plug Power Supply

Specification	Value
<b>Input requirements</b>	
Rated input voltage	200 V to 277 V AC 380 VDC
Rated input frequency	50 Hz–60 Hz
Rated input current	4.5 A at 200 V AC 3.2 A at 277 V AC 2.3 A at 380 VDC
Maximum rated input power	900 W at 200 VAC 887 W at 277 VAC 874 W at 380 VDC
BTUs per hour	3071 at 200 VAC 3026 at 277 VAC 2982 at 380 VDC

<b>Power supply output</b>	
Rated steady-state power	800 W at 200 VAC to 277 VAC input 800 W at 380 VDC input
Maximum peak power	800 W at 200 VAC to 277 VAC input 800 W at 380 VDC input

## HPE 800W Flex Slot -48VDC Hot-plug Power Supply

<b>Specification</b>	<b>Value</b>
<b>Input requirements</b>	
Rated input voltage	-40 VDC to -72 VDC -48 VDC nominal input
Rated input current	26 A at -40 VDC input 19 A at -48 VDC input, nominal input 12.4 A at -72 VDC input
Rated input power (W)	936 W at -40 VDC input 912 W at -48 VDC input, nominal input 900 W at -72 VDC input
Rated input power (BTUs per hour)	3194 at -40 VDC input 3112 at -48 VDC input, nominal input 3071 at -72 VDC input
<b>Power supply output</b>	
Rated steady-state power (W)	800 W at -40 VDC to -72 VDC
Maximum peak power (W)	800 W at -40 VDC to -72 VDC



**WARNING:** To reduce the risk of electric shock or energy hazards:

- This equipment must be installed by trained service personnel, as defined by the NEC and IEC 60950-1, Second Edition, the standard for Safety of Information Technology Equipment.
- Connect the equipment to a reliably grounded Secondary circuit source. A Secondary circuit has no direct connection to a Primary circuit and derives its power from a transformer, converter, or equivalent isolation device.
- The branch circuit overcurrent protection must be rated 27 A.



**CAUTION:** This equipment is designed to permit the connection of the earthed conductor of the DC supply circuit to the earthing conductor at the equipment.

If this connection is made, all of the following must be met:

- This equipment must be connected directly to the DC supply system earthing electrode conductor or to a bonding jumper from an earthing terminal bar or bus to which the DC supply system earthing electrode conductor is connected.
- This equipment must be located in the same immediate area (such as adjacent cabinets) as any other equipment that has a connection between the earthed conductor of the same DC supply circuit and the earthing conductor, and also the point of earthing of the DC system. The DC system must be earthed elsewhere.
- The DC supply source is to be located within the same premises as the equipment.
- Switching or disconnecting devices must not be in the earthed circuit conductor between the DC source and the point of connection of the earthing electrode conductor.

# HPE 1400W Flex Slot Platinum Plus Hot-plug Power Supply

Specification	Value
<b>Input requirements</b>	
Rated input voltage	200 to 240 VAC 240 VDC for China only
Rated input frequency	50 Hz to 60 Hz Not applicable to 240 VDC
Rated input current	8.0 A at 200 VAC 6.7 A at 240 VAC 6.7 A at 240 VDC for China only
Maximum rated input power	1600 W at 200 VAC 1600 W at 240 VAC 1600 W at 240 VDC for China only
BTUs per hour	5459 at 200 VAC 5459 at 240 VAC 5459 at 240 VDC for China only
<b>Power supply output</b>	
Rated steady-state power	1400 W at 200 VAC to 240 VAC input 1400 W at 240 VDC input for China only
Maximum peak power	1400 W at 200 VAC to 240 VAC input 1400 W at 240 VDC input for China only

# HPE 750W Flex Slot Hot-plug Battery Backup Module

Specification	Value
Rated input voltage	12 V DC
Dual input	Yes
Battery replaceable	No
Built-in power supply	No
Nominal charge current	0.77 A
Maximum discharge current	62.50 A
Maximum discharge power	750 W
Maximum runtime	
– Full load, 750 W	>60 seconds
– 75% load, 564 W	145 seconds
– 50% load, 375 W	220 seconds
– 25% load, 187 W	300 seconds (limited by user)

## Hot-plug power supply calculations

For hot-plug power supply specifications and calculators to determine electrical and heat loading for the server, see the Hewlett Packard Enterprise Power Advisor website (<http://www.hpe.com/info/poweradvisor/online>).



# Support and other resources

## Accessing Hewlett Packard Enterprise Support

- For live assistance, go to the Contact Hewlett Packard Enterprise Worldwide website (<http://www.hpe.com/assistance>).
- To access documentation and support services, go to the Hewlett Packard Enterprise Support Center website (<http://www.hpe.com/support/hpesc>).

## Information to collect

- Technical support registration number (if applicable)
- Product name, model or version, and serial number
- Operating system name and version
- Firmware version
- Error messages
- Product-specific reports and logs
- Add-on products or components
- Third-party products or components

## Accessing updates

- Some software products provide a mechanism for accessing software updates through the product interface. Review your product documentation to identify the recommended software update method.
- To download product updates, go to either of the following:
  - Hewlett Packard Enterprise Support Center **Get connected with updates** page (<http://www.hpe.com/support/e-updates>)
  - Software Depot website (<http://www.hpe.com/support/softwaredepot>)
- To view and update your entitlements, and to link your contracts and warranties with your profile, go to the Hewlett Packard Enterprise Support Center **More Information on Access to Support Materials** page (<http://www.hpe.com/support/AccessToSupportMaterials>).



**IMPORTANT:** Access to some updates might require product entitlement when accessed through the Hewlett Packard Enterprise Support Center. You must have an HP Passport set up with relevant entitlements.

## Websites

- Hewlett Packard Enterprise Information Library (<http://www.hpe.com/info/enterprise/docs>)
- Hewlett Packard Enterprise Support Center (<http://www.hpe.com/support/hpesc>)
- Contact Hewlett Packard Enterprise Worldwide (<http://www.hpe.com/assistance>)

- Subscription Service/Support Alerts (<http://www.hpe.com/support/e-updates>)
- Software Depot (<http://www.hpe.com/support/softwaredepot>)
- Customer Self Repair (<http://www.hpe.com/support/selfrepair>)
- Insight Remote Support (<http://www.hpe.com/info/insightremotesupport/docs>)
- Serviceguard Solutions for HP-UX (<http://www.hpe.com/info/hpux-serviceguard-docs>)
- Single Point of Connectivity Knowledge (SPOCK) Storage compatibility matrix (<http://www.hpe.com/storage/spock>)
- Storage white papers and analyst reports (<http://www.hpe.com/storage/whitepapers>)

## Customer Self Repair

Hewlett Packard Enterprise products are designed with many Customer Self Repair (CSR) parts to minimize repair time and allow for greater flexibility in performing defective parts replacement. If during the diagnosis period Hewlett Packard Enterprise (or Hewlett Packard Enterprise service providers or service partners) identifies that the repair can be accomplished by the use of a CSR part, Hewlett Packard Enterprise will ship that part directly to you for replacement. There are two categories of CSR parts:

- **Mandatory**—Parts for which customer self repair is mandatory. If you request Hewlett Packard Enterprise to replace these parts, you will be charged for the travel and labor costs of this service.
- **Optional**—Parts for which customer self repair is optional. These parts are also designed for customer self repair. If, however, you require that Hewlett Packard Enterprise replace them for you, there may or may not be additional charges, depending on the type of warranty service designated for your product.

**NOTE:** Some Hewlett Packard Enterprise parts are not designed for customer self repair. In order to satisfy the customer warranty, Hewlett Packard Enterprise requires that an authorized service provider replace the part. These parts are identified as "No" in the Illustrated Parts Catalog.

Based on availability and where geography permits, CSR parts will be shipped for next business day delivery. Same day or four-hour delivery may be offered at an additional charge where geography permits. If assistance is required, you can call the Hewlett Packard Enterprise Support Center and a technician will help you over the telephone. Hewlett Packard Enterprise specifies in the materials shipped with a replacement CSR part whether a defective part must be returned to Hewlett Packard Enterprise. In cases where it is required to return the defective part to Hewlett Packard Enterprise, you must ship the defective part back to Hewlett Packard Enterprise within a defined period of time, normally five (5) business days. The defective part must be returned with the associated documentation in the provided shipping material. Failure to return the defective part may result in Hewlett Packard Enterprise billing you for the replacement. With a customer self repair, Hewlett Packard Enterprise will pay all shipping and part return costs and determine the courier/carrier to be used.

For more information about the Hewlett Packard Enterprise CSR program, contact your local service provider. For the North American program, go to the Hewlett Packard Enterprise CSR website (<http://www.hpe.com/support/selfrepair>).

## Réparation par le client (CSR)

Les produits Hewlett Packard Enterprise comportent de nombreuses pièces CSR (Customer Self Repair = réparation par le client) afin de minimiser les délais de réparation et faciliter le remplacement des pièces défectueuses. Si pendant la période de diagnostic, Hewlett Packard Enterprise (ou ses partenaires ou mainteneurs agréés) détermine que la réparation peut être effectuée à l'aide d'une pièce CSR, Hewlett Packard Enterprise vous l'envoie directement. Il existe deux catégories de pièces CSR :

- **Obligatoire**—Pièces pour lesquelles la réparation par le client est obligatoire. Si vous demandez à Hewlett Packard Enterprise de remplacer ces pièces, les coûts de déplacement et main d'œuvre du service vous seront facturés.
- **Facultatif**—Pièces pour lesquelles la réparation par le client est facultative. Ces pièces sont également conçues pour permettre au client d'effectuer lui-même la réparation. Toutefois, si vous demandez à Hewlett Packard Enterprise de remplacer ces pièces, l'intervention peut ou non vous être facturée, selon le type de garantie applicable à votre produit.

**REMARQUE:** Certaines pièces Hewlett Packard Enterprise ne sont pas conçues pour permettre au client d'effectuer lui-même la réparation. Pour que la garantie puisse s'appliquer, Hewlett Packard Enterprise exige que le remplacement de la pièce soit effectué par un Mainteneur Agréé. Ces pièces sont identifiées par la mention "Non" dans le Catalogue illustré.

Les pièces CSR sont livrées le jour ouvré suivant, dans la limite des stocks disponibles et selon votre situation géographique. Si votre situation géographique le permet et que vous demandez une livraison le jour même ou dans les 4 heures, celle-ci vous sera facturée. Pour toute assistance, appelez le Centre d'assistance Hewlett Packard Enterprise pour qu'un technicien vous aide au téléphone. Dans les documents envoyés avec la pièce de rechange CSR, Hewlett Packard Enterprise précise s'il est nécessaire de lui retourner la pièce défectueuse. Si c'est le cas, vous devez le faire dans le délai indiqué, généralement cinq (5) jours ouvrés. La pièce et sa documentation doivent être retournées dans l'emballage fourni. Si vous ne retournez pas la pièce défectueuse, Hewlett Packard Enterprise se réserve le droit de vous facturer les coûts de remplacement. Dans le cas d'une pièce CSR, Hewlett Packard Enterprise supporte l'ensemble des frais d'expédition et de retour, et détermine la société de courses ou le transporteur à utiliser.

Pour plus d'informations sur le programme CSR de Hewlett Packard Enterprise, contactez votre Mainteneur Agréé local. Pour plus d'informations sur ce programme en Amérique du Nord, consultez le site Web Hewlett Packard Enterprise (<http://www.hpe.com/support/selfrepair>).

## Riparazione da parte del cliente

Per abbreviare i tempi di riparazione e garantire una maggiore flessibilità nella sostituzione di parti difettose, i prodotti Hewlett Packard Enterprise sono realizzati con numerosi componenti che possono essere riparati direttamente dal cliente (CSR, Customer Self Repair). Se in fase di diagnostica Hewlett Packard Enterprise (o un centro di servizi o di assistenza Hewlett Packard Enterprise) identifica il guasto come riparabile mediante un ricambio CSR, Hewlett Packard Enterprise lo spedisce direttamente al cliente per la sostituzione. Vi sono due categorie di parti CSR:

- **Obbligatorie**—Parti che devono essere necessariamente riparate dal cliente. Se il cliente ne affida la riparazione ad Hewlett Packard Enterprise, deve sostenere le spese di spedizione e di manodopera per il servizio.
- **Opzionali**—Parti la cui riparazione da parte del cliente è facoltativa. Si tratta comunque di componenti progettati per questo scopo. Se tuttavia il cliente ne richiede la sostituzione ad Hewlett Packard Enterprise, potrebbe dover sostenere spese aggiuntive a seconda del tipo di garanzia previsto per il prodotto.

**NOTA:** alcuni componenti Hewlett Packard Enterprise non sono progettati per la riparazione da parte del cliente. Per rispettare la garanzia, Hewlett Packard Enterprise richiede che queste parti siano sostituite da un centro di assistenza autorizzato. Tali parti sono identificate da un "No" nel Catalogo illustrato dei componenti.

In base alla disponibilità e alla località geografica, le parti CSR vengono spedite con consegna entro il giorno lavorativo seguente. La consegna nel giorno stesso o entro quattro ore è offerta con un supplemento di costo solo in alcune zone. In caso di necessità si può richiedere l'assistenza telefonica di un addetto del centro di supporto tecnico Hewlett Packard Enterprise. Nel materiale fornito con una parte di ricambio CSR, Hewlett Packard Enterprise specifica se il cliente deve restituire dei componenti. Qualora sia richiesta la resa ad Hewlett Packard Enterprise del componente difettoso, lo si deve spedire ad Hewlett Packard Enterprise entro un determinato periodo di tempo, generalmente cinque (5) giorni lavorativi. Il componente difettoso deve essere restituito con la documentazione associata nell'imballo di

spedizione fornito. La mancata restituzione del componente può comportare la fatturazione del ricambio da parte di Hewlett Packard Enterprise. Nel caso di riparazione da parte del cliente, Hewlett Packard Enterprise sostiene tutte le spese di spedizione e resa e sceglie il corriere/vettore da utilizzare.

Per ulteriori informazioni sul programma CSR di Hewlett Packard Enterprise, contattare il centro di assistenza di zona. Per il programma in Nord America fare riferimento al sito Web (<http://www.hpe.com/support/selfrepair>).

## Customer Self Repair

Hewlett Packard Enterprise Produkte enthalten viele CSR-Teile (Customer Self Repair), um Reparaturzeiten zu minimieren und höhere Flexibilität beim Austausch defekter Bauteile zu ermöglichen. Wenn Hewlett Packard Enterprise (oder ein Hewlett Packard Enterprise Servicepartner) bei der Diagnose feststellt, dass das Produkt mithilfe eines CSR-Teils repariert werden kann, sendet Ihnen Hewlett Packard Enterprise dieses Bauteil zum Austausch direkt zu. CSR-Teile werden in zwei Kategorien unterteilt:

- **Zwingend**—Teile, für die das Customer Self Repair-Verfahren zwingend vorgegeben ist. Wenn Sie den Austausch dieser Teile von Hewlett Packard Enterprise vornehmen lassen, werden Ihnen die Anfahrt- und Arbeitskosten für diesen Service berechnet.
- **Optional**—Teile, für die das Customer Self Repair-Verfahren optional ist. Diese Teile sind auch für Customer Self Repair ausgelegt. Wenn Sie jedoch den Austausch dieser Teile von Hewlett Packard Enterprise vornehmen lassen möchten, können bei diesem Service je nach den für Ihr Produkt vorgesehenen Garantiebedingungen zusätzliche Kosten anfallen.

**HINWEIS:** Einige Hewlett Packard Enterprise Teile sind nicht für Customer Self Repair ausgelegt. Um den Garantieanspruch des Kunden zu erfüllen, muss das Teil von einem Hewlett Packard Enterprise Servicepartner ersetzt werden. Im illustrierten Teilekatalog sind diese Teile mit „No“ bzw. „Nein“ gekennzeichnet.

CSR-Teile werden abhängig von der Verfügbarkeit und vom Lieferziel am folgenden Geschäftstag geliefert. Für bestimmte Standorte ist eine Lieferung am selben Tag oder innerhalb von vier Stunden gegen einen Aufpreis verfügbar. Wenn Sie Hilfe benötigen, können Sie das Hewlett Packard Enterprise Support Center anrufen und sich von einem Mitarbeiter per Telefon helfen lassen. Den Materialien von Hewlett Packard Enterprise, die mit einem CSR-Ersatzteil geliefert werden, können Sie entnehmen, ob das defekte Teil an Hewlett Packard Enterprise zurückgeschickt werden muss. Wenn es erforderlich ist, das defekte Teil an Hewlett Packard Enterprise zurückzuschicken, müssen Sie dies innerhalb eines vorgegebenen Zeitraums tun, in der Regel innerhalb von fünf (5) Geschäftstagen. Das defekte Teil muss mit der zugehörigen Dokumentation in der Verpackung zurückgeschickt werden, die im Lieferumfang enthalten ist. Wenn Sie das defekte Teil nicht zurückschicken, kann Hewlett Packard Enterprise Ihnen das Ersatzteil in Rechnung stellen. Im Falle von Customer Self Repair kommt Hewlett Packard Enterprise für alle Kosten für die Lieferung und Rücksendung auf und bestimmt den Kurier-/Frachtdienst.

Weitere Informationen über das Hewlett Packard Enterprise Customer Self Repair Programm erhalten Sie von Ihrem Servicepartner vor Ort. Informationen über das CSR-Programm in Nordamerika finden Sie auf der Hewlett Packard Enterprise Website unter (<http://www.hpe.com/support/selfrepair>).

## Reparaciones del propio cliente

Los productos de Hewlett Packard Enterprise incluyen muchos componentes que el propio usuario puede reemplazar (Customer Self Repair, CSR) para minimizar el tiempo de reparación y ofrecer una mayor flexibilidad a la hora de realizar sustituciones de componentes defectuosos. Si, durante la fase de diagnóstico, Hewlett Packard Enterprise (o los proveedores o socios de servicio de Hewlett Packard Enterprise) identifica que una reparación puede llevarse a cabo mediante el uso de un componente CSR, Hewlett Packard Enterprise le enviará dicho componente directamente para que realice su sustitución. Los componentes CSR se clasifican en dos categorías:

- **Obligatorio**—componentes cuya reparación por parte del usuario es obligatoria. Si solicita a Hewlett Packard Enterprise que realice la sustitución de estos componentes, tendrá que hacerse cargo de los gastos de desplazamiento y de mano de obra de dicho servicio.
- **Opcional**—componentes cuya reparación por parte del usuario es opcional. Estos componentes también están diseñados para que puedan ser reparados por el usuario. Sin embargo, si precisa que Hewlett Packard Enterprise realice su sustitución, puede o no conllevar costes adicionales, dependiendo del tipo de servicio de garantía correspondiente al producto.

**NOTA:** Algunos componentes de Hewlett Packard Enterprise no están diseñados para que puedan ser reparados por el usuario. Para que el usuario haga valer su garantía, Hewlett Packard Enterprise pone como condición que un proveedor de servicios autorizado realice la sustitución de estos componentes. Dichos componentes se identifican con la palabra "No" en el catálogo ilustrado de componentes.

Según la disponibilidad y la situación geográfica, los componentes CSR se enviarán para que lleguen a su destino al siguiente día laborable. Si la situación geográfica lo permite, se puede solicitar la entrega en el mismo día o en cuatro horas con un coste adicional. Si precisa asistencia técnica, puede llamar al Centro de asistencia técnica de Hewlett Packard Enterprise y recibirá ayuda telefónica por parte de un técnico. Con el envío de materiales para la sustitución de componentes CSR, Hewlett Packard Enterprise especificará si los componentes defectuosos deberán devolverse a Hewlett Packard Enterprise. En aquellos casos en los que sea necesario devolver algún componente a Hewlett Packard Enterprise, deberá hacerlo en el periodo de tiempo especificado, normalmente cinco días laborables. Los componentes defectuosos deberán devolverse con toda la documentación relacionada y con el embalaje de envío. Si no enviara el componente defectuoso requerido, Hewlett Packard Enterprise podrá cobrarle por el de sustitución. En el caso de todas sustituciones que lleve a cabo el cliente, Hewlett Packard Enterprise se hará cargo de todos los gastos de envío y devolución de componentes y escogerá la empresa de transporte que se utilice para dicho servicio.

Para obtener más información acerca del programa de Reparaciones del propio cliente de Hewlett Packard Enterprise, póngase en contacto con su proveedor de servicios local. Si está interesado en el programa para Norteamérica, visite la página web de Hewlett Packard Enterprise CSR (<http://www.hpe.com/support/selfrepair>).

## Customer Self Repair

Veel onderdelen in Hewlett Packard Enterprise producten zijn door de klant zelf te repareren, waardoor de reparatieduur tot een minimum beperkt kan blijven en de flexibiliteit in het vervangen van defecte onderdelen groter is. Deze onderdelen worden CSR-onderdelen (Customer Self Repair) genoemd. Als Hewlett Packard Enterprise (of een Hewlett Packard Enterprise Service Partner) bij de diagnose vaststelt dat de reparatie kan worden uitgevoerd met een CSR-onderdeel, verzendt Hewlett Packard Enterprise dat onderdeel rechtstreeks naar u, zodat u het defecte onderdeel daarmee kunt vervangen. Er zijn twee categorieën CSR-onderdelen:

- **Verplicht**—Onderdelen waarvoor reparatie door de klant verplicht is. Als u Hewlett Packard Enterprise verzoekt deze onderdelen voor u te vervangen, worden u voor deze service reiskosten en arbeidsloon in rekening gebracht.
- **Optioneel**—Onderdelen waarvoor reparatie door de klant optioneel is. Ook deze onderdelen zijn ontworpen voor reparatie door de klant. Als u echter Hewlett Packard Enterprise verzoekt deze onderdelen voor u te vervangen, kunnen daarvoor extra kosten in rekening worden gebracht, afhankelijk van het type garantieservice voor het product.

**OPMERKING:** Sommige Hewlett Packard Enterprise onderdelen zijn niet ontwikkeld voor reparatie door de klant. In verband met de garanti voorwaarden moet het onderdeel door een geautoriseerde Service Partner worden vervangen. Deze onderdelen worden in de geïllustreerde onderdelencatalogus aangemerkt met "Nee".

Afhankelijk van de leverbaarheid en de locatie worden CSR-onderdelen verzonden voor levering op de eerstvolgende werkdag. Levering op dezelfde dag of binnen vier uur kan tegen meerkosten worden aangeboden, indien dit mogelijk is gezien de locatie. Indien assistentie is gewenst, belt u het Hewlett Packard Enterprise Support Center om via de telefoon ondersteuning van een technicus te ontvangen.

Hewlett Packard Enterprise vermeldt in de documentatie bij het vervangende CSR-onderdeel of het defecte onderdeel aan Hewlett Packard Enterprise moet worden geretourneerd. Als het defecte onderdeel aan Hewlett Packard Enterprise moet worden teruggezonden, moet u het defecte onderdeel binnen een bepaalde periode, gewoonlijk vijf (5) werkdagen, retourneren aan Hewlett Packard Enterprise. Het defecte onderdeel moet met de bijbehorende documentatie worden geretourneerd in het meegeleverde verpakkingsmateriaal. Als u het defecte onderdeel niet terugzendt, kan Hewlett Packard Enterprise u voor het vervangende onderdeel kosten in rekening brengen. Bij reparatie door de klant betaalt Hewlett Packard Enterprise alle verzendkosten voor het vervangende en geretourneerde onderdeel en kiest Hewlett Packard Enterprise zelf welke koerier/transportonderneming hiervoor wordt gebruikt.

Neem contact op met een Service Partner voor meer informatie over het Customer Self Repair programma van Hewlett Packard Enterprise. Informatie over Service Partners vindt u op de Hewlett Packard Enterprise website (<http://www.hpe.com/support/selfrepair>).

## Reparo feito pelo cliente

Os produtos da Hewlett Packard Enterprise são projetados com muitas peças para reparo feito pelo cliente (CSR) de modo a minimizar o tempo de reparo e permitir maior flexibilidade na substituição de peças com defeito. Se, durante o período de diagnóstico, a Hewlett Packard Enterprise (ou fornecedores/parceiros da Hewlett Packard Enterprise) concluir que o reparo pode ser efetuado pelo uso de uma peça CSR, a Hewlett Packard Enterprise enviará a peça diretamente ao cliente. Há duas categorias de peças CSR:

- **Obrigatória**—Peças cujo reparo feito pelo cliente é obrigatório. Se desejar que a Hewlett Packard Enterprise substitua essas peças, serão cobradas as despesas de transporte e mão-de-obra do serviço.
- **Opcional**—Peças cujo reparo feito pelo cliente é opcional. Essas peças também são projetadas para o reparo feito pelo cliente. No entanto, se desejar que a Hewlett Packard Enterprise as substitua, pode haver ou não a cobrança de taxa adicional, dependendo do tipo de serviço de garantia destinado ao produto.

**OBSERVAÇÃO:** Algumas peças da Hewlett Packard Enterprise não são projetadas para o reparo feito pelo cliente. A fim de cumprir a garantia do cliente, a Hewlett Packard Enterprise exige que um técnico autorizado substitua a peça. Essas peças estão identificadas com a marca "No" (Não), no catálogo de peças ilustrado.

Conforme a disponibilidade e o local geográfico, as peças CSR serão enviadas no primeiro dia útil após o pedido. Onde as condições geográficas permitirem, a entrega no mesmo dia ou em quatro horas pode ser feita mediante uma taxa adicional. Se precisar de auxílio, entre em contato com o Centro de suporte técnico da Hewlett Packard Enterprise para que um técnico o ajude por telefone. A Hewlett Packard Enterprise especifica nos materiais fornecidos com a peça CSR de reposição se a peça com defeito deve ser devolvida à Hewlett Packard Enterprise. Nos casos em que isso for necessário, é preciso enviar a peça com defeito à Hewlett Packard Enterprise, você deverá enviar a peça com defeito de volta para a Hewlett Packard Enterprise dentro do período de tempo definido, normalmente em 5 (cinco) dias úteis. A peça com defeito deve ser enviada com a documentação correspondente no material de transporte fornecido. Caso não o faça, a Hewlett Packard Enterprise poderá cobrar a reposição. Para as peças de reparo feito pelo cliente, a Hewlett Packard Enterprise paga todas as despesas de transporte e de devolução da peça e determina a transportadora/serviço postal a ser utilizado.

Para obter mais informações sobre o programa de reparo feito pelo cliente da Hewlett Packard Enterprise, entre em contato com o fornecedor de serviços local. Para o programa norte-americano, visite o site da Hewlett Packard Enterprise (<http://www.hpe.com/support/selfrepair>).

## カスタマーセルフリペア

修理時間を短縮し、故障部品の交換における高い柔軟性を確保するために、Hewlett Packard Enterprise製品には多数のカスタマーセルフリペア（CSR）部品があります。診断の際に、CSR部品を使用すれば修理ができるとHewlett Packard Enterprise（Hewlett Packard EnterpriseまたはHewlett Packard Enterprise正規保守代理店）が判断した場合、Hewlett Packard Enterpriseはその部品を直接、お客様に発送し、お客様に交換していただきます。CSR部品には以下の2種類があります。

- **必須** - カスタマーセルフリペアが必須の部品。当該部品について、もしもお客様がHewlett Packard Enterpriseに交換作業を依頼される場合には、その修理サービスに関する交通費および人件費がお客様に請求されます。
- **任意** - カスタマーセルフリペアが任意である部品。この部品もカスタマーセルフリペア用です。当該部品について、もしもお客様がHewlett Packard Enterpriseに交換作業を依頼される場合には、お買い上げの製品に適用される保証サービス内容の範囲内においては、別途費用を負担していただくことなく保証サービスを受けることができます。

**注：** Hewlett Packard Enterprise製品の一部の部品は、カスタマーセルフリペアの対象外です。製品の保証を継続するためには、Hewlett Packard EnterpriseまたはHewlett Packard Enterprise正規保守代理店による交換作業が必須となります。部品カタログには、当該部品がカスタマーセルフリペア除外品である旨が記載されています。

部品供給が可能な場合、地域によっては、CSR部品を翌営業日に届くように発送します。また、地域によっては、追加費用を負担いただくことにより同日または4時間以内に届くように発送することも可能な場合があります。サポートが必要なときは、Hewlett Packard Enterpriseの修理受付窓口に電話していただければ、技術者が電話でアドバイスします。交換用のCSR部品または同梱物には、故障部品をHewlett Packard Enterpriseに返送する必要があるかどうかが表示されています。故障部品をHewlett Packard Enterpriseに返送する必要がある場合は、指定期限内（通常は5営業日以内）に故障部品をHewlett Packard Enterpriseに返送してください。故障部品を返送する場合は、届いた時の梱包箱に関連書類とともに入れてください。故障部品を返送しない場合、Hewlett Packard Enterpriseから部品費用が請求されます。カスタマーセルフリペアの際には、Hewlett Packard Enterpriseは送料および部品返送費を全額負担し、使用する宅配便会社や運送会社を指定します。

# 客户自行维修

Hewlett Packard Enterprise 产品提供许多客户自行维修 (CSR) 部件，以尽可能缩短维修时间和在更换缺陷部件方面提供更大的灵活性。如果在诊断期间 Hewlett Packard Enterprise (或 Hewlett Packard Enterprise 服务提供商或服务合作伙伴) 确定可以通过使用 CSR 部件完成维修，Hewlett Packard Enterprise 将直接把该部件发送给您进行更换。有两类 CSR 部件：

- **强制性的** — 要求客户必须自行维修的部件。如果您请求 Hewlett Packard Enterprise 更换这些部件，则必须为该服务支付差旅费和人工费用。
- **可选的** — 客户可以选择是否自行维修的部件。这些部件也是为客户自行维修设计的。不过，如果您要求 Hewlett Packard Enterprise 为您更换这些部件，则根据为您的产品指定的保修服务类型，Hewlett Packard Enterprise 可能收取或不再收取任何附加费用。

**注：**某些 Hewlett Packard Enterprise 部件的设计并未考虑客户自行维修。为了满足客户保修的需要，Hewlett Packard Enterprise 要求授权服务提供商更换相关部件。这些部件在部件图解目录中标记为“否”。

CSR 部件将在下一个工作日发运（取决于备货情况和允许的地理范围）。在允许的地理范围内，可在当天或四小时内发运，但要收取额外费用。如果需要帮助，您可以致电 Hewlett Packard Enterprise 技术支持中心，将会有技术人员通过电话为您提供帮助。Hewlett Packard Enterprise 会在随更换的 CSR 部件发运的材料中指明是否必须将有缺陷的部件返还给 Hewlett Packard Enterprise。如果要求您将有缺陷的部件返还给 Hewlett Packard Enterprise，那么您必须在规定的期限内（通常是五 (5) 个工作日）将缺陷部件发给 Hewlett Packard Enterprise。有缺陷的部件必须随所提供的发运材料中的相关文件一起返还。如果未能送还有缺陷的部件，Hewlett Packard Enterprise 可能会要求您支付更换费用。客户自行维修时，Hewlett Packard Enterprise 将承担所有相关运输和部件返回费用，并指定快递商/承运商。

有关 Hewlett Packard Enterprise 客户自行维修计划的详细信息，请与您当地的服务提供商联系。有关北美地区的计划，请访问 Hewlett Packard Enterprise 网站 (<http://www.hpe.com/support/selfrepair>)。

# 客戶自行維修

Hewlett Packard Enterprise 產品設計了許多「客戶自行維修」(CSR) 的零件以減少維修時間，並且使得更換瑕疵零件時能有更大的彈性。如果在診斷期間，Hewlett Packard Enterprise (或 Hewlett Packard Enterprise 服務供應商或維修夥伴) 辨認出此項維修工作可以藉由使用 CSR 零件來完成，則 Hewlett Packard Enterprise 將直接寄送該零件給您作更換。CSR 零件分為兩種類別：

- **強制的** — 客戶自行維修所使用的零件是強制的。如果您要求 Hewlett Packard Enterprise 更換這些零件，Hewlett Packard Enterprise 將會向您收取此服務所需的外出費用與勞動成本。
- **選購的** — 客戶自行維修所使用的零件是選購的。這些零件也設計用於客戶自行維修之用。不過，如果您要求 Hewlett Packard Enterprise 為您更換，則可能需要也可能不需要負擔額外的費用，端視針對此產品指定的保固服務類型而定。

**備註：**某些 Hewlett Packard Enterprise 零件沒有消費者可自行維修的設計。為符合客戶保固，Hewlett Packard Enterprise 需要授權的服務供應商更換零件。這些零件在圖示的零件目錄中，被標示為「否」。

基於材料取得及環境允許的情況下，CSR 零件將於下一個工作日以快遞寄送。在環境的允許下當天或四小時內送達，則可能需要額外的費用。若您需要協助，可致電 Hewlett Packard Enterprise 支援中心，會有一位技術人員透過電話來協助您。不論損壞的零件是否必須退回，Hewlett Packard Enterprise 皆會在與 CSR 替換零件一起運送的材料中註明。若要將損壞的零件退回 Hewlett Packard Enterprise，您必須在指定的一段時間內（通常為五 (5) 個工作天），將損壞的零件寄回 Hewlett Packard Enterprise。損壞的零件必須與寄送資料中隨附的相關技術文件一併退還。如果無法退還損壞的零件，Hewlett Packard Enterprise 可能要向您收取替換費用。針對客戶自行維修情形，Hewlett Packard Enterprise 將負責所有運費及零件退還費用，並指定使用何家快遞/貨運公司。

如需 Hewlett Packard Enterprise 的 CSR 方案詳細資訊，請連絡您當地的服務供應商。至於北美方案，請參閱 Hewlett Packard Enterprise 的 CSR 網站 [selfrepair](http://www.hpe.com/support/selfrepair) (<http://www.hpe.com/support/selfrepair>)。



## 고객 셀프 수리

Hewlett Packard Enterprise 제품은 수리 시간을 최소화하고 결함이 있는 부품 교체 시 더욱 융통성을 발휘할 수 있도록 하기 위해 고객 셀프 수리(CSR) 부품을 다량 사용하여 설계되었습니다. 진단 기간 동안 Hewlett Packard Enterprise(또는 Hewlett Packard Enterprise 서비스 공급업체 또는 서비스 협력업체)에서 CSR 부품을 사용하여 수리가 가능하다고 판단되면 Hewlett Packard Enterprise는 해당 부품을 바로 사용자에게 보내어 사용자가 교체할 수 있도록 합니다. CSR 부품에는 두 가지 종류가 있습니다.

- 필수 - 고객 셀프 수리가 의무 사항인 필수 부품. 사용자가 Hewlett Packard Enterprise에 이 부품의 교체를 요청할 경우 이 서비스에 대한 출장비 및 작업비가 청구됩니다.
- 선택 사항 - 고객 셀프 수리가 선택 사항인 부품. 이 부품들도 고객 셀프 수리가 가능하도록 설계되었습니다. 하지만 사용자가 Hewlett Packard Enterprise에 이 부품의 교체를 요청할 경우 사용자가 구입한 제품에 해당하는 보증 서비스 유형에 따라 추가 비용 없이 교체가 가능할 수 있습니다.

**참고:** 일부 Hewlett Packard Enterprise 부품은 고객 셀프 수리가 불가능하도록 설계되었습니다. Hewlett Packard Enterprise는 만족스러운 고객 보증을 위해 공인 서비스 제공업체를 통해 부품을 교체하도록 하고 있습니다. 이러한 부품들은 Illustrated Parts Catalog에 "No"라고 표시되어 있습니다.

CSR 부품은 재고 상태와 지리적 조건이 허용하는 경우 다음 영업일 납품이 가능하도록 배송이 이루어집니다. 지리적 조건이 허용하는 경우 추가 비용이 청구되는 조건으로 당일 또는 4시간 배송이 가능할 수도 있습니다. 도움이 필요하시면 Hewlett Packard Enterprise Support Center로 전화하십시오. 전문 기술자가 전화로 도움을 줄 것입니다. Hewlett Packard Enterprise는 결함이 발생한 부품을 Hewlett Packard Enterprise로 반환해야 하는지 여부를 CSR 교체 부품과 함께 배송된 자료에 지정합니다. 결함이 발생한 부품을 Hewlett Packard Enterprise로 반환해야 하는 경우에는 지정된 기간 내(통상 영업일 기준 5일)에 Hewlett Packard Enterprise로 반환해야 합니다. 이때 결함이 발생한 부품은 제공된 포장 재료에 넣어 관련 설명서와 함께 반환해야 합니다. 결함이 발생한 부품을 반환하지 않는 경우 Hewlett Packard Enterprise가 교체 부품에 대해 비용을 청구할 수 있습니다. 고객 셀프 수리의 경우, Hewlett Packard Enterprise는 모든 운송 및 부품 반환 비용을 부담하며 이용할 운송업체 및 택배 서비스를 결정합니다.

Hewlett Packard Enterprise CSR 프로그램에 대한 자세한 내용은 가까운 서비스 제공업체에 문의하십시오. 북미 지역의 프로그램에 대해서는 Hewlett Packard Enterprise CSR 웹사이트(<http://www.hpe.com/support/selfrepair>)를 참조하십시오.

## Remote support

Remote support is available with supported devices as part of your warranty or contractual support agreement. It provides intelligent event diagnosis, and automatic, secure submission of hardware event notifications to Hewlett Packard Enterprise, which will initiate a fast and accurate resolution based on your product's service level. Hewlett Packard Enterprise strongly recommends that you register your device for remote support.

For more information and device support details, go to the Insight Remote Support website (<http://www.hpe.com/info/insightremotesupport/docs>).

# Acronyms and abbreviations

**ABEND**

abnormal end

**ACU**

Array Configuration Utility

**AMP**

Advanced Memory Protection

**API**

application program interface

**ASHRAE**

American Society of Heating, Refrigerating and Air-Conditioning Engineers

**ASR**

Automatic Server Recovery

**CAS**

column address strobe

**CSA**

Canadian Standards Association

**CSR**

Customer Self Repair

**FSBBU**

Flex slot battery backup

**GPU**

graphics processing unit

**HBA**

host bus adapter

**HP SUM**

HP Software Update Manager

## HPE SSA

HPE Smart Storage Administrator

## IEC

International Electrotechnical Commission

## iLO

Integrated Lights-Out

## IML

Integrated Management Log

## ISO

International Organization for Standardization

## JSON

JavaScript Object Notation

## LFF

large form factor

## LRDIMM

load reduced dual in-line memory module

## NAND

Not AND

## NMI

nonmaskable interrupt

## NVRAM

nonvolatile memory

## PCIe

Peripheral Component Interconnect Express

## PDU

power distribution unit

## POST

Power-On Self Test

## RBSU

ROM-Based Setup Utility

## RDIMM

registered dual in-line memory module

## RDP

Rapid Deployment Pack

## REST

representational state transfer

## RoHS

Restriction of Hazardous Substances

## RSOC

relative state of charge

## SAS

serial attached SCSI

## SATA

serial ATA

## SD

Secure Digital

## SFF

small form factor

## SID

Systems Insight Display

## SIM

Systems Insight Manager

## SPP

Service Pack for ProLiant

## TMRA

recommended ambient operating temperature

## TPM

Trusted Platform Module

## UEFI

Unified Extensible Firmware Interface

**UID**

unit identification

**USB**

universal serial bus

**VC**

Virtual Connect

**VCA**

Version Control Agent

**VCRM**

Version Control Repository Manager

**VDC**

voltage direct-current

# Documentation feedback

Hewlett Packard Enterprise is committed to providing documentation that meets your needs. To help us improve the documentation, send any errors, suggestions, or comments to Documentation Feedback (<mailto:docsfeedback@hpe.com>). When submitting your feedback, include the document title, part number, edition, and publication date located on the front cover of the document. For online help content, include the product name, product version, help edition, and publication date located on the legal notices page.

# Index

## A

- AC power supply 189, 190, 191
- access panel 27, 28
- access panel, installing 28
- Accessing updates 193
- Advanced ECC memory 67, 68
- air baffle 32, 33
- airflow requirements 35, 36
- ASR (Automatic Server Recovery) 177
- authorized reseller 193
- Automatic Server Recovery (ASR) 177

## B

- battery 184
- battery backup module 129, 192
- battery backup, battery check button 15
- battery backup, LED 15
- battery check button 15
- battery warranty 185
- BIOS upgrade 169
- boot configurations 175
- boot options 41, 174, 175, 176
- BSMI notice 185
- button, battery check 15
- button, UID 10
- buttons 7, 9, 10

## C

- cable management arm 28
- cables 39, 135
- cabling 135, 139, 141, 146, 150, 151, 154, 155, 159, 164, 167
- cabling, controller 150
- Canadian notice 185
- Change Control 174, 182
- chassis components 11
- clearing NVRAM 18
- CMOS 17, 18
- components 7
- components, identification 7
- configuration of system 169
- configuration settings 175
- connectors 7
- contacting Hewlett Packard Enterprise 193
- controller 114, 116
- crash dump analysis 18
- CSR (customer self repair) 194
- customer self repair (CSR) 194

## D

- DC power supply 37
- default settings 67
- definitions 22
- device numbers 19
- diagnostic tools 169, 172, 174, 176, 177
- diagnostics utility 172
- DIMM identification 66
- DIMM installation guidelines 66
- DIMM population guidelines 68
- DIMM slot locations 19
- DIMMs 19, 66
- DIMMs, installing 69
- DIMMs, octal-rank 66
- DIMMs, quad-rank 66
- DIMMs, single- and dual-rank 66
- documentation feedback 206
- drive cage options 82, 86, 89, 94, 98
- drive LEDs 22
- drivers 180
- drives 22, 43

## E

- electrical grounding requirements 37
- embedded UEFI shell 176
- enabling the Trusted Platform Module 131, 134
- environmental requirements 35
- environmental specifications 187
- Erase Utility 169, 173
- error messages 183
- European Union notice 185
- expansion board options 112
- expansion boards 112, 113
- expansion slot blanks 112
- expansion slots 113
- Express Bay enablement option 46, 48, 146
- extend server from rack 26
- external USB functionality 178

## F

- fan cage 29
- fans 23, 30
- fans, installing 56
- features 7, 177
- Federal Communications Commission (FCC) notice 185
- firmware 179, 180
- firmware update 173, 179, 180

- firmware, updating 173, 179, 180
- flash ROM 180
- flex slot battery backup module, battery check button 15
- flex slot battery backup module, LED 15
- flexible boot control 175
- FlexibleLOM 110
- front panel buttons 9
- front panel components 7
- front panel LEDs 9
- FSBBU module 129, 192
- FSBBU module, installing 130
- FSBBU, battery check button 15
- FSBBU, LED 15
- full-length expansion board 32

## G

- grounding requirements 37

## H

- hard drive bays 7
- hard drive blanks 44
- hard drive cage 94, 98
- hard drive LEDs 22
- hard drives, determining status of 22
- hardware options installation 39, 43
- health driver 177
- health LEDs 9
- help resources 193
- Hewlett Packard Enterprise Technical Support 181, 193, 201
- host bus adapter 114, 150
- hot-plug fans 23, 30
- HP RESTful API 176
- HP Smart Update Manager overview 169, 174
- HPE 12G SAS Expander Card 118
- HPE Dual 8Gb microSD USB device 129
- HPE Flexible Smart Array Controller 114, 116
- HPE Insight Diagnostics 171, 172
- HPE Insight Online 171, 172
- HPE Insight Online direct connect 171
- HPE Insight Remote Support software 171, 181
- HPE Rapid Deployment Pack (RDP) 35, 204
- HPE RESTful API 176
- HPE SmartMemory 65
- HPE UEFI System Utilities 174

## I

- identifying the processor type 69
- iLO (Integrated Lights-Out) 169, 170, 171
- IML (Integrated Management Log) 169, 171
- Insight Diagnostics 172, 179
- installation services 35
- installation, server options 39, 43
- installing a drive 45
- installing a hot-plug SAS hard drive 44

- installing hardware 43
- installing PCI riser cage 31
- Installing the FSBBU module 130
- installing the server into the rack 39
- installing the Trusted Platform Module board 132
- Integrated Lights-Out (iLO) 170, 171
- Integrated Management Log (IML) 171
- Intelligent Provisioning 169, 172, 174
- internal USB connector 177

## J

- Japanese notice 185

## L

- labels 47
- LED, FSBBU module 15
- LED, health 11
- LEDs 13, 22
- LEDs, front panel 22
- LEDs, hard drive 22
- LEDs, power fault 11
- LEDs, power supply 11
- LEDs, SAS drive 22
- LEDs, SAS hard drive 22
- LEDs, troubleshooting 183
- limited warranty 185
- load protection guarantee 185
- location discovery services 107

## M

- M.2 SSD cabling 167
- M.2 SSD enablement board 126, 127
- M.2 SSD enablement option 126, 167
- M.2 SSD module 126
- mechanical specifications 187
- memory 63, 66, 68
- memory configurations 67, 68
- memory dump 18
- memory subsystem architecture 65, 66
- memory, configuration requirements 67, 68
- memory, configuring 67, 68
- memory, lockstep 69
- memory, mirrored 68, 69
- memory, online spare 68, 69
- memory-processor compatibility 63
- microSD card 129
- mirrored memory 68, 69

## N

- NMI functionality 18
- NMI switch 18
- NVMe SSD 23



## O

online spare memory 68, 69  
operating system crash 18, 177  
operating systems 181  
optical drive 7, 70  
optimum environment 35  
options installation 39, 43

## P

PCI expansion slot definitions 16  
PCI expansion slots 16  
PCI riser cage 30, 31, 73, 75, 77  
PCI riser cage, installing 31  
PCI riser cage, removing 30  
PDU (power distribution unit) 37  
phone numbers 193  
POST error messages 183  
power distribution unit (PDU) 37  
Power On button 26  
power requirements 36  
power supply 55, 192  
power supply LEDs 11, 14  
power supply specifications 189, 190, 192  
power up procedure 26  
powering down 26  
powering up 26  
power-on password 18  
preparation procedures 26  
problem diagnosis 183  
processor, installing 58

## Q

QuickSpecs 43, 66, 169

## R

rack installation 38  
rack warnings 38  
RAID configuration 177  
RBSU (ROM-Based Setup Utility) 169  
rear panel components 14  
rear panel LEDs 14  
rear panel, accessing 28  
recommended ambient operating temperature (TMRA) 36  
redundant ROM 178  
registering the server 42  
regulatory compliance identification numbers 183, 185  
regulatory compliance notices 185, 186  
regulatory information 185  
remote support 201  
remove PCI riser cage 30  
remove server from rack 27  
removing a hot-plug SAS hard drive 45  
removing the access panel 27

requirements, electrical grounding 37  
requirements, power 36  
requirements, site 36  
requirements, temperature 36  
RESTful API 170, 176  
retaining the recovery key/password 133  
ROM redundancy 178  
ROMPaq utility 169, 178

## S

safety considerations 38, 185  
SAS and SATA device numbers 19  
SAS drives 22  
scripted installation 173  
secure boot configuration 175  
serial number 176  
serial port 125  
series number 185  
server features and options 43  
Server mode 169  
server setup 35, 42, 179  
Service Pack for ProLiant 172, 173  
Service Packs 173  
shipping carton contents 38  
site requirements 36  
Smart Storage Battery 109  
space and airflow requirements 35  
specifications 187, 192  
specifications, environmental 187  
specifications, mechanical 187  
specifications, power 188, 189, 190, 191, 192  
specifications, server 187  
SPP 172, 173  
support 193  
supported operating systems 181  
switch, NMI 18  
switches 17, 18  
system battery 184  
system board components 17  
system components 7  
system configuration settings 178  
system maintenance switch 18  
system power LED 9  
Systems Insight Display 7, 11, 13, 105  
Systems Insight Display LED combinations 13  
Systems Insight Display LEDs 12, 13

## T

Taiwan battery recycling notice 185  
technical support 181, 193  
telco racks 27  
telephone numbers 193  
temperature requirements 36, 187  
TMRA (recommended ambient operating temperature) 36  
TPM (Trusted Platform Module) 131, 133, 134

troubleshooting 183

## **U**

UEFI 41

UEFI, boot mode 41

UEFI, server profile 176

UID button functionality 10

UID LED 18

uninterruptible power supply (UPS) 36

universal media bay 70, 164

updating the system ROM 178, 179, 180

UPS (uninterruptible power supply) 36

USB connector 7

USB devices 129

USB support 177

utilities 169, 174, 177

utilities, deployment 169, 173

## **V**

ventilation 35

Version Control 181

video connector 7

## **W**

warnings 38

warranty 185

website, Hewlett Packard Enterprise 193